



EEL 4914 Senior Design Project:

S.H.A.P.E.R

(Smart Home Automated Power Expense Regulator)

GROUP 18

Name: Juan Aleman

Name: Maria Alfonso

Name: Gregory Pierre

Name: Francine Vassell

Table of Contents

1.0	Executive Summary	1
2.0	Project Description	2
2.1	Project Motivation and Goals.....	2
2.2	Objectives.....	4
2.3	Project Specifications and Requirements.....	4
2.3.1	Hardware Requirements.....	5
2.3.1.1	Microcontroller.....	5
2.3.1.2	Occupancy Sensor.....	5
2.3.1.3	Ambient Light Sensor.....	6
2.3.1.4	Dimmable Light Bulb.....	6
2.3.1.5	Wireless Device.....	6
2.3.2	Software Requirements.....	7
3.0	Research related to Project Definition	7
3.1	Existing Similar Projects and Products.....	7
3.1.1	Homeseer.....	7
3.1.2	Control4.....	8
3.1.3	Creston.....	9
3.1.4	DKC Automation.....	10
3.2	Relevant Technologies.....	11
3.2.1	Power Monitoring.....	11
3.2.1.1	Estimated Appliance Operating Cost List According to Duke Energy.....	11
3.2.1.2	Analysis of data.....	15
3.2.1.3	Power Monitoring Options.....	15
3.2.2	Wireless Networks and Communication.....	16
3.2.2.1	Wi-Fi.....	17
3.2.2.2	Bluetooth.....	17
3.2.2.3	Near Field Communication (NFC).....	18
3.2.3	Electronics Power Supply.....	19
3.2.3.1	Lead Acid Battery.....	19
3.2.3.2	PowerSwitch Tail.....	19
3.2.3.3	Relays.....	20
3.2.4	Occupancy and Ambient Light Sensors.....	21
3.2.4.1	Occupancy Sensor.....	21
3.2.4.1.1	Ultrasonic.....	22
3.2.4.1.2	Passive Infrared (PIR).....	22
3.2.4.1.3	Software Using Surveillance Cameras.....	23
3.2.4.1.4	Microwave.....	24
3.2.4.2	Ambient Light Sensor.....	24

	3.2.4.2.1 Photo Resistor	25
	3.2.4.2.2 Photo Diode	25
	3.2.4.2.3 Photo Transistor	26
3.2.5	Mobile Operating System Compatibility	26
	3.2.5.1 Mac OS	27
	3.2.5.2 iOS	27
	3.2.5.3 Android OS	28
	3.2.5.4 Microsoft Windows OS	29
	3.2.5.5 Windows Phone OS	31
3.2.6	Microcontroller	32
	3.2.6.1 Microcontroller Families	33
3.2.7	LCD Screen	34
3.2.8	Power Inverter	36
3.2.9	Light Bulb Dimmer	37
3.3	Strategic Components	39
3.4	Possible Architectures and Related Diagrams	41
	3.4.1 Block Diagrams	41
	3.4.1.1 System Input / Output Workflow	41
	3.4.1.2 Occupancy and Dimmable Sensor Process	42
	3.4.1.3 Application Software Control Process	43
	3.4.1.4 Energy Monitoring System Process	44
	3.4.2 Devices / Elements Interface Sketch	45
4.0	Related Standards and Constraints	46
4.1	Design impact of relevant standards	46
	4.1.1 Table of Powering Monitoring and Wireless Network Communication Standards	47
	4.1.2 Table of Occupancy Sensors and Ambient Light Sensor Standards	47
	4.1.3 Table of Operating System Compatibility Standards	48
	4.1.4 Table of Electronics Power Supply, Microcontroller, LCD Screen, Power Inverter and Light Bulb Dimmer Standards	49
4.2	Realistic Design Constraints	50
	4.2.1 Economic and Time constraints	50
	4.2.2 Environmental, Social, and Political constraints	51
	4.2.3 Ethical, Health, and Safety constraints	52
	4.2.4 Manufacturability and Sustainability constraints	53
5.0	Project Design Details	54
5.1	Initial Hardware Design Architectures and Related Diagrams	54
5.2	Hardware Design	56
	5.2.1 Central Hub	57
	5.2.1.1 Microcontroller	57
	5.2.1.2 PIR Motion Sensor with Embedded Microcontroller	67
	5.2.1.3 Bluetooth Component	72
	5.2.1.4 Light Dimmer Circuit	73
	5.2.2 Power Monitoring Nodes	75

	5.2.2.1 Microcontroller and Bluetooth Component	75
	5.2.2.2 Power Monitoring IC	79
5.3	Software Design	81
	5.3.1 Microcontroller	82
	5.3.2 Dimmable Lighting System	83
	5.3.3 Thermostat Capability	86
	5.3.4 LCD interface	87
	5.3.5 Bluetooth Remote and Sensor	87
5.4	Additional Design Components	88
	5.4.1 Dimmable Light Bulbs	89
	5.4.2 Ambient Light Sensors	90
	5.4.3 AC Thermostat	91
	5.4.4 LCD Screen	94
	5.4.5 Relay	94
	5.4.6 Lead Battery	94
	5.4.7 Power Inverter	95
5.5	Mobile Operating System Design	96
	5.5.1 Android Selection	96
	5.5.2 Android Application Designing Software	98
	5.5.3 Android Application Design Logic	98
	5.5.3.1 Home Screen Design Logic	98
	5.5.3.2 Power Monitoring Design Logic	99
	5.5.3.3 Lighting Control System Design Logic	101
	5.5.3.4 Cooling Control System Design Logic	102
6.0	Project Prototype Construction and Coding	104
6.1	Hardware Prototyping	104
	6.1.1 Power Supply Components	104
	6.1.2 Central Hub	104
	6.1.2.1 PCB Vendor and Assembly	104
	6.1.2.2 Sensors	105
	6.1.2.3 Dimmable Lightning System and Thermostat	105
	6.1.3 Power Monitoring Nodes	105
	6.1.3.1 Power Monitoring Circuit	105
	6.1.3.2 LCD Display	106
6.2	Software Prototyping	106
	6.2.1 Hardware	106
6.3	Android Application Prototyping	107
	6.3.1 Android Application Home Screen Prototype	107
	6.3.2 Android Application Lighting Control Prototype	108
	6.3.3 Android Application Cooling System Prototype	109
	6.3.4 Android Application Power Monitoring Prototype	110
7.0	Project Prototype Testing	112
7.1	Hardware Testing Environment	112
7.2	Hardware Specific	113
	7.2.1 Arduino Board	113

7.2.2	Occupancy Motion Sensor	113
7.2.3	Ambient Light Sensor	113
7.2.4	LCD Display	114
7.2.5	Power Monitor IC	114
7.3	Software Specific	114
7.3.1	Hardware Related Software	114
	7.3.1.1 Light System	114
	7.3.1.2 Thermostat	115
	7.3.1.3 Bluetooth Technology Interaction	115
7.4	Android Application	115
7.4.1	Android Application Home Screen Testing	116
7.4.2	Android Application Lighting Control Testing	117
7.4.3	Android Application Cooling Control Testing	118
7.4.4	Android Application Power Monitoring Testing	118
8.0	Administrative Content	121
8.1	Finances and Budget	121
8.2	Division of Work	123
	8.2.1 Roles and Responsibilities	123
	8.2.2 Division of Design Process	124
8.3	Milestones	126
8.4	Sponsors	130
8.5	Mentors	131
9.0	Project Summary & Conclusion	131
10.0	Appendices	I
10.1	Copyright Permissions	I
	10.1.1 Permission from TI	I
	10.1.2 Permission from Atmel	I
	10.1.3 Permission from PowerSwitch Tail	I
	10.1.4 Permission from Professor John Loomis	II
10.2	References	II

List of Figures

Figure No.	Description	Page No.
Figure 1	Global Household Electricity Consumption	3
Figure 2	PowerSwitch Tail II circuit diagram	20
Figure 3	Diagram of a Simple LCD Module	36
Figure 4	Diagram for a Simple Power Inverter	37
Figure 5	Diagram for a basic SCR Dimmer	39
Figure 6	System Input / Output Workflow	42
Figure 7	Occupancy & Ambient Light Sensor Process.	43
Figure 8	Application Software Control Process	44
Figure 9	Energy Monitoring System Process	45
Figure 10	Device / Elements Interface Sketch	46
Figure 11	Diagram of Initial Hardware Diagram	56
Figure 12	Functional Block Diagram for Microcontroller MSP430F6638	60
Figure 13	Pin Designation for Microcontroller MSP430F6638IPZR	61
Figure 14	Microcontroller designed to be used for S.H.A.P.E.R.	66
Figure 15	MSP430F2013 Motion Detection System	68
Figure 16	MSP430-PIR Sensor Block Diagram	70
Figure 17	MSP430-PIR Sensor Schematic	71
Figure 18	Functional Block Diagram for Microcontroller used in MSP430-PIR board, the MSP430F2013	72
Figure 19	Functional Block Diagram of the Dual-Mode Bluetooth CC2564BRVMT	73
Figure 20	Simple Light Dimmer Circuit	74
Figure 21	Typical LM3445 LES Driver Application Circuit	75
Figure 22	Block Diagram of the 2.4-GHz Bluetooth Low Energy and Proprietary SoC CC2541F256RHAR	78
Figure 23	Register Block Diagram for INA231	81
Figure 24	Motion Detection Software Flowchart	84
Figure 25	Dimmable Light System Characteristics Flowchart	85
Figure 26	Thermostat Compatibility Flowchart	86
Figure 27	Bluetooth Remote and Sensor Flowchart	88
Figure 28	Basic AC Thermostat Board	92
Figure 29	Pinout for MCU	93
Figure 30	RS-485 Circuit	93
Figure 31	Basic LCD Screen Interface	94
Figure 32	Home Screen Design Logic Flowchart	99
Figure 33	Power Monitoring Design Logic Flowchart	100
Figure 34	Lighting Control System Design Logic Flowchart	101
Figure 35	Cooling Control System Design Logic Flowchart	103
Figure 36	Home Screen Prototype	108

Figure 37	Lighting Control Prototype	109
Figure 38	Cooling System Prototype	110
Figure 39	Power Monitoring Prototype	111
Figure 40	Example Power Displayed Line Graph	112
Figure 41	Example Power Displayed Pie Graph	112
Figure 42	Cost Distribution Pie Graph	123
Figure 43	Design Process Area Chart	126

List of Tables

Table No.	Description	Page No.
Table 1.1	Duke Energy's Appliance Operating Cost List	11
Table 1.2	Duke Energy's Appliance Operating Cost List (Cont)	12
Table 1.3	Duke Energy's Appliance Operating Cost List (Cont)	13
Table 1.4	Duke Energy's Appliance Operating Cost List (Cont)	14
Table 1.5	Duke Energy's Appliance Operating Cost List (Cont)	15
Table 2	Power Monitoring and Wireless Network Communication Standards	47
Table 3	Occupancy Sensors and Ambient Light Sensor Standards	48
Table 4	Operating System Compatibility	49
Table 5	Electronics Power Supply, Microcontroller, LCD Screen, Power Inverter and Light Bulb Dimmer Standards	50
Table 6	Desired Characteristics for the Microcontroller used in this Project	58
Table 7	Comparison between MSP430 Family Series 5 and 6 Characteristics	59
Table 8.1	Pinout Description of MSP430F6638 obtained from TI Datasheet	62
Table 8.2	Pinout Description (Cont.) of MSP430F6638 obtained from TI Datasheet	63
Table 8.3	Pinout Description (Cont.) of MSP430F6638 obtained from TI Datasheet	64
Table 8.4	Pinout Description (Cont.) of MSP430F6638 obtained from TI Datasheet	65
Table 9	Desired Characteristics for the PIR Motion Sensor Board used in this Project	67
Table 10	Comparison of PIR Motion Sensor Boards Considered for this Project	68
Table 11	Desired Characteristics for the Bluetooth Component used in this Project	76

Table 12	Comparison of Microcontroller with Integrated Bluetooth Component Considered for this Project	76
Table 13	Comparison of Current/Power Monitor Considered for this Project	80
Table 14	Dimmable Light System Characteristics	85
Table 15	Desired Characteristics for the Dimmable Light Bulb used in this Project	89
Table 16	Comparison of PIR LEDs Dimmable Light Bulbs Considered for this Project	90
Table 17	Desired Characteristics for Ambient Light Sensor used in this Project	91
Table 18	Comparison of Ambient Light Sensors Considered for this Project	91
Table 19	Desired Characteristics for the Modified Sine Wave Power Inverter	95
Table 20	Comparison of Modified Sine Wave Power Inverter	95
Table 21	Android Vs iOS Comparison	97
Table 22	Home Screen Test Plan	116
Table 23	Lighting Control Test Plan	117
Table 24	Cooling Control Test Plan	118
Table 25	Power Monitoring Primary Testing Test Plan	119
Table 26	Power Monitoring Secondary Testing Test Plan	120
Table 27	Estimated Costs per Part	122
Table 28	First Quarter Milestones	127
Table 29	Second Quarter Milestones	128
Table 30	Third Quarter Milestones	129
Table 31	Fourth Quarter Milestones	130

1.0 Executive Summary

Home automation is a rising market with plenty of opportunity for growth. Consumers will want products that make their lives easier and more efficient. This is where the S.H.A.P.E.R (Smart Home Automated Power Expense Regulator) comes in. With the S.H.A.P.E.R, we will be able to mold the consumption of energy into its optimal valuable. S.H.A.P.E.R will make life easier by automating the lighting within ones residence to reduce wasteful energy consumption. The temperature of a home's thermostat will also be automated to reduce the wastefulness of the highest energy consuming appliance. The energy consumption of the rest of the items around the home will be reported to the users and suggested energy use plan to maximize efficiency.

In this report, we will research all the aspects of this assignment to make it a competently assembled system. We take a look at the current existing projects and products that may inspire us in our planning. We will need to know what technologies we will need to use to implement our final vision. This is done by reviewing the relevant technologies that are currently available. The strategic components of our system will be explained in full and their importance. Possible architectures and related diagrams will be shown to better relate our vision and our state of mind. There are many considerations that must be taken when designing our system. We take a look at the design impact of relevant standards and how they affect the system we plan to create. Design constraints are also taken into account and how will we accommodate for them. Creating a system that will help reduce power cost will have a significant social and economic impact.

We make optimal design choices for the hardware and software components of our system. We want our system to save our end users money, freeing them up from monetary burdens. Our systems uses parts that they themselves use a low amount of power. We ensure that the components chosen are fully compatible with each other and function at the optimal desired specification when doing so. Applying the information we learned throughout the length of our studies in electrical and computer components in the University of Central Florida, we create fully realizable schematics of the components that will bring the smart home automated power expense regulator to life.

To properly ensure our final product will meet the objectives we plan to achieve, we emphasize the use of prototypes. The prototypes will give us a system to test and improve upon. We will make sure our prototypes are properly helping to regulate the expense of power in the household. Our prototypes will be built in separate sections and then the separate section will later be attached together. The hands on experience we acquired in laboratory portions of our courses at this university will play a crucial part in how we go about developing our prototype. The prototype will be built to ensure that it can control the intensity of the bulbs in the system and alter the thermostat in a way that power will not be wasted when the user is not present or when there is no need to expel the maximum amount of power.

The testing of our prototype will verify that our project is meeting the goals we set forth. Multiple cases and different trials with different variables will be used to thoroughly test the completeness of our project. If parts of the project are not meeting our requirements, as verified by the testing, changes will be made to the prototype and the updated prototype will be retested once again.

This project will have to be properly managed in order to function and be created properly. The administrative content section of this report will document the steps taken to ensure that our project is completed thoroughly and completely. It will break down the division of labor and the design process among our members. It will also explore the financial and time considerations we took into account and how we met them. And finally, the role our mentors and sponsors had in the creation of our project will be explained and the great appreciation we have towards them will be understood.

In our project report, we then summarize and conclude all we have accomplished in the process of designing the smart home automated power expense regulator. We are proud to be bringing such a fun and positive idea to life. What we have learned at the University of Central Florida is to look for the good in the hearts of individuals. We not only aim to create a product that helps others, but also inspire others to do the same.

2.0 Project Description

In our project description, we will give a detailed description of what our project will consist of. In order to fully understand the full nature of our project, we must explore why it is we came to the decision to bring this project into existence. To begin, we will first give an explanation of our projects motivation and its goals. Motivation and goals will explain our inspiration and what dreams we aspire to achieve overall. To further grasp the nature of our project, one must fully explore our projects objectives. Having clear objectives will help guide us in the appropriate direction. As long as we focus on the objectives we want to achieve, the creation of our project will progress unhindered. We must finally look at the specifications and requirements for this project.

2.1 Project Motivation and Goals

We live in a technology-driven era with smart phones, smart cars, smart TVs and even smart washing machines, where technology works for us and makes our lives easier. As engineers we strive to make things more efficient, which creates the motivation for us to implement processes in people's houses that are automated and more productive by saving energy. This project was chosen because, not only does it motivate us, but also it is something users would love to have due to the good feedback received by smart-components consumers. We, as engineers, want to fulfill our obligation to the community and create something that can really impact their lives and make a difference.

A large amount of electricity is used in households worldwide. Currently, the United States is the second highest in energy consumption after Canada. If we could get the amount of power used in households down, we would save a great deal of resources. In addition to saving a large amount of resources, we will potentially be improving the state of the environment that we live in. Below is Figure 1 showing the division of energy consumption among the top 10 countries who consume energy. [1]

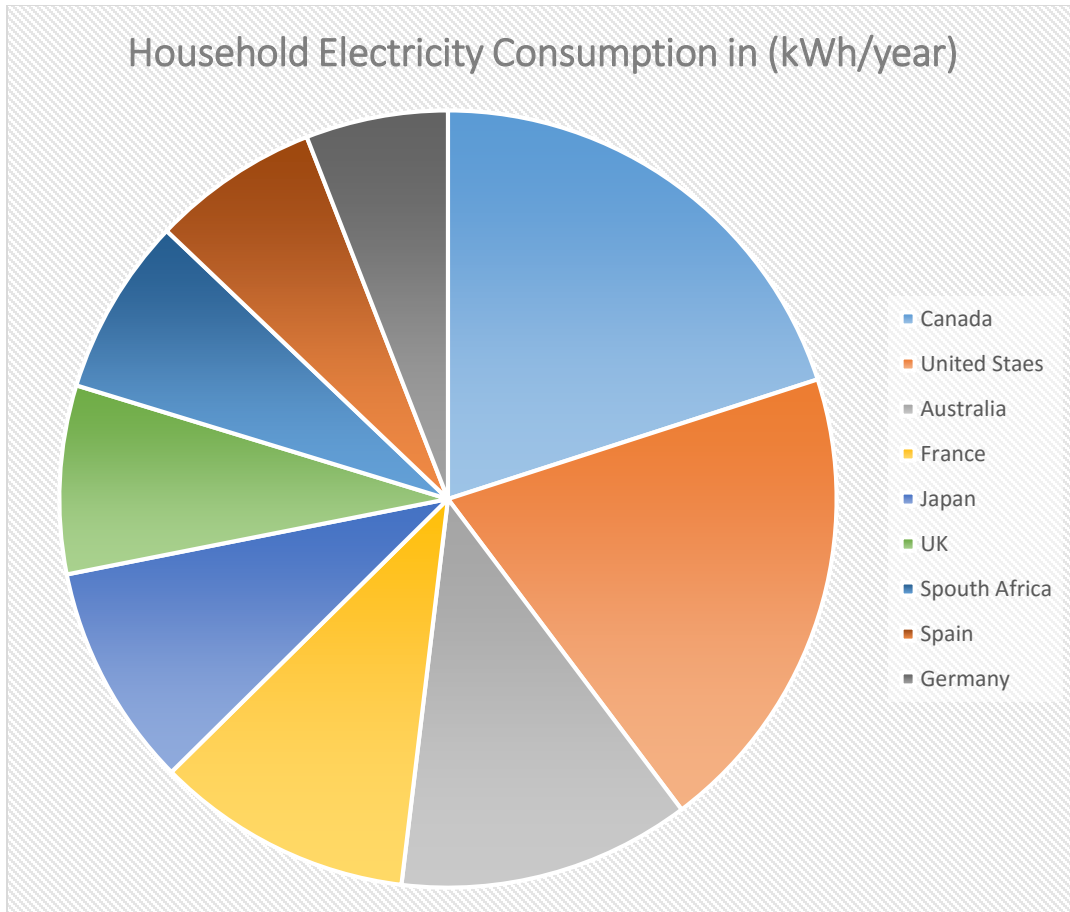

Figure 1: Global Household Electricity Consumption
(Created with information from [1])

A member of our group came from a country where electricity for her home was not always readily available. Upon coming into this country, she saw a land where opportunity was readily available. Her appreciation for the many resources available to us, that some take for granted, spawned the embers of what later came to be an idea to bring efficiency and stability to energy consumption of everyone around the world. The original focus of our system was going to be regulating a series of dimmable lights and would alter their intensity depending on the amount of preexisting light and whether a room was occupied. This aspect of the system would appeal to the user's sense of easement. Having more tasks automated for them can make a user's job and life easier.

As engineers, we are constantly reaching further and testing the limits of what we can do and what we can overcome. We felt it was important to extend our reach to the air conditioning system. The air conditioning system uses much of the power in a household. Control over this would greatly impact the user's energy costs and power consumption. We decided to have tie the settings of the thermostat to occupancy sensors we used for the dimmable lights. The thermostat temperature would be regulated depending on whether or not someone was present in a room to certain preset specifications. With this, we would now have, both a system that would simplify the user's daily life and a system that would lessen the user's expenses.

Our ambitions took us even further. We felt that we could move to other appliances and power consuming items around the home. Our smart system would automatically measure the amount of power that was consumed and report that to the user. Our system would also give suggestions and recommendations to help shape the user's choices. With this, the Smart Home Automated Power Expense Regulator was born.

2.2 Objectives

Applying our knowledge that we have gained in electrical and computer engineering, we can intelligently create a system that achieves the goals and objectives we plan to set forth. To begin, the automated system is innovative because it will turn on or off the bulbs in the house and achieve a preferred preset AC temperature based on the fact that someone is inside the room or not using an occupancy sensor. In addition, using an ambient light detector, the system will be able to identify if there is daylight present or not in the area. In the case there is outside light present, the intensity of the bulb will adapt reaching a minimum preset percentage. If there is little outside light, the intensity of the bulb will change up to a maximum preset percentage. In the case that the user leaves the room, the AC will return to its original temperature and the lights will turn off making this product energy efficient as well. We aim to make the lives of our users less burdensome.

Our system will monitor the wattage per hour used for each appliance and communicate that information back to the user's device. The user of the system will be able to get an accurate portrayal of what his or her energy costs will be if they continue to consume energy at that rate. We will be monitoring the usage of cooling/heating system, water heater, lighting system, clothes dryer, refrigerator/freezers, stove and more. Using machine learning, we will be able to predict and analyze the user's activity. We will be able to give the user suggestions that would better shape their energy consumption. The user will see an estimate of what how much energy he will consume and what his estimated final bill will be. With this the user will be able to make informed decisions of the choices they would have to make.

In addition, the user can choose to interact with the system directly via a smartphone/tablet application directly or through voice commands to control the lighting and the AC system in the house. The user will control the system and all of its functions with the device. The device will be fully capable of managing and changing the settings to fit the user's needs and specific preferences. Reports and suggestions generated from the system will viewable from the user's device. There will be wireless communication technology that facilitates these features to exist. The device will be able to store information of the system's usage for as long as the user may require it to.

2.3 Project Specifications and Requirements

The specifications of the requirements for the different components of our project is a very important aspect to note. Our specifications and requirements will guide us toward what our end goals will be. We will design around requirements that are abstract, verifiable, unambiguous, and are traceable. We have identified our requirements through research, the observation process, brainstorming sessions, and competitive benchmarking. During the conception of our requirements, we have ensured that our requirements are normalized, meaning that we avoid any

overlap and redundancy among requirements. Great detail has been given to make sure requirements are consistent and do not go against their own purpose. Our requirements are in the form of baseline requirements and modifiable if other needs and constraints are discovered in the future.

It is crucial for us to recognize all the potential needs our users will need. We will try to address all the possible variations of desires that can be fulfilled in our project. To do this, we must avoid under specificity. A complete set requirements is developed in order to achieve maximum satisfaction. This will greatly improve our design, however we have to ensure that in trying to solve one problem we don't create another. We don't want to fall in the trap of over specificity. We will have our requirements bounded, meaning the scope of what they will affect will be identified, but we will ensure that there isn't more bonds than need be. Doing this will help ease the process of confirming that the requirements can be validated.

2.3.1 Hardware Requirements

The physical aspects of our project must be manageable. It cannot be too cumbersome or take up too much room. In our project, we will use wireless communication when feasible to avoid the burden of lengthy wired connections and used necessary. A great deal of concern must go into the requirements we will set forth for the hardware component of this project. There are different pieces of hardware we can use, but we have to make sure the hardware choices we pick can help us to achieve our end goal. The main hardware components we will be using will be the microcontroller, occupancy sensor, dimmable light bulb, and wireless device.

2.3.1.1 Microcontroller

We will need a microcontroller that will be the brain of our operation. It should be able to control every aspect of our system. The reach of the microcontroller will cover all the subsequent parts of our system. The function of the sensors and the appliances of our system must be controlled by the microcontroller. It will also need to store information that is created for future use. This will require it to have ample memory space to store data.

- Must have enough storage to be able to store the vast amounts of information that is going to be generated.
- Must have enough computational speed to accurately manage the many devices that may be connected to it.
- Must be compatible with various means of wireless communication (i.e. Wi-Fi, Bluetooth).
- Must include Watchdog timer.
- Must feature ultra-low to low power consumption.
- Must include several serial interfaces, so it can support many peripherals.

2.3.1.2 Occupancy Sensor

Our system project will need to take into account the presence of someone in the room. This is crucial to some of the major aspects of our overall goal. When an individual is not present in a room, there will be no need to waste unnecessary power. An individual entering a specified area of our system will trigger certain conditions we have in our system. The lighting and the cooling

system will be dependent from the input of the occupancy sensor. The occupancy sensor will need to have a way to communicate with the rest of the system. It will also need to have an efficient way of processing information.

- Must be able to recognize the presence of an individual in an area reaching as large as 200 square feet.
- Must itself be a lower power consuming device consuming no more than 5 watts per hour.
- Must be low cost, \$20.00 per sensor.
- Must use and/or be compatible with wireless communication technologies.
- Must include a microcontroller.

2.3.1.3 Ambient Light Sensor

We will be needing to utilize an ambient light sensor to detect the time of day it is. Depending on what time of day, we will regulate the amount of power that is being consumed. Determining the amount of ambient light is already present in our environment will allow us to choose accordingly how much light we need to apply.

- It must be able properly detect the amount of light currently being let into our environment from outside.
- Must be able to properly respond to visual light.
- Must be able to reject ultraviolet (UV) or infrared light (IR).
- Must feature low power consumption.

2.3.1.4 Dimmable Light Bulb

The dimmable light bulbs are some of the very important parts of this project. They will showcase the proper functionality of the system. They will need to be adjustable in relations to the input from the occupancy sensor and ambient light sensor. These will be the best way to showcase the effectiveness of our system. They will need to be able to produce and optimal amount of lumens in an area. The price of the dimmable light bulb should also be low or produce favorable savings over a period of time. Another fact to look into is that dimmable lights vary in the range they can dim. We would want a bulb that would give us a wide range of level it could be dimmed at.

- Must consume 15 watts per hour or less.
- Must feature a lifespan of over 10,000 hours in order to avoid having to re-purchase a new one in the future.
- Must properly illuminate a room up to the size of 200 square feet.
- Must feature a dimmable range of 100% through, at least, 10%.

2.3.1.5 Wireless Device

There are a lot of parts in our project. We will need a device that will be able to manage all of the different parts to our system. The user of the system should be able to interact with the system and manipulate the settings of the system to their liking. The analytical reports will be delivered to the user to show how much power was consumed and give suggestions on how to better power use. Some of the most common examples for this device are an apple or android phone, but can also be another device. Software with the ability to control the system we are creating will be placed on

the device in order to allow the device to manage the system. The device will also need to have enough memory space to store data we will be receiving from the created system.

- Must support wireless connectivity.
- Must be able to hold at least 100 MB of space.
- Must include a proper interactive graphic user interface.
- Must contain proper security maintain secure data.
- Must be compatible with the selected microcontroller.
- Must feature low energy consumption.

2.3.2 Software Requirements

Just like in our hardware requirements, a great deal of concern must go into the requirements we will set forth for our software component of this project. The software must be fully able to manage the microcontroller and allow it to perform the tasks that are needed. The software must be designed in such a way that it takes into account all the possible scenarios we may have for our system and addresses them accordingly. Software that is fully understandable and is properly commented will be assist us in case any future changes need to be made and for others reading the software to understand its purpose.

- Software controlling the hardware components, Implemented in basic assembly language.
- Software for the application overseeing the different components of the project, should be coded in Java.
- Use of standard libraries

3.0 Research Related to Project Definition

In order for S.H.A.P.E.R. to come to life a large amount of brainstorming during our weekly meetings took place. Once we all agreed on the key components for the system every team member started researching about the best fit for our project. Hence, our search was broken down into existing similar projects and products from different competitors, the different relevant technologies that can be implemented, the strategic components we can benefit from and the possible architectures and related diagrams to be used for easiness of design.

3.1 Existing Similar Projects and Products

As it was mentioned before in order for us to comprehend what kind of technology we were dealing with and what our design was going to be all about, a studied in our competitors in the business took place. This way we can grab the best of their project and use it as a foundation for ours in addition to those new technologies that have not been implemented yet that can be taken advantage of to make S.H.A.P.E.R. more desirable in the market.

3.1.1 Homeseer

HomeSeer is a home automation system that started its appearance in the market since 1999. This system allows the user to control lighting, cameras, sensors, climate, security, energy, garage

doors, audio/video, water, door locks, power, and irrigation, among other things. The reason why it is chosen as the first option under this category is because of the fact that it scored first place and received a Gold Award in the 2015 Home Automation System Review by toptenreviews.com from Purch, a company that has as a goal provide customers with important information about a particular product. Moreover it has voice control capabilities with an integrated software or with your smart device. These software allow the user to create “automation events” that runs itself through a user interface and using voice commands. Also, allows the integration of a camera on a local network which allows the system to control it remotely. All the latest generations of Homeseer models come with regular Windows OS, Windows mobile OS, Apple IOS and Google Android OS compatibility. The Application allows the user to Dim the lights in the house, lock and unlock the doors remotely, control the AC temperature and it has a list of past events built-in. Also, it has an option that lets the user control, browse and play their music by connecting syncing their iTunes account with the application by using their mobile device. Moreover, it shows power amount of Watts used periodically but it does not provide any suggestions or tips for the customer to improve their habits.

Their base model (the HomeTroller Zee S2) comes with a price tag of \$199.95 offers support for everything that was previously mention but it excludes compatibility with security systems, Audio / Video Equipment, Irrigation systems, Pool / SPA and Home Phone System. Everything except for the last item is available for additional cost. The Operating system is Linux and for the key specifications it has a 900 MHz Quad-core processor with 1GB of RAM, 8 GB SD for primary storage 4 USB ports, HDMI video port and 5 Watts of power consumption. The top of the line device is the HomeTroller S6 PRO for \$1,199.95, which provides everything stated before included except for the Pool / SPA option which can be added for an additional cost. This controller runs Windows 7 embedded with a 1.80 GHz Dual-core Celeron processor, 4 GB of RAM(for the newer released version of the PRO model), 32 GB SSD for primary storage, 6 USB ports, HDMI and DVI video ports and 14 Watts of power consumption.

As it can be seen, HomeSeer is one of the best home automation systems in the market, it offers support for pretty much all the key things that you can find in a house and allows the user to integrate even more options (for an extra price). However, their base model is limited and the top of the line one is certainly expensive considering that you still have to buy components such as the dimmable and climate system, environmental sensors, video camera, etc. Additionally, even though the system lets the user know their power consumption periodically it doesn't really state any suggestions to improve the current habits and save more money. This can be a great opportunity to integrate this capability to S.H.A.P.E.R. to offer similar compatibility with the lighting and climate system using an user-friendly software with voice recognition integrated that learns the different habits the user applies to their daily commute and then provides a list of tips for them to get the most value out of the product.

3.1.2 Control4

Control4 is another experienced company that designs home automated system and also sells accessories that go along with it. Control4 was founded in 2003 and as their mission they strive to deliver an elegant and more affordable way to control and automate lighting, music, video, security and energy all over the house. Control4 scored second place in the 2015 Home Automation System

Review by toptenreviews.com mentioned above in the HomeSeer section. Control4 offers compatibility with a large number of third-party consumer electronics. They offer a broad variety of platform products such as controllers, in-wall touch screens, tabletop touch screens, apps, among other accessories.

They have two kind of controllers, the first one is the HC-250 which allows control for single-room control systems, universal remote replacements or as a way to deliver on-screen control to all the television in larger residential or small businesses. It runs the Control4® operating system which allows the user to not only control their house but also listen to music and play videos. The Control4 App enable home control from Apple, Android and Windows devices. It comes with a 1GHz processor, an analog audio input and output, one HDMI, Ethernet and USB port respectively for a price of \$750. In addition, the HC-800 model is created to run more demanding control systems. It offers great performance when it comes to connecting and controlling all of the options mentioned above in a typical home or small business system while playing audio and video file just like the HC-250. It can be used from most Apple, Android and Windows devices plus using one of their touch screens on-screen navigators or remote controls. It has a 1.8GHz processor integrated to maximize the power of their own operating system, I/O to control devices through IR, RS-232 serial, ZigBee, contacts and relays. It also comes with 4 audio outputs, external antennas for wireless performance plus an HDMI, Ethernet and USB port respectively with a price tag of \$1,500.

The Control4 app seems to be very interactive since multiple devices can be connected, such as a DVR, TV and even video game consoles. It allows the user to control the lighting, the locks for the house, the thermostat, etc. Similarly to HomeSeer there are no suggestion or tips for the user to improve their power consumption habits. Compared to HomeSeer it seems that Control4 offers the user a more elegant experience with the comfort of controlling multiple devices using the app, an on-screen navigator or the remote control that comes with the system. Also, Control4 is compatible with a vast amount of third-party companies, has large amount of accessories to choose from and overall it seems to be more user-friendly. Nevertheless, this all-in-one design comes with a very high price tag and limited amount of options from the user to choose from and it lacks of a built-in voice recognition option, which is only available using third party apps or devices such as VoicePod. Additionally, it is still missing the capability of letting the user know how power is being managed, learn the habits and provide tips to improve them.

3.1.3 Creston

Creston is Electronics is a global technology company founded in 1968. They have a broad experience in many areas outside of home automation, reason why they manufacture a big part of the accessories and add ups that can be added to the system. As expected, the reason why Creston is being considered as good competitor to compare is because it obtained third place in the 2015 Home Automation System Review by toptenreviews.com. Something worth mentioning is the way the system is presented in the Creston's home page. It provides a good introduction to the product by keeping the customer interested. There are two options, home and work, depending on where you hover you mouse pointer a simple but concise video shows the different ways Creston can be used in these two different environments. This convenience is something worth looking at when

presenting S.H.A.P.E.R. to a possible consumer. However, it was challenging to find specific information about their home automation system itself and pricing options.

Creston has two main systems available for the customer. The base system is called the PYNG-HUB which interacts from the Creston Pyng® App or other control accessories. It can be used to control audio, lighting, shades, thermostats, door locks, security and power management (for an additional price). Unfortunately, Creston doesn't provide information about what the processor speed and RAM memory are for this device, but it has Ethernet and wireless communications, a micro-B USB port and a slot for memory card all for \$599. In addition, Creston offers a second model called the 3-Series® Room Media Controller. It can be used for all of the applications mentioned above for the PYNG-HUB with an ultra- compact form factor with an IP-based 3-Series platform. It is design to deliver great performance to manage all systems in a building; which makes it great for commercial facilities. It has 256MB of RAM and 4 GB of Flash Memory, support for external USB flash memory and mass storage devices with iphone, ipad and Android support. Also, it has a RS-232 port with hardware and software handshaking, two IR/Serial, two relay, two digital input ports and a USB On-The-Go port. It is C#, symbol based and drag-and-drop programming environments; all with a price tag of \$1,000.

As it can be seen, Creston offers a broad variety of products for their control systems, reason why they don't have the all-in-one design that Control4 provides but the control system is less expensive for both models. If comparing with HomeSeer, it can be noticed that the price is near the same range but it is not as user-friendly since HomeSeer comes with the Win7 Embedded operating system and from the little information Creston provides about the technical specifications; we can conclude that HomeSeer offers a more powerful alternative for the user. Creston has been in the market for quite some time, reason why they have a more broad scope other than just home automation systems. Which explains why their home automation system is good but it scored third place in the toptenreviews.com home automation system comparison. Finally, we see again that it lacks of the whole learning-from-the-user experience, which is surprising considering the fact that we're talking about possibly the best three home automation systems in the market, this is a great opportunity for S.H.A.P.E.R. to make a difference by suggesting simple tips to develop better habits, save money and be more eco-friendly.

3.1.4 DKC Automation

Droid KC is a small store in Kansas that created a home automated system called DKC Automation. Even though this is not a popular system overall such as HomeSeer, Cronrol4 and Creston it is worth mentioning that they have a system that allows the user to fully control their house using an Android device and its voice recognition software. The user only has to say "Ok Google" followed by the command and can ask to turn on, off or simply dim the lights. Additionally, the user can program a particular scenario where the lights get dimmed and then the TV, along with the DVR turns on so the user can not only watch the shows he/she desires but also, have the ability to control remotely the TV using only voice commands. After doing some researched we found that it is much simpler to implement Google's voice recognition software using an android device that connects to S.H.A.P.E.R. rather than creating and programming a voice recognition device from scratch.

3.2 Relevant Technologies

After researching about the existing competition in the market we understand what route needs to be taken in order for S.H.A.P.E.R to succeed. In order to make it happen, the appropriate components that are going to be used for our design have to be considered. Our research was divided into power monitoring, wireless networks and communication, electronics power supply, occupancy and ambient light sensors, and operating system compatibility.

3.2.1 Power Monitoring

Monitoring power is one of the key features of this project. Therefore, it is important for S.H.A.P.E.R. to study how this is going to be achieved. First, a set of four tables with estimated appliance operating cost input from Duke Energy is incorporated, then a description of how the data is going to be analyzed in the system can be found and finally different options to power S.H.A.P.E.R. are incorporated.

3.2.1.1 Estimated Appliance Operating Cost List According to Duke

The estimated appliance operating cost list developed by Duke Energy was divided into four different tables as stated above. This allows us to obtain a good understanding of the different habits to be considered in order to create some savings when it comes to power. IEEE 1159 standard also refers to the recommended practice for monitoring electric power quality, which aligns with our purpose for this section so far.

Table 1.1: Duke Energy’s Appliance Operating Cost List [2]

Appliance Description	Appliance wattage, size and usage assumptions listed, determine the monthly kWh and cost estimate	Monthly kWh Estimate	Monthly Cost Estimate
Computer system left on	150 watts, 24 hours per day, PC, monitor, printer all left on with no sleep mode	108.0	\$8.86
Dehumidifier, runs constantly	400 watts, 24 hours per day, In “always-moist” location	288.0	\$23.62

Table 1.2: Duke Energy’s Appliance Operating Cost List (Cont.) [2]

Appliance Description	Appliance wattage, size and usage assumptions listed, determine the monthly kWh and cost estimate	Monthly kWh Estimate	Monthly Cost Estimate
Dehumidifier, cycles 50% of the time	400 watts, 24 hours per day, normal application, cycling 50%	144.0	\$11.81
Dryer, clothes	5500 Watts, 6 uses per week, average family of 4, 45 minutes per load	83.0	\$6.81
Evaporative cooler	325 watts, 24 hours per day, always on	234.0	\$19.19
Fan, attic fan	400 watts, 12 hours per day, in home ceiling, exhaust to attic	144.0	\$11.81
Fan, furnace fan	500 watts, 24 hours per day, ½ HP, always on	360.0	\$29.52
Freezer, old	450 watts, 24 hours per day, medium size	97.2	\$7.97
Heater, high heat setting	1500 watts, 3 uses per week, portable heater, cycling 50%, 12 Hrs per use	116.1	\$9.52
Heater, low heat setting	750 watts, 3 uses per week, portable heater, cycling 50%, 12 Hrs per use	58.1	\$4.76

Table 1.3: Duke Energy’s Appliance Operating Cost List (Cont.) [2]

Appliance Description	Appliance wattage, size and usage assumptions listed, determine the monthly kWh and cost estimate	Monthly kWh Estimate	Monthly Cost Estimate
Heater, constant use in warm space	1000 watts, 24 hours per day, portable heater, cycling 50% in warm living space	360.0	\$29.52
Heater, constant use in cold space	1500 watts, 24 hours per day, portable heater, maximum heat in cold space	1080.0	\$88.56
Heat lamp	250 watts, 24 hours per day, always on, in a cold location	180.0	\$14.76
Hot tub heater, electric	5500 watts, 3 uses per week, 2 hours per use, heating only when tub is used	141.9	\$11.64
Hot tub heater, electric	5500 watts, 24 hours per day, heater left on, insulated tub and covered, heat cycles 15%	594.0	\$48.71
Hot tub heater, electric	5500 watts, 24 hours per day, heater left on, poorly insulated tub and/or no cover, heat cycles 50%	1980.0	\$162.36
Hot tub pump	300 watts, 24 hours per day, low speed, circulation pump	216.0	\$17.71

Table 1.4: Duke Energy’s Appliance Operating Cost List (Cont.) [2]

Appliance Description	Appliance wattage, size and usage assumptions listed, determine the monthly kWh and cost estimate	Monthly kWh Estimate	Monthly Cost Estimate
Humidifier, tabletop warm mist	300 watts, 24 hours per day, always on	216.0	\$17.71
Humidifier, console cool mist	170 watts, 24 hours per day, always on	122.4	\$10.04
Lighting indoors, small home	600 watts, 5 hours per day, for average family of 4, 8) 75 wt bulbs	90.0	\$7.38
Lighting indoors, well-lit larger home	1875 watts, 8 hours per day, 25) 75 wt bulbs, many ceiling can lights or home office well lit	450.0	\$36.90
Refrigerator, over 10 years old, medium size	600 watts, 24 hours per day, rough estimate based on 4 in a family	143.9	\$11.80
Swimming pool filter pump	700 watts, 24 hours per day, ½ horse power	504.0	\$41.33
Swimming pool filter pump	1400 watts, 24 hours per day, 1 horse power	1008.0	\$82.66
Swimming pool filter pump	2100 watts, 24 hours per day, 1.5 horse power	1512.0	\$123.98

Table 1.5: Duke Energy’s Appliance Operating Cost List (Cont.) [2]

Appliance Description	Appliance wattage, size and usage assumptions listed, determine the monthly kWh and cost estimate	Monthly Estimate kWh	Monthly Cost Estimate
Water heater, electric, general use	4500 watts, 24 hours per day, cycles on 8% average for family of 4. Heater located in warm space	259.2	\$21.25
Water heater (this is additional use if clothes washer uses hot wash)	4500 watts, 8 uses per week, average for family of 4, hot wash, cold rinse (40 minutes recovery time)	103.2	\$8.46
Water, well pump used for irrigation	1600 watts, 4 hours per day, 1 HP	192.0	\$15.74

3.2.1.2 Analysis of data

As seen above, power monitoring can be very beneficial to reduce the energy consumption of a home. Once the user knows what appliances consume the most power, he or she will be aware and will pay special attention to those elements. However, assuming that every user will actually research about power consumption in his or her house is misleading. Therefore, after obtaining the previous data, we will be able to monitor the specific appliances that consume the most power at home, and the user will be notified in order for him or her to take action regarding this issue.

IEEE 1621 talks about the standards for the user interface for power status control of electronics for home environments. Hence this can be used as a guide for our project, we will take care of those appliances, so the user does not have to deal with the research. The appliances we will include are the washer/dryer, water heater, cooling/heating system, lighting system, clothes dryer, refrigerator/freezers, dehumidifier, and stove.

3.2.1.3 Power Monitoring Options

There are some different ways on how to measure power. One way is to read the wattage of each appliance, which can be found stamped in most of them: on the back, bottom, or nameplate. After the wattage is known, the user can multiply that wattage by the amount of time the appliance was running and the watts per hour consumed by the machine. In this case, the wattage is not exactly the same the appliance uses every time is used; instead, the power consumption responds to the specific settings in which the appliance is currently set up; therefore, monitoring the real-time

power being consumed by the same in this way, can be inaccurate. Since electrical power is the rate of energy consumption as currents flow through various parts comprising a circuit, another way of obtaining the power utilized by an appliance is by multiplying the electrical current draw by the voltage utilized by the same appliance. The current must be measure in amperes, and the information can also be found in the appliance itself. Moreover, the voltage needs to be in volts, and voltage rates are standard in most countries. For example, in the United States of America, most of the appliances use 110-120 Volts while some of the larger appliances use a voltage range of 220-240 Volts. To obtain the watts per hour, the user can use the same procedure as the one mentioned above. However, this method, as the one specified above, does not yield accurate results, just a rough estimation. For more details IEEE 1851 specifies the standard for design criteria of integrated sensor-based test application for household appliances, which can be related to the process we are researching for S.H.A.P.E.R.

Moreover, since energy saving has become a major concern in our society, some helpful information can be found in many websites such as the ones corresponding to Duke Energy and Energy Star. Such websites provide the user comparison tools that are helpful to understand how which appliances draw more power than others and some power consumption estimation according to the user data. Once again, this method is not very reliable when the user expects to obtain precise information. On the other hand, another way to monitor power will be through the use of some device that measure the specific power consumed by a specific appliance. The “Kill-A-Watt” compasses the required specifications. It has the options of measuring RMS voltage as well as current and active and apparent power as basic features. There are some other “Kill-A-Watt” that offer more features such as yearly, monthly, and annually cost for a higher price. This is an excellent way of monitoring power per appliances; however, in our project context would not be preferable because one “Kill-A-Watt” device will be needed per appliance, which can result in a very expensive project cost. Other way would be to buy a commercial power meeting which can be used for monitoring purposes, but those can also be really expensive, and will not be cost efficient to incorporate it into our project. Finally, then best option for our project is the insertion of an IC that is capable of provide real time measurements of AC/DC power supplies giving a less expensive option of monitoring power since each IC will cost less than three dollars per unit. In addition, more than the needed quantity can be purchased in case one is defective. Moreover, project wise, having an IC per appliance is more convenient because if one of them breaks, the whole system will not be affected, only the specific appliance.

3.2.2 Wireless Networks and Communication

A wireless connection has to be set up between S.H.A.P.E.R. and the device were the user interface is going to be established so information such as the power consumption can be transfer and interpreted by the software. This will allow the interaction between the user and the system from another device. There are different technologies in the market that can create this connection we are looking for. The most popular ones are Wi-Fi, Bluetooth and Near Field Communication (NFC).

3.2.2.1 Wi-Fi

Wi-Fi is one of the most commonly known forms of wireless communication between numerous devices. By the use of radio waves the internet signal can be transmitted and creates a network where devices can interact with each other. This technology is commonly used in the industry by various electronic companies to allow Internet connectivity for cellphones, television, laptop computers and now a days it is being integrated in different items in a Wireless Local Area Network (WLAN). As expected, in order for us to implement this kind of technology in our project a router is needed to transmit the radio waves at the right frequency. Something to keep in mind are the government regulations that have to be considered in order for someone to transmit information without interfering with a different transmission keeping in mind that it has to be secured to avoid security breaches and having to deal with someone hacking into the data being sent and the way it is managed in the system. In the United States, The Federal Communications Commission (FCC) dictates the standards to be considered in order to transmit a signal for frequency allocation. IEEE 802.11 talks about the MAC and PHY specifications for implementing WLANs in the 2.4, 5 and 60 GHz range. From the 802.11b technology with a frequency band of 2.4GHz and a bandwidth of 11Mbps to the 802.11ac with 5GHz and 1.3Gbps it is known that these are bands that do not require a particular license to operate.

Some of the key advantages of using Wi-Fi are the wireless factor that allows the user to easily move from one place to another between points without having to disconnect and allowing the flow of data to be possible ideally without any interruptions. Additionally, makes collaboration between two or more entities simple since now a days you can simply connect a smart television and your smartphone to the same Wi-Fi network and this will allow them to interact and create processes such as screen mirroring of your device into the smart television screen without using any kind of wire connection. However, the biggest drawback of using this technology is security. Even though there exist methods to secure a network through Wi-Fi security algorithms such as WEP, WPA and WPA2 which provide high security somebody can hack into the network by guessing your password or simply if the code is provided by someone else. Moreover, if the user connects to a public network more than likely the security is turned off in the network to allow easiness of access for all the users which more than likely means that the information being sent is not encrypted and has access to this information just for being within the range the connection is established. As it can be seen, even though there are security concerns associated when using Wi-Fi networks it is very safe to say that it can be very reliable (when used wisely) because of all the flexibilities that it provides at a friendly price. This popular technology can be of great use for S.H.A.P.E.R. since it can easily transfer the information (such as the power consumption) provided by the system via internet and it can be viewed by any internet or Wi-Fi capable device without having to worry about an Ethernet connection and compromising the user's mobility.

3.2.2.2 Bluetooth

Similarly to Wi-Fi, Bluetooth also uses radio waves to interact with any other Bluetooth-enabled device. It is covered under IEEE 802.15.1 standard for short-distance transmissions from 2.4 GHz to 2.485 GHz. This type of technology commonly operates with a frequency of 2.4GHz and is particularly designed for fixed and mobile devices within a short range of distance and a low transmission rate. Once a device connects with another one via Bluetooth it creates a Personal Area

Network (PAN) to transmit information between them. Hence, less information can be transferred when using this technology and it is commonly used for items such as wireless keyboards, smart watches, speakers, etc. Because of its nature Bluetooth technology uses less power than Wi-Fi which makes it a great choice for the under-development network called the Internet of Things, which basically will allow the connection between multiple devices in a house such as a drying machine that are within a short distance. This device would send basic information such as the temperature or power consumption which is basically the kind of information that we are looking to transmit for S.H.A.P.E.R. Moreover, Bluetooth technology is free, easy to use and reliable since the probability of other networks interfering with the one being used are small because the signals used by the technology are low powered. On the other hand, the use of Bluetooth is limited to simple applications because the transfer speeds are not as fast as the one offered by Wi-Fi. Also, Bluetooth networks are easier to hack than Wi-Fi but the chances of them being hack are limited to the short range of transmission. Finally, even though the power consumption is minimum in the long run it can take a significant percentage of your battery life, this is the case for people with smart watches where a connections has to be established between both of the devices as long as you want to use it. Bluetooth is definitely another great candidate to use for S.H.A.P.E.R. due to the fact that it is a technology that is simple to operate and that has a power consumption that is adequate to the expectations of a smart house system.

3.2.2.3 Near Field Communication (NFC)

This type of technology only works within a very short range, unlike RFID it allows two way communication between two or more devices. Compared to Bluetooth the range of transmission is much shorter (less than 20 cm) to an extent where in newer integrations of the technology into smartphones it has to reach a point of contact between the devices for it to transmit. NFC sends information at a maximum data rate of 424kbit/s. IEEE 802.2 standard talks in more detail about how to support small applications with limited data transport requirements. Therefore, the power consumption is even less than Bluetooth and much lower than Wi-Fi. Because of the range of transfer between the devices there is no need to pair using a passcode or a security algorithm. In Addition, no personal information is being collected when setting up a connection to the point where is being used to make NFC payments in America by using your smartphone.

As it can be seen, NFC technology limits its usage to very simple task, it is not really used to transfer data as everyone believes such as the commercials from Samsung for the Galaxy S3 model where two people transfer pictures only by putting their phones in contact with each other. It turns out that what happens with S-Beam from Samsung is that once the NFC connection is established between the contact of both devices Wi-Fi direct is turned on and allows the transfer of files. Furthermore, NFC is widely used in what's called NFC Tags, which are programmable chips that are used to activate a particular command (such as the S-Beam file transfer from Samsung) but it can be used to set your cellphone's alarm once your phone connects with the NFC tag on top of your bedside table, or open your maps or music app once you place your cellphone on the cellphone holder in your car. This particular technology is not as popular (at least not yet) as Bluetooth or Wi-Fi and it limits its usage to only basic functions. Thus, for our project it cannot be used to transfer a constant flow of power consumption information, yet it can we used in a smart way to activate a specific set of commands once the user enters or exits a room or once somebody gets home.

3.2.3 Electronics Power Management and Supply

S.H.A.P.E.R. by its nature will need a power supply mechanism in order to operate. Also, when looking at the products from the competition in the market we noticed that they used a smart socket to control the flow of current and determine whether a device is on or not or how much the lights are going to be dimmed when using a dimmable light bulb.

3.2.3.1 Lead Acid Battery

This type of rechargeable battery has low energy to weight and volume ratio, yet it can supply high current and high energy densities depending on the design. The materials used for lead acid storage battery cells are PbO₂, Pb and H₂SO₄. Where, the positive side of the battery is made of PbO₂ the negative one is made of Pb. This positive and negative plates are introduced in H₂SO₄. Then current flows in an outside load connection to balance inequality of electrons, also called discharge of lead acid battery. If a DC source is connected electrons are then provided and allows the charge of the battery. It is considered to be the most economical option when it comes to larger power uses. The fact that it is a well-known technology provides dependable service to the point where it is mainly used in applications such as wheelchairs, cars, forklifts, etc. where reliability is a key factor. Additionally, it provides low self-discharge systems, it has incredible good rates comparing to other rechargeable battery systems while offering very low maintenance. Nevertheless, it is limited to be stored when discharge since it can damage it. Because of its low energy density considering the weight it can be utilized mainly for stationary or wheeled applications. Even though the battery can be fully discharged and recharged, it is limited to a certain number of cycles before it dies completely. If the battery is charged in an inappropriate way it can cause thermal runaway which means that the heat rate is much greater than what the battery can hold so it starts getting expelled from the battery to an extent where if the temperature keeps increasing the cells dry out and the container melts which can make it a non-environmental-friendly option. IEEE 1187 standard shows the recommended practice for installation design and installation of this type of devices in order to create a more secure environment for the user. Even though there are some limitations in safety and some environmental concerns this is a great way to supply the power needed to our system because of how reliable and affordable it is. In order for this type of battery to be used for S.H.A.P.E.R. the power extracted from the battery has to be converted to AC since this is the type of power that is used in most of the common house appliances.

3.2.3.2 PowerSwitch Tail II

PowerSwitch Tail is an isolated 5BDC tool that is used to switch and control power to 120VAC devices by using low-voltage circuits such as microcontrollers as shown in Figure 2. The first generation of this particular item was capable of switching 10 amps, versus the new one (PowerSwitch Tail II) which allows the user to switch 15 amps. The input is an opto-insulator, which means that it reduces the input power from the microcontroller to switch the AC-type circuit. It is mainly used to connect microcontrollers to different appliances around the house in order to it to perform home-automated tasks. The advantage of using this tool is that it makes tasks incredibly easy and safe at the same time by producing very fast and efficient switching speeds. Instead of using a large amount of wires, the user only has to connect low voltage control to the microcontroller and use a programming language of his/her preference to dictate the commands.

It has two ends, one of them connects to the user’s wall outlet and the other one has a female-type connection that allows connectivity with any appliances that can be found in a standard house. In between these two ends there is a block that gets connected directly to the microcontroller of preference. The way it works is fairly simple since basically once the microcontroller sets a ‘1’ or a ‘0’ the PowerSwitch Tail will open or close the flow of current to the end that connects from the wall outlet to the appliance being used. Keep in mind that IEEE C37.233 shows the user a guide for power system protection testing, since the user is going to be exposed to working with electrical connections that may cause harm. Additionally, this tool is affordable, safe and convenient. First, it is affordable since it has a price tag as low as \$25.99 for the standard version or \$28.99 for the Normally Closed version which gives the ability to be rewired. Secondly it is safe since there are no wires being exposed eliminating contact with dangerous voltages, it connects to the standard 120VAC 3-prong outlets without requiring any additional wiring and it comes with instruction manuals to facilitate its usage. Finally, it is convenient since it can be used with pretty much all the appliances found in the Americas, it can switch from 10 to 15 amps depending on the version, connects to the major microcontrollers such as Arduinos, Raspberry Pi, etc. without having to use a driver to run it or any additional kind of power supply. Moreover, it comes with LED indicators to show the status of the signal being controlled, it can control both 2-prong and 3-prong devices and it has a safety ground connection available for grounding the external control circuit which can be of great advantage to use for S.H.A.P.E.R.

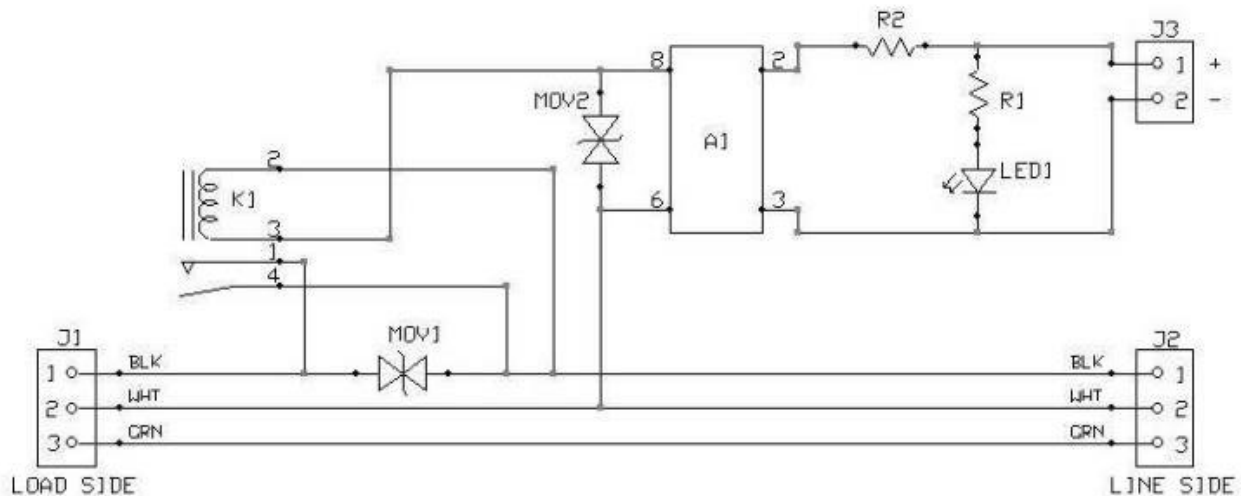

**Figure 2: PowerSwitch Tail II circuit diagram [3]
(Reprinted with Permission of the PowerSwitch Team)**

3.2.3.3 Relays

A relay is a great alternative to be used as a switch to control the flow of current that is going to be supplied from the source to the appliance or the component being used. It is used by the microcontroller directly to a device or a light bulb and thus can create a power or a light switch. One of the most common types of relays is the electro-mechanical (electromagnetic switch) relay, which is basically the combination of a mechanical switch and an electromagnet. It is used to alternate the current flow between terminals by supplying voltage. An iron piece is attached to the switch which is original placed in the upper terminal. An electromagnet is placed at the bottom so once the voltage is supplied to the electromagnet an electromagnetic field is created so the iron

piece is attracted and hence the switch is moved to the lower terminal. Testing requirements, service conditions, electrical ratings and thermal ratings are defined for this type of device in the IEEE C37.90 standard.

These components are very reliable and easy to construct, it doesn't require any type of programming so learning how to use them should not be a difficult task to achieve and they can be set and reset quickly without creating errors or having to debug an entire code to figure out if there is something wrong with it. Furthermore, electro-mechanical relays are designed to work with many types of signals with both high and low voltage characteristics along with DC and AC support in frequency ranges up to the GHz scale. On the other hand, they required constant inspection and they are known to be deteriorated with time since it has a big number of springs and linkages inside that become weak. This type of relay do not have a directional feature and its operation speed is limited by the mechanical inertia of moving components which also creates a lack of multifunctioning and limits the performance to only one function at a time. The electro-mechanical relay is available in latching and non-latching versions. The first type uses magnets to hold the switch to its original terminal a before the electromagnetic field is created and after the field dissipates. Non-latching ones have to have a constant current flow through the coil to maintain the relay in motion and it is set to stop the current flow once it received a pin low. Considering the fact that the size of the device cannot be big, it has to be able to achieve decent switching speeds, stop the current flow in the device when needed and stay in a default state with a low power consumption this relay can surely be of great use for the specifications required by the S.H.A.P.E.R. home automation system.

3.2.4 Occupancy and Ambient Light Sensors

As part of the S.H.A.P.E.R. system occupancy and Ambient light sensors need to be incorporated in order to get an input from the environment surrounding the user. As it is known, there are two popular types of sensors that are incorporated into nowadays home automation systems, occupancy and ambient light sensors. Occupancy sensors can detect via heat laser or ultrasonic applications if someone is getting into the room or simply leaving it, also they can sense if there is some kind of movement in the area. Moreover, ambient light sensors have as input the amount of light that is reflected to the sensor. Hence this can be used to differentiate if is day or night time; and set up specific conditions or scenarios in the system depending on the amount of light or brightness in the room.

3.2.4.1 Occupancy Sensors

As mention before, occupancy sensors are used to detect if there is physical existence in a room. If there is someone then it sets a condition to let the system know and create a response. Once the condition is set the system identifies presence in the room it communicates with the microcontroller so further actions can take place. For S.H.A.P.E.R. we would consider Ultrasonic, Passive Infrared (PIR), Surveillance Cameras and Microwave occupancy sensors.

3.2.4.1.1 Ultrasonic

Ultrasonic sensors come with the same concept of a RADAR or SONAR device or even the natural ultrasonic abilities that are found in bats. This strong frequencies are broadcasted such that if there is physical occupancy in the area the waves would bounce in the object and travel back to the sensor, act that would declare as positive the presence of something around the area. Other than being used to detect physical presence they are also useful when measuring speed or direction and when determining position. For the short description at the top it can be concluded that two type of devices are needed in order to make the transmission and reception of the waves possible, specifically a transducer and a detector. The transducer is in charge of converting the energy obtained from the power source and convert it into the ultrasonic frequency that is going to be used. They are made from piezoelectric crystals that change size when voltage gets applied to them. Hence, once alternating current is applied directly it vibrates very fast and emits the ultrasonic wave to be used. On the other hand, the detector also uses piezoelectric crystals but instead it will detect the existent ultrasonic wave and convert it into voltage, producing and opposite concept if compared to the transducer. By using both devices the user can tell the amount of time it took for the wave to travel from the transducer back to the detector. Ultrasonic sensors can be used in other applications in addition to the ones already mentioned, such as medical ultrasonography, alarms, humidifiers, etc.

Furthermore, the frequencies in this kind of sensors are commonly used in quiet places since they are inaudible to humans. IEEE C62.41.1 describes the behavior of voltage and current during this type of low-voltage environment for AC power circuits. Also, these sensors are also easy to design, consume low power and are relatively inexpensive if compared to other occupancy sensor products that can be found in the industry depending on the model. Since there are some designs that only need one device instead of a transducer and a detector since the same piezoelectric crystal can be used to transmit and receive the ultrasonic waves and some other designs allow the user to use both radio and sound wave in addition to the original ultrasonic ones. This is a very reliable type of sensor considering its price tag there are not really a lot of disadvantages other than the limited capabilities it has since the signal can be distorted with certain kinds of materials. As it can be seen ultrasonic sensors are definitely great devices to consider for S.H.A.P.E.R. because they are inexpensive, consume low power and can be used for a big variety of applications. Even though Ultrasonic sensors have their limitations when used for certain material, they fit the purpose of what is expected for this project.

3.2.4.1.2 Passive Infrared (PIR)

As their name states Passive Infrared sensors detect infrared light that is produces when in contact with an object around the area. They are very popular and can be found in multiple houses and public places due to their reliability and how affordable they are. There are a wide range of PIR sensors available in the market from a very professional use to a more ‘do-it-yourself’ type of applications, usually this last option is the most inexpensive one. The way it works is basically by using a sensor that detects the heat radiation being emitted from a particular object above an absolute zero temperature that is usually invisible to humans. Keep in mind that the sole purpose of this device is to detect those heat waves emitted from an object without generating energy, reason why it is called a passive infrared sensor. PIRs are usually 40 millimeters square long and

are made of a pyroelectric sensor which can detect the levels of radiation entering through the face of the sensor of a distance up to 10 meters away (the hotter the object is, the more radiation is going to be emitted). This device uses basic circuitry that consumes very low amounts of power. The circuit board is mainly made of resistors and capacitors, reason why it is also an inexpensive option to be considered. IEEE 2700 is the standard for the framework used in sensor performance specification for items such as terminology, units, conditions and limits for temperature and proximity sensors.

Moreover, PIR sensors have branched to PIR motion sensors which are mostly used to detect the movement of different objects in motion given a particular area of coverage. Usually, this can be found in automated lighting systems and burglar alarms. Since there could be objects emitting radiation in a room it would be challenging for a non-PIR motion sensor to identify if someone actually entered the room or not. This means that the system could get activated by itself which could be a problem for S.H.A.P.E.R. However, PIR motion sensors have the capability of detecting if there is a change in the temperature and surface characteristics of whatever is in front of it. Hence, when an object that is emitting heat waves passes by the coverage area of the sensor it will identify the temperature changes and convert this changes in radiation to a change in the output voltage and trigger the detection. There might be objects that have similar temperatures when comparing it to the temperature of the area, but with a different radiation emission pattern compared to what was being detected before, triggering a detection as well. The reason why most of this sensors have a plastic window on top of them is so it is easier for the heat wave to enter and be detected since the coverage area is being expanded. Even though this type of sensors have a very large coverage area to detect physical presence and movement, sometimes they are inaccurate because there could be multiple object around the area with similar temperature variant. Therefore, if accuracy is a big concern the price is compromised as well. This type of device can potentially be used for S.H.A.P.E.R. because of its effectiveness when detecting objects around the area. Nonetheless, we have to make sure that the model selected doesn't compromise the price so much to the point where it would deliver a poor performance.

3.2.4.1.3 Surveillance Cameras by Using Software

Probably one of the most inexpensive options when considering what the user is getting from the investment. You can use your cameras not only for video surveillance like we are much familiarized too but also for motion detection by utilizing software that can detect if there is a difference in the input being obtained from the camera. The advantage of doing this is that the system does not require any other type of hardware which is even better if the user already owns a camera and a computer. A special calibrator utility is provided in the software which basically obtains the 'real scene' picture and it gets updated every second with a fresh images. The algorithm is based on Background Subtraction which allows the program to detect changes in the video frames to come with the exception of what is considered normal background changes such as daylight.

The camera calibrates the current image that is being displayed and visualizes actual detectors as dots on top on the image. These dots can also be found around sharp edges or lines and allows certain degree of sensitivity to pixel noise in real time. The image being displayed in the calibrator is divided into cells, each cell analyzes certain amount of pixels and determines if there is motion

present in the area or not. IEEE 1900.6 shows the user the standard for spectrum sensing interfaces and data structures for this type of system. Depending on the preference of the user the software can also dictate to what extent the cells were modified and classifies the output as 'no motion', 'possible motion' and 'motion'. Hence if there was a minimal degree of disturbance the systems still alerts the user, with the advantage that in some systems the user can review what was being recorded at that moment and take advantage of the multiple features this type of device offers. Even though this option is very useful and revolutionary it is very convenient if you already have a camera and a computer. However for S.H.A.P.E.R. we would have to purchase the actual camera and the software which can be a little more tedious than just getting a different type of sensors, yet this will still be considered as a possible options if the basic requirements can be fulfilled.

3.2.4.1.4 Microwave

Microwaves are electro-magnetic radiations with broad bandwidth and high data transmission rates. The frequency averages between 0.3 GHz to 300 GHz and are mostly utilized for non-broadcasting applications. Microwave devices can detect an object's motion between certain ranges of distance. They consist of detectors that emit microwaves into a particular region and detect if there is an object present by inspecting the microwave signals received once they become in contact with it and produce a reflection. In more detail, once the signals are release they carry a specific frequency that gets modified (by switching the phase) once someone is moving around the area of range. After the altered waves are reflected back the receiver performs a phase analysis and identifies a change in the signal. Nowadays this type of sensors are used for different applications such as security alarms and door openings, detect heartbeat and breathing rate of a human, in traffic law enforcement, home automation systems, among many other things.

The advantages off using this kind of technology are that they can be used in harsh environments where the temperature plays an important role and infrared motion sensors would basically be useless. Also, since microwaves are a form of radiation they can easily penetrate walls and object which expands the range of scope. In addition, when combined with infrared detectors become more accurate reducing the amount false alarms in a security system. IEEE 1851 standard shows the design criteria for testing household appliances based on this type of sensors. On the other hand, they require big amounts of power supply in order to operate which makes it not as efficient as different types of sensors. Because of this problem they work in intervals, which means that the sensor is not being in used all the time which also would affect the performance of a home automation system if someone gets in the room and at that particular point the sensor is idle.

3.2.4.2 Ambient Light Sensor

Ambient light sensors detect the amount of light present in a particular are and can be found in different types of control systems in the industry. The goal with this type of devices is to imitate the human eye since humans are more than likely the end user depending on the application. However, a standard model of these type of sensors are also sensible to different types of lights our eyes cannot detect such as infrared or ultraviolet lights; this can be fixed with certain modifications, more materials and money are compromised. The reason why we would like to use these type of sensors for S.H.A.P.E.R. is because it can be used for many applications such as if it is day time or night time or also to dictate if there is someone in the room once they turn on the

lights. By the system recognizing that it is a specific time of the day or that someone is in the room it can send certain conditions such as changing the AC temperature or dimming the lights in a particular area in the room to a certain level. For part of the most popular types of ambient light sensors we have photo resistors, photo diodes and photo transistors.

3.2.4.2.1 Photo Resistor

This type of device is characterized for being a light-controlled variable resistor. This means that the resistance in a photo resistor is proportional to the amount of light in a particular area. This means that the darker it is, the more resistance the device is going to achieve and vice versa. Usually if it is exposed to light it will have a resistance of a few ohms, yet if it is dark it can achieve up to the mega ohms scale. Basically, the frequency that can be found in the light is absorbed by the semiconductor material and give sufficient energy to the electron to jump into the conduction band, which make the resultant holes produce electricity and lower the resistance. Photo resistors are commonly found in electronics such as cameras, outdoor clocks and a plethora of solar-based devices. Among the advantages for this type of devices it is known that they are solely dependent of the amount of light they receive, which means that less interference can be expected when part of a particular environment. This type of devices are also easy to manufacture and hence very inexpensive because they simply consist of a semiconductor with a conductive pathway to both ends. Similarly to PIR sensors, IEEE 2700 standard goes in detail about the terminology, units, condition and limits for this type of ambient light sensors. They are in the millimeter scale when it comes to size, which means that they can fit pretty much in most of the electronics and electrical networks that can be found in the market. Because of its nature the amount of power that is consumed by this type of device is very low which is great for basic applications such as a home automated system like S.H.A.P.E.R. On the other hand, these types of devices also show difficulties when exposed to low light levels which restricts their usage under certain conditions. Additionally, if the level of light are too high it also shows difficulties. It will work, but it will take more time to assimilate the change in the brightness. Also, since they are very inexpensive and mass-produced it is common that every now and then some of these come defective or break easily, reason why if this type of device needs to be ordered we would need to purchase a big amount of them just in case.

3.2.4.2.2 Photo Diode

This is also another semiconductor device that works with light directly to achieve a particular task. In this case photo diodes absorb the light present in a particular environment and converting it into current. Usually optical filters can be found on these type of devices on the surface area. This surface area is proportional to the response time of the device. So the bigger the surface area the more time it would take to convert light into current. Other than the optical filters, one of the biggest difference between a photo diode and a regular semiconductor diode is the fact that photo diodes use PIN junctions instead of regular P/N junction to increment the response time. Also, this type of device operates in reverse bias instead of forward bias. The user can refer to IEEE 255 standard to learn further about the letter symbols for electrical quantities and parameters applied to semiconductor devices. Once the light hits the device it creates an electron-hole pair that when absorbed in the depletion region of the diode the carries move from the junction by the built-in

electric field producing current. The total amount of current in this device is the sum of the current produced when it is exposed to light plus the one produced when it is exposed to dark.

If compared to other similar devices it has very good output current for the amount of light coming in in addition to a longer wavelength and a low noise without requiring high amount of voltage to turn on. Also, it is very low cost device with a long lifetime and a very compact and light weight design. On the other hand, the surface area is very small so not a big amount of light can come in. Compare to more expensive devices the sensitivity to light is not that high and it can show a slower response time. As it can be seen, photo transistors are great for applications such as solar panels where the light can be converted into current or voltage. However, what is ideal for S.H.A.P.E.R. is a device that can be used to detect alight a set a particular conditions; for this particular kind of application a photo resistor seems to be a better option.

3.2.4.2.3 Photo Transistor

Similarly to photo resistors and photo diode this is a semiconductor light sensor created from a basic transistor that provide better sensitivity than a photodiode. Compared to a regular transistor, this device has a much larger base and collector areas. The light enters the base region where it produces hole-electron pairs and the device also operates under reverse bias in the base-collector junction. These hole-electron pairs move under the influence of an electric field and provide the base current while making electrons move to the emitter side. If the emitter is left disconnected the device will act as a photodiode. For more information about this type of device please refer to IEEE 218 standard to learn more about the methods of testing transistor devices. However, compared to photodiodes, phototransistors have a higher responsivity for light, while compromising the detection amount for low light scenarios and the response time since it is higher. This type of device is inexpensive, simple and easy to integrate in many electronics because of its convenient size. Also, they can produce an output almost instantly and produce a voltage that photo resistors are not capable of. On the other hand, they can't handle voltages over 1,000 volts since they are made out of silicon, they are vulnerable to spikes of electricity and electromagnetic energy and they don't allow electrons to move as freely as other devices do. Therefore, as we can see this type of device is great for supplying voltage or current by emitting light. Yet, it is also used in applications such as security systems, electric controls, relays, light control, computer logic circuitry, among others.

3.2.5 Operating System Compatibility

S.H.A.P.E.R. will be interacting directly with different components in the environment such as sensors, lightbulbs, and thermostat among other appliances. However, there has to be a way for the system to interact directly with the user, here the user would have the ability to see the power consumption for a particular period of time and also tips to improve these. Moreover, the user would have the ability of controlling certain components in the system such as controlling the brightness in a particular room in the house, turn on/off the lights, decrease and increase the temperature in the house, etc. Since we are entering in the era of the Internet of Things it would make a lot of sense to design something related to that. The easiest and quickest way to communicate with the system would be by using operative systems that were already developed, that are reliable and come with many features built-in already such as a library for voice

recognition commands. Hence, we will consider Mac OS, iOS, Android, Windows Mobile and Windows for this particular section.

3.2.5.1 Mac OS

Mac OS consist of different versions of operating systems for the Macintosh line of computers developed by Apple since 1984 until today. This operating system has been broken down into two types of architectures, the Classic Mac OS and the OS X. Classic Mac OS was used up to major revision 9 in the year 2000 and OS X built upon that foundations but a major update was performed and it is still used nowadays. A big advantage of the Mac OS is that it was to deliver an experience outside of what the user is usually used to since it is created to minimize they awareness of the actual operating system running. Different gestures using the mouse and graphic controls were integrated for easiness of use. Hence, if the user was not much familiarized with a computer this would facilitate their learning experience by making it simple and responsive. Additionally it was possible to update to a newer version by using a floppy disk with a copy form an Apple dealer. Apple has always being known for creating reliable products, so by choosing a device that runs this type of operating system the user will make sure that it would run as advertised. Comparing to other operating systems in the market it is known to be cleaner a more stable. Mac OS is very exclusive and doesn't branch out to different brands in the industry, since it is designed for a limited amount of computers the user does not have to worry about drivers or getting delayed updates when a newer version is released. Mac computers are also very secure since no third party programs can be installed and the majority of viruses out there are designed for Windows computers which certainly increases even further the chances of getting a virus in this type of platform. Even though there is a limited amount of software programs in comparison to other operating systems, there is a large library of free open source applications designed for Mac computers specifically. On the other hand, all of these great features come with a price tag, since they are expensive products. Also, there are not many customization options available and many software applications take longer to be released for this type of operating system. There are not many upgrade options when it comes to hardware and if there are any they are very expensive. Hence the easiest way of upgrading a Mac computer running Mac OS will be to replace it for a newer model which causes an impact in the contamination of the planet. Please refer to IEEE 1680.1 standard to learn more to the criteria for the design of personal computer products to reduce the environmental impact. As it can be seen, Mac OS is definitely reliable and a great choice when it comes to performance. However, it is expensive and the amount of applications that can be used are limited. If we were to develop a software application for Mac it would be more expensive and tedious than other options, it is an excellent tool to have but probably not the best fit for this particular type of project.

3.2.5.2 iOS

Apple's iOS is a mobile operating developed for the line iPod Touch, iPhone and iPad devices. The first release was for the first generation iPhone in 2007. This revolutionary operating system is based on a 'direct manipulation' concept. Which basically means that the user interface is controlled using multi-touch gestures such as swiping, tapping and pinching. For certain applications the accelerometers inside of the device allows interaction by shacking or rotating the device as well. The whole objective of creating iOS was to 'shrink' the experience found when

using Mac OS so the user would carry it in their pockets wherever he/she may go. IEEE 1003.1 defines these terms, concepts, interfaces and conventions used for portable operating systems. In addition to the great ability of controlling the device using a touchscreen, being able to download third party apps from different developers was something that also completely revolutionized the industry, so many ideas from so many different people at a low price (if not free) in the Apple App store. Since this operating system has a foundation Mac OS it has similar characteristics such as making the whole experience based in the user's satisfaction. Hence, iOS is very user friendly and typically people that have not owned a smartphone before find iOS a very comfortable experience. Similarly as Mac OS iOS does not let the user install app from unknown sources which can put a limit in what they can do, yet it prevents the device to get corrupted since only developer associated with Apple can create the Apps that can be found in the App store. However, the user has the capability of 'jailbreaking' the device which allows the installation of apps developed by unknown sources by using a software called Cydia which is similar to the Apple App Store. However, the disadvantage of jailbreaking the device is that it is not authorized by Apple so they are not responsible for anything that happens to it, as a matter of fact the warranty of the device is voided instantly if they found out. For Internet of Things purposes this is a great way for the user to interact with the system directly and is very user friendly. Additionally, all of the latest Mac OS and iOS come with the voice assistant Siri, which integrates a whole voice recognition library in the system. This could be very useful when using the operating system to interact with S.H.A.P.E.R. to perform certain actions. Nevertheless, Apple offer very little room for personalization and themes and if we were to develop an app using this type of operating system it would be a little tedious since in order to develop apps a membership to the Apple Developer Program is needed, this has a price tags of \$99 per year. In case for S.H.A.P.E.R. we would only need to develop one app to be used with an iOS. Even though Apple has shown that their products are very reliable and efficient it is challenging to develop our interaction tool for S.H.A.P.E.R. if we have to pay for a membership yearly fee since we have to subject to our initial budget without risking the warranty of the product we would be using for this project.

3.2.5.3 Android OS

Android is a mobile operating system created by Google for a big variety of smartphones and tablets. Similarly to iOS from Apple, Android OS works using direct manipulation by swiping, tapping and pinching. It was originally released in September of 2007. The same year they created an alliance with big cellphone companies such as HTC, Sony and Samsung and was released in wireless carriers such as Sprint, Nextel and T-Mobile. In the past few years, extensions of the operating system have branched out to different markets such as Android Wear, Android Auto and Android TV. Some of the big advantages of using Android operating system is the fact that it allows a lot more advanced features that iOS, such as widgets, an application menu button and a home screen, great multitasking capabilities and easy access to notifications. By using widgets the user has access to direct app commands in the home screen without having to open the app, wait until it loads and then selecting the desired command. Having a menu button and a home screen to add short cuts is consider by many a great advantage, since all of the apps are integrated in one section without taking a lot of space from the home screen. This allows a more personalized experience since the applications that are used the most can be simply stored there and also allows the integration of widgets for the user's convenience. Android introduced multitasking on smartphones, which for example allows the reproduction of music and videos from an app while

using a different app, or even talking on the phone while looking for an address on the internet. Also, Google introduced easy access to notifications from the notification bar at the top of the screen. Before, the user would receive a pop-up with a short description on the screen and then would have to enter the application to check what the notification was. Similarly to iOS, IEEE 1003.1 goes in more detail about the standards used for portable operating systems by presenting the terms, concepts, interfaces and conventions. On the other hand, there is a big amount of companies using this operating system which basically allows the manufacturer to use least expensive components to achieve a good price tag, but the performance of the device is compromised particularly when using an application or game that is made for newer and more advanced devices. Also, one of the biggest drawbacks of the first generations of Android devices was the fact that even though multitasking was achieved for some reason the applications would still run in the background which consumed a large amount of RAM in addition to a more aggressive battery life consumption. This big issue was fixed a few years ago once Android Ice Cream Sandwich was released since it allowed the user to still take advantage of the multitasking capabilities of the device and once he/she was done with the task it gave the ability to close or terminate the process being performed by the system.

In addition, Android allows the installation of unknown source applications outside of big variety that can be found in the Google Play Store, (which is like the Apple App Store for iOS). This can be bad and good at the same time. Bad since if a malicious app is installed, it can grant access to personal information and files to other people and install all sorts of malware in the device. Nevertheless, it can be great if this feature is used for good purposes. Amazon for example has a basic application in the Google Play Store but also has one with a bigger variety of features outside. Becoming a developer of Android applications is fairly simple as long as the person knows how to do it. Google makes it easy by providing all of the tools and allow publications of these apps for free in the Google Play Store. Obviously, if an app that was posted is reported with bad feedback it gets taken out to avoid problems with more users in the future. Therefore, we can take advantage of this fantastic feature to create an app for our home automated system at a low cost. Moreover, since there is a big variety of Android devices in the market it is fairly inexpensive to get a device such as a tablet running the operating system. Once the application is developed we can allow the S.H.A.P.E.R. to send information about the power consumption or to connect with a particular appliance via Wi-Fi or Bluetooth technologies. This type of operating system also offer a great voice recognition software. This software and its library can be used for the user to dictate voice commands directly to the system and do actions such as dimming the lights, controlling the temperature in the house, etc. As a great alternative, or side project we could develop an Android Wear app that receives voice commands from the user by using his/her watch. Therefore, if the user is getting home from doing groceries and the hands are full of groceries voice commands can be used simply by utilizing a smart watch. As it can be seen Android offers a lot of great features at a great price and convenience, it surely is at the top of the possible operating system to be implemented for this project.

3.2.5.4 Microsoft Windows OS

Microsoft Windows consist of a series of operating systems developed by Microsoft. It was first introduced on November 1985 as a graphical operating system shell for MS-DOS since there was big opportunities for any company working directly with graphical user interfaces. From a market

share point of view, Windows has been dominated the computer market in comparison to its bigger competitor Mac OS from Apple. Even though Windows has experienced a decay on their sales because of the introduction of the smartphone (where Android sale dominates) Microsoft still dominates the personal computer market with this powerful operating system. Microsoft branched their operating system between different families depending on what they were going to be used for. Windows breaks down into Windows, Windows Server and Windows PE, Windows Phone and Windows Embedded. The regular version of Windows is made for personal computers and is the one that is mostly used around the globe. It breaks down into the operating system a lot of people is familiarized with such as Windows XP, Windows 7, Windows vista, Windows 7, Windows 8, Windows 10, etc. Their main competitor is Apple's OS X. Also, as it names describes it Windows Server is designed for server computers. Among the many advantages it offers for this type of usage it is important to identify Active Directory, DNS server, DHCP server and Group Policy. The biggest competitor for this family of Windows operating systems is Linux. Windows Preinstallation Environment (or Windows PE) is a lightweight version of Windows and is mostly used in the troubleshooting and deployment of PCs, workstations and servers. Windows Phone was created for smartphone to compete against the big success of Android devices, it will be explained in more detail in the next section. Additionally, Windows Embedded is an operating system developed for embedded systems. Windows embedded can be found built-in in different OEMs that manufactured their products using this option. One of their competitors for this type of operating system is Texas Instruments. Based on the specifications seen above we would be using the regular version of Windows available for personal computers.

Among the advantages of Windows we have the fact that compared to other operating systems for personal computers it is fairly simple to use and it has backwards compatibility, so if the user is in a need to upgrade his/her computer all the information saved in previous versions of Windows can be used in newer ones. When comparing to an operating system like Mac OS, there is a big variety of software available in the market, also popular software is first release in for this operating system. When it comes to hardware is the same thing, and if there is an outdated type of connection to the computer the user can simply purchase an adapter and look for the drivers (is necessary) to make it compatible. Since Internet Explorer was bundled with Microsoft Windows most of the websites were first developed for this operating system which gives Windows a better compatibility with Microsoft driven websites. On the other hand, some of the limitations of using this operating system are the fact that in order to keep up with technology and the operating system requirements the user has to constantly update the hardware on his/her device such as a faster processor, more internal memory, a larger hard disk which also contributes a lot for a negative impact to the planet. Also, refer to IEEE 1680.1 standard to learn more about the design criteria of personal computers in order to reduce the environmental impact these type of products cause. Moreover, comparing to Mac OS, the security that is implemented for this operating system is very low so if the system is compromised someone else can have access to personal information and the user wouldn't know since the system does not keep any kind of log files to prove other user's presence. Additionally, as stated before Windows OS is more susceptible to viruses as well since the majority of the existing ones are created for this particular operating system. Hence, the user has to constantly invest in antivirus software and make sure they keep it up to date with the newest versions. Also, Microsoft slips in a large amounts of terms and condition that allow them to control the user's personal computer software which limits the amount of privacy to the point where it can get to be questionable. There is a big amount of people that is not aware of this even though it is

stated in the End User License Agreement before the product gets installed. As it can be seen Windows is definitely one of the top choices because it is the most commonly used operating system. It branches out to satisfy every single type of customer in the market and it does it in a very efficient, productive and affordable way. Probably one of the biggest advantages of having using this operating system for this project is the fact that it satisfies the need for the kind of operating system we need at a very convenient price. The user could have access to S.H.A.P.E.R. through a software in his/her personal computer or also by using a web browser that can direct them directly to it. By accessing the system remotely the user would be able to control the lighting system, the air conditioning temperature and look at different power savings tips from the convenience of their office and even a different state or country.

3.2.5.5 Windows Phone OS

This series of operating systems is based in the original Windows Mobile operating system for Windows Smartphones, which had as a foundation the regular Windows operating system everybody knows for the personal computers. One of the main difference between Windows Mobile and its predecessor is that Windows Mobile was created for the enterprise market and its newer version for the consumer market. It started with Windows 7 in October of 2010, which provided the basic features that can be found in a smartphone such as the user interface using touchscreen technology, text input, messaging, web browsing, email, multimedia support and office suite to organize Microsoft Office apps and documents. Then, it was succeeded by Windows Phone 8 in October of 2012 which integrated multitasking capabilities, Rooms for group messages, Driving Mode, Data Sense, NFC and Wallet along with many other features such as xbox SmartGlass which allows the user to control an Xbox 360 and Xbox One with their phone. Later Windows 8.1 was released and added new features such as Cortana, Battery Saver Mode, and Wi-Fi Sense along with many other updates. Finally, its newest release has been Windows 10 Mobile, which was recently released in November 2015, which aims to create consistency with personal computer and has integrated features to provide a better synchronization with this type of devices. One of the most popular new updates is the integration of an app that allows the user to control personal computers, Xbox consoles and mobile devices that are running a version of Windows 10. In addition to a user interface that provides the user with a “PC like experience” by connecting the phone to a docking station that allows connectivity with other hardware devices such as a mouse, keyboard, monitor, etc. Hence, it allows the user to run a more sophisticated version of Windows wherever they go only using their mobile device. Please refer to IEEE 1003.1 standard to learn further about the terms, concepts, interfaces and conventions used in portable operating systems. Moreover, the Windows store is known for having a limited amount of apps. Nevertheless, Microsoft is working in creating a bridge to support platforms such as iOS and Android which (codenamed “Islandwood”) and possibly bring some of the applications to this operating system as APK files for the case of Android. Among the advantages of Windows Phone OS we have a new and improved interface thanks to the Small Tiles in the home screen which provides a big amount of customization features to the consumer, a new Action Centre for notification and toggles such as Wi-Fi, Bluetooth, Airplane Mode, etc. Also, a better gaming experience with Xbox game, and a very stable experience when running heavy files or apps. On the other hand, currently there is no file manager to explore the content in the device, there is no antivirus app to prevent your devices from getting compromised or corrupted, there is no flash support when browsing the internet and as mentioned before the Windows store is very limited when it comes to the amount

of app available for the user to download compared to the Apple App Store or Google Play. As it can be seen, the Windows Phone operating system brings a lot of features to the user, especially because of how reliable it is and the new features integrated in their new mobile operating system surely look very promising. Even though Microsoft dominates the personal computer market with the regular Windows operating system they still have large path ahead of them to compete against Android or iOS. In order for somebody to become a developer for Microsoft and post apps in the Windows Store they need to pay a fee of \$19 if the user is an individual of \$99 if it is for a company. This offers the developer a less expensive option compare to Apple, yet Android still a better deal since they allow you to do it at no cost. The Windows Phone operating system could be a good choice for our project, yet something to consider is that Windows Phone devices can be more expensive than Android ones and in order to get a developer license there is a fee to be consider. Even though there is still a big path ahead of Windows Phone to match its competitors its reliability and customization features definitely make it a good choice for S.H.A.P.E.R.

3.2.6 Microcontroller

The S.H.A.P.E.R. is a home automation system which its main purpose is to save energy. Information regarding power consumption, room occupancy, and ambient lightning of the whole circuit will be gathered by a central component that will control the system functions accordingly. In order for this to be possible, a central processing unit (CPU) is the most efficient option because designing an analog circuit that includes all the desired features will be time and money consuming. Microcontrollers act like CPUs for this type of applications. A microcontroller is an integrated circuit that acts like a small computer. Its main components include, but are not limited to: processor core, memory, and programmable input/output peripherals. The microcontrollers are used as embedded components in other applications because they are particularly useful in automatically controlled devices. They can be found in automotive systems, appliances, office machines, garage doors, etc. Its ability to utilized RISC instruction set is crucial in its use. The benefit is that it allows for applications to be produced at a fraction of the code size. This will allow ample time to focus on features that are more prevalent. The main goal of this project is to save energy; therefore, choosing an efficient microcontroller is the priority. For that, two required features of such device are high performance for precise measurements and low power consumption will helps to extend battery life. This microcontroller will be the “brain” of the project because it will control every component of the circuit; meaning that the control of the whole system will be performed by an embedded system using a microcontroller, which will be programmed to obtain all the required information and process it accordingly.

Moreover, this project will also rely on wireless communication to obtain the required information from the different components of the circuit. Therefore, wireless compatibility is another desired feature of the chosen microcontroller as well as having a decent amount of peripherals in order to be able to connect as many components as needed without using extra equipment. It will use a terminal system in order to be able to communicate with the other devices communicating with it. In addition to the microcontroller used as the “brain” of the project, another microcontroller needs to be implemented in order to measure the power being consumed by the specified appliances. The function of this microcontroller is to obtain the data needed to calculate the power currently being used by each one of the appliances. The microcontroller design will help this project in that it is small for portability, and there are many resources in order for it to work. Plus, the learning aspect

for our group is a plus as well in order to become more familiar with how bigger embedded systems help to big businesses to run their facilities and still be able to contribute to conserving power and being technologically economic.

3.2.6.1 Microcontroller Families

There are several types of microcontrollers in the industry nowadays. They are divided according to their main features such as memory capacity, architecture, bits and instruction sets, among others. There are also many microcontroller manufacturers; however, among the most popular ones are Atmel, Freescale Semiconductor, Intel Corporation, Microchip, Silicon Labs, and Texas Instruments. Atmel manufactures some popular microcontrollers like the 8051, AT91 ARM7, and AVR. AVR is one of the most popular amongst the Atmel followers. Featuring low power consumption, high performance and an 8-bit/32-bit CPU which offers flexibility to the programmer, this microcontroller has gain its own fan base. In addition to this, development tools can be found at a very low cost or even free. It has the option to use a high level language such as C or assembly language to be programmed. Some of the development tools that can be obtained are the AVRISP and AVRISP mkII, AVR Dragon, AVR ONE!, AVR Butterfly, and AT90USBKey. Furthermore, Atmel developed a new variant of the AVR, which is called megaAVR which has enhanced features such as program and data memories with performance up to 20 MIPS and a reduction in power consumption by implementing innovative technology. Due to this enhancements, this device is IoT (Internet of Things) ready. Since this microcontroller is so popular, finding helpful hints and tips is easy. The Intel 8051 or MCS-51 was introduced in 1980; however, Intel has been upgrading its architecture and improvements were made with the MCS-251; some of the changes made were: the power consumption was reduced, a new core design was incorporated and the accumulator based processor was substituted by a register based one. Moreover, another upgrade has been introduced with the MCS-151 microcontroller. The latest is designed based on the customer demand of having good products at more affordable prices, in reference to the MCS-251. Even though this is a popular microcontroller, Intel itself has no helpful information of it on its webpage. This is due to the fact that Intel is mainly an industrial company, and there are no resources or development tools that can be used for students or people who wish to work on smaller electronic projects that require the use of microcontrollers.

Freescale Semiconductors earliest microcontroller was the Motorola 6800 which was an 8-bit processor which contained serial and parallel interface, ICs, RAM, ROM and other features. It was significant in its design because of the fact that it was able to utilize one five-volt voltage source which was rare among devices since low power consumption was not a huge concern. The company continued to expand its micro technologies going to a 16-bit to 32-bit embedded systems. The M-CORE is designed specifically for low power features. It's a 32-bit MCU that includes interrupt features and utilizes a RISC architecture for coding efficiency. Its low power usage is a big plus as energy conservation is very prevalent in this day and age. The MMC2003 for example runs on supply voltage between 1.8 to 3.6 volts which is a good amount of voltage. Microchip microcontroller makes the PIC controllers which comes in 8-bit, 16-bit, and 32-bit architectures. At first many of their embedded systems had only read-only memory functionality at the time. Now their newer products feature flash memory capability in which helps to store data quicker and can be manipulated when needed. The PIC architecture is designed based on the Harvard architecture in which permits storage to be separated from signals. These microcontrollers apply

to many categories such as power monitoring, battery management and low power. These microcontrollers are programmable in the C and free for sixty-day usage. It can also extend to Basic, Pascal programming languages as well since they are easy to learn. Silicon Labs features an energy friendly microcontroller. Its products not only focus on developments for consumer, industrial tools but also Internet of Things infrastructure. They were able to start the pathway of clock generators during the early 2000s for high speed systems. As most companies start out, they had an 8-bit microchip, but high-speed implementation. The most recent microcontroller is the EFM32 32-bit MCU. According to Silicon Labs website, this particular device family focuses on ultra-low power applications, energy friendly peripherals and functional low power systems. Texas Instruments is one most popular when it comes to development boards and MCUs. Their most familiar microcontroller families are the MSP430. The MSP430 series is very a popular item that many students and small companies use for development. Its many features include being very low cost, sometimes running from ten dollars and up. Consumes very little power for efficiency and extends the life the microcontroller and is 16-bit which most embedded applications use. This type of board can be aligned with IEEE 21451.1 standard which talks more about defining an object model with an interface for connecting processors to different components such as networks or sensors. Hence, this standard is related to our project since the purpose of the microcontroller is to be the brain of the system by being connected to other components.

Furthermore, as any computer or automobile company makes different models for different purposes, the abundant availability of microcontroller options helps this group to be able to consider what MCU to use properly. As this will be discussed later, the microcontroller chosen will be used from Texas Instrument since the group is more familiar with the company and how they operate. They provide data sheets and instruction manuals free for students to use for development and experimentation. Based on the goal of the S.H.A.P.E.R project which is low power consumption, high performance and efficient use of resources, the low cost MCUS that Texas Instruments provide will be very applicable to this group's success in producing the S.H.A.P.E.R. product effectively.

3.2.7 LCD Screen

Liquid-crystal displays (LCD) are different types of visual displays for electronic devices. They work directly with the light modulating properties from liquid crystals arrayed in front of a backlight. Also, allow the user to display content that can be presented in the form of digits, letters or different variations of patterns (Computer monitors, television and 7-segment displays, for example). Among the advantages of LCD screens in modern devices, it is known that the power consumption is very low, reason why it is widely used in different types of electronic devices that can simply be battery powered. This greatly extends the mobility to a whole new level since the user doesn't have to be necessarily next to a wall plug in order for him/her to use the device. Additionally, LCD screens can produce images with a very good amount of brightness depending on the application that they are being used for, which also makes them brightness-adjustable. Because they consume very low amounts of power they produce much lower electromagnetic fields compared to one of its predecessor the cathode ray tube (CTR) screen. Not only that, but also the fact that distortion is hardly seen at the native resolution and the image is very sharp unless adjustments are made outside of the native resolution. It frees around 40% of the physical space the CTR would take because of how thin and compact this type of screen is. On the other hand the

aspect ratio is limited and it is not very effective when producing black colors or a dark scale of gray which also sets the adjustment level of the contrast to low standards. When it comes to motion, if there is a particular image that is moving rapidly a degradation in the response time can be observed. Also, if the screen is observed from a certain angle the user might notice a change in the colors and a degradation in the picture quality which also limits the viewing angle for this type of screen. This type of displays are also known for sometimes having dead pixels in some defective devices and there is no way to replace them or repair them, hence once a pixel is dead or always on it will remain in this condition forever, which forces the user replace it. Furthermore, the current battery-powered devices usually screens with a plethora of pixels in them, and hence they have big screens which requires a higher amount of battery consumption, this is one of the biggest problems that technology is facing nowadays since the battery size cannot be physically bigger than the LCD of the device itself without compromising its ergonomics. Also high brightness screens can potentially be harmful for the users and cause vision problems. Please refer to IEEE 1789 to learn further about high-brightness displays and the recommended practices to modulate current for mitigating health risks to viewers. As explained above, this type of displays have definitely revolutionized the world of electronics because of the freedom it provides when it comes to the mobility the user can achieve. Depending on the application the user can use different types of LCD screens, for advanced operations such as a smartphone a more innovative type of display would be needed. However, for the purposes of S.H.A.P.E.R. a basic one should be enough because it could be used to display something simple such as the amount of power consumed. For bigger tasks such as displaying the user's power consumption habits a more type of advanced would be needed, luckily these are already integrated in smart-phones or tablets, hence this could be displayed through an app in one of these type of devices. Figure 3 shows an LCD module that has built-in fonts and can be used to display text by sending commands to the display controller. This approach is convenient because of its simplicity and low cost, something like this can be utilized to display the amount of power being utilized in the system.

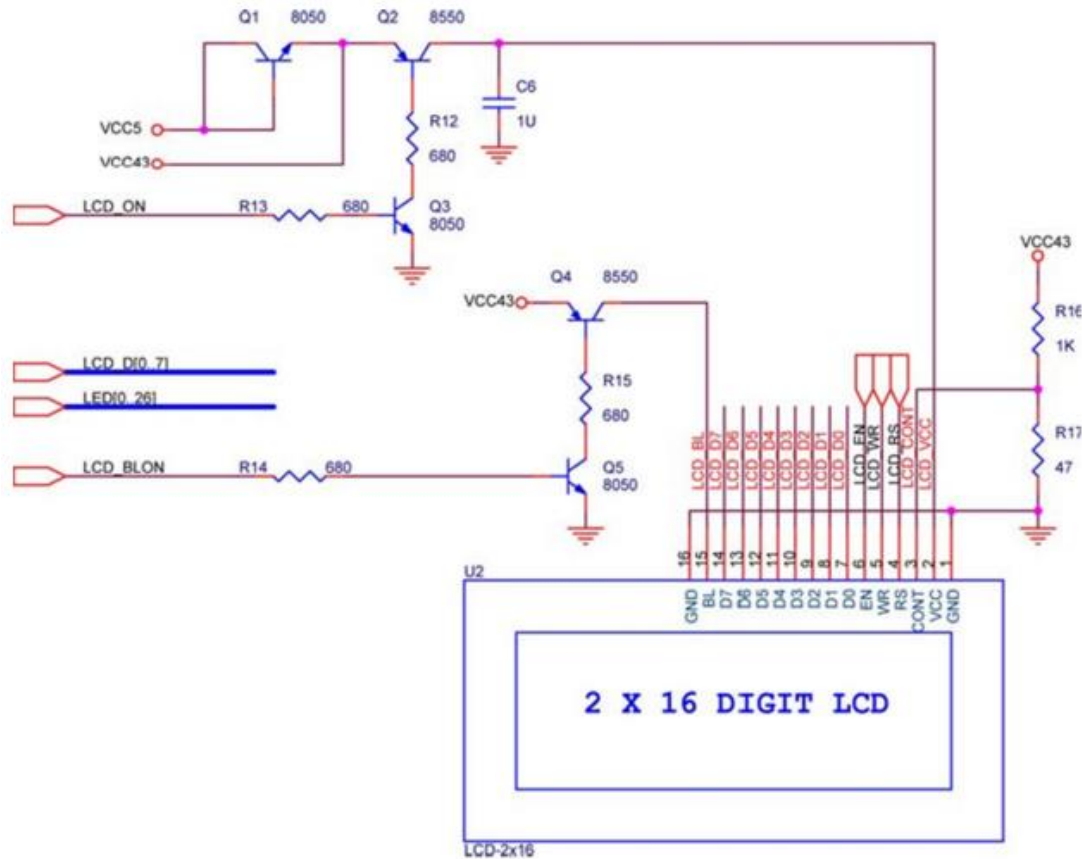

Figure 3: Diagram of a Simple LCD Module [4]
 (Reprinted with Permission of professor John S. Loomis from the University of Dayton)

3.2.8 Power Inverter

Power inverters are devices used to transform direct current DC to alternating current (AC). The input voltage for this type of device depends on the environment that is going to be associated with. Which allows to use inverters for multiple applications such as energy systems, solar panels, electric vehicle battery packs, etc. The output is commonly modeled to be a sinusoidal or square waveform, but it can also produce other types of waves. In addition, the output is meant to have a standard power line frequency of 50 to 60 Hz, a voltage the same as the DC input (Normally around 120 – 240VAC) and the power found in regular items in the market ranges from 150 to 3000W). Typically, a simple power inverter consists of a transformer, a couple of transistors along with resistors, inductors, resistors and a DC power source. Both transformer and capacitor oscillate for a certain time when current suddenly flows through them. The current comes from the DC power source and flows through both of the transistors. Once the current flows through the transformer, capacitor and one of the transistors respectively it generates either the first half cycle of the sinusoidal waveform. When the current flows again in an opposite path through transformer, capacitor and the other transistor the remaining half cycle of the sinusoidal is generated. The oscillation of this circuit is retransmitted using secondary winding of the transformer to ensure that only one transistor is being used at a time while the other one waits for the next half cycle to be created. For the advantages of using this type of device, it is known that in case that one component

of your whole system fails it will not have an effect in the performance of the remaining ones by eliminating reliability on the weakest link. Also, inverters use maximum power point tracker (MPPT) which ideally changes the voltage requirement for each component in the system. There are a large amount of sizes with different specifications designed for each particular project the user is working on. Sometimes the voltage of the wires linking an inverter can reach as high as 600V, this type of device operates at a safer voltage range of up to 240V. However, this devices can be very expensive with a price of over \$100 per unit and require maintenance if the user wants to get a good product life tune out of this device. Additionally, even if not dealing with 600V it is dangerous to deal with voltages of 120V and 240V to the point where it can be life-threatening if the right safety procedures are not considered. For this project, a power inverter is needed because as a goal we are trying to stay away from plugging the device to a wall plug and instead connected to a power supply we could carry around, such as a lead acid battery. IEEE 1184 talks about the guide for the selection and sizing of batteries for uninterruptible power systems. This type of power source is DC power, reason why the power inverter is needed to transform this into AC power since that's what appliances use to power up. Hence, through this type of device we would be able to power all of our system no matter what its location is. As it can be seen in Figure 4 a simple power inverter has the key characteristics mentioned above consisting most importantly of a transformer, capacitor and a couple of transistors to create both half cycle for the sinusoidal waveform.

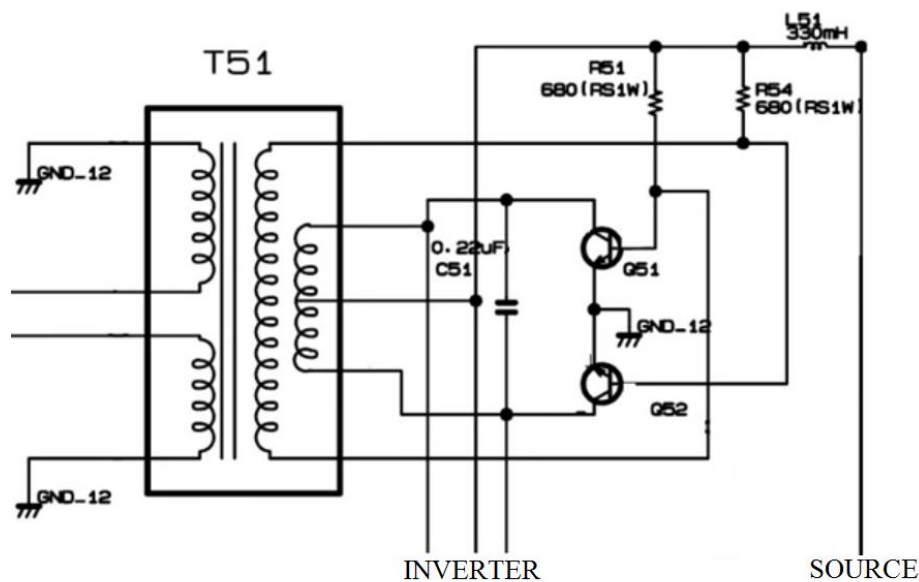

Figure 4: Diagram for a Simple Power Inverter [5]

3.2.9 Light Bulb Dimmer

Dimmers are devices that are used to control the brightness of a light bulb by increasing or decreasing it. The way the amount of light is controlled is by changing the waveform produced by alternating the voltage that is being applied to the light bulb. Generally, dimmers can be found in homes and businesses buildings and sometimes they are combined along with a light switch in one device two serve the most basic needs for this type of application. Among the most popular types

of dimmers, rheostat dimmers, autotransformer dimmers and solid-state dimmers are the most relevant ones for our research.

Beginning with rheostat dimmers which as their name states they are based on a rheostat to regulate the resistance in the circuit, which gets the job done but it makes them inefficient since a big amount of power is being lost in the form of heat and require a lot of ventilation. The load used would have to be match carefully to make the rheostat to work and since there are mechanical components in the making of the device, it can be challenging to control and slow to react. Secondly, some years after autotransformers dimmers were introduces in the market as an alternative. Even though the size factor was comparable to rheostat dimmers they provided more efficiency to the user in both voltage output and dimming effect since these were not as dependent to the load being applied to the system. Although this device was a better alternative the size factor and its limitation in dependence for slow motor drives to control the brightness is still not enough to satisfy the needs of a user that is looking to implement this type of technology in their house or company. Hence, solid-state dimers were born.

These type of devices are based in a semiconductor foundation to solve the majority of the problems that were taking place the rheostat dimmers. By using this type of technology instead of the system consuming power, it simply switches which produces large power savings and causes switching almost right away. This configuration also gives more flexibility for utilization in different areas such as in conjunction with a light switch in a building as stated before or in remote controlling. However, this type of configuration produces heat during switching and can cause radio-frequency interference with other devices in the surrounding environment. Due to its convenience of use because of how portable it is, because of the energy efficiency characteristics and its price compared to similar options, a solid state dimmer could definitely be the way to go. The reason why this could be a great alternative is because one of the main goals of S.H.A.P.E.R. is to reduce the power consumption in the user's home as much as possible, by us using a different alternative will not only be compromising our budget but also one of our main goals for this project. The purpose of using this type of device is to make sure that no unnecessary power is being wasted when the user enters the room. In a little bit more of detail, by using ambient light sensors it would be possible to determine if it is daytime or night time and by using occupancy sensors it would be possible to dictate if someone is in the room or not. As a reference, ISO 8596 standard specifies a range of methods for measuring distance visual acuity under daylight conditions, which would be helpful to determine the right amount of brightness for the user's comfort in this type of scenario. By combining all of these conditions we could create different lighting scenarios to be used in the user's home. This means that if the user is in the room but it is daytime, the amount of light being needed wouldn't be the same as if it was nighttime. Hence, this device can help control that brightness intensity in the room by making sure that by doing so not much power is being utilized. Figure 5 shows a silicon-controlled rectifier based light dimmer which utilizes phase control for light dimming purposes. It has a bridge form a diodes D2, D3, D4 and D5 to generated pulsed DC. As the voltage increases C1 charges up, once it allows D6 to conduct, D6 injects current into the SCR, allowing it to conduct. Then D1 discharges C1 using the SCR. Once there is no current remaining in the circuit, the SCR will turn off at the end of the half cycle, then it stars for the next half cycle to go through the process again.

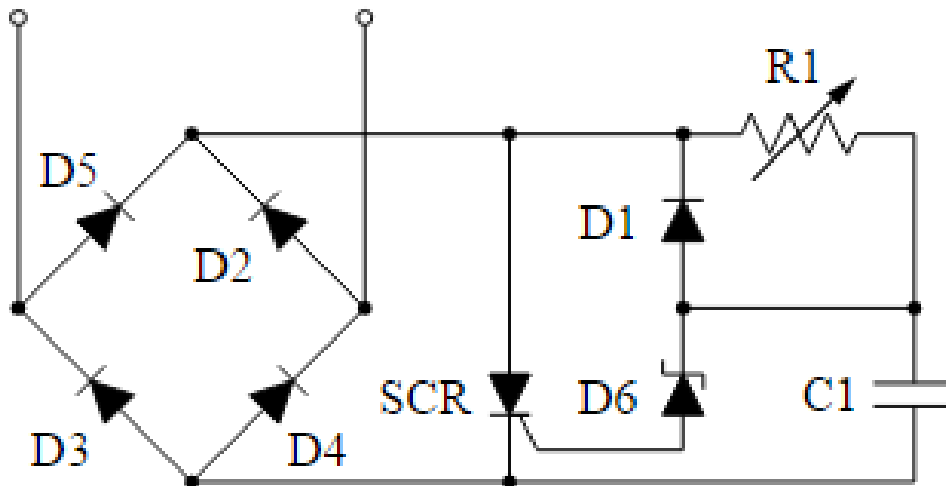

Figure 5: Diagram for a basic SCR Dimmer [6]

3.3 Strategic Components

The components of S.H.A.P.E.R. is to provide an automated system in which regulates a user's light usage and power usage that is specifically AC. With the previous research already mentioned, the main components that will allow this system to run effectively is the light sensors. They are critical based on their design to regulate light levels dependent upon user preference and external sources. The main advantage of this system is that it utilizes low cost components which run on low power sources, thus giving the user a more efficient system. When combining the use of ambient and occupancy sensors, the system takes into account how many people are in a specified location and can determine when light needs to be on or off. The ambient light sensor specifically aids in automatic lighting regulation and takes into account outside light as well to dim the light to a specified amount of lux (the amount of brightness). The dimmable light system will utilize fluorescent or LED bulbs in order to provide sufficient power conservation. The use of these items is critical in achieving our goal in cheap, low power but very efficient lighting system for the user. LED lighting has become very popular in the lighting industry. They are usually cheaper, easy to replace and provide a lot more brightness. But for simplicity of this project, fluorescent bulbs will be utilized since a sufficient amount of LEDs will have to be purchased to provide enough light. Power monitoring technologies will also be implemented in order to make this system applicable to the user's needs. In order for this to work, an appliance will be utilized, for example a water heater, to be used for collecting data on its voltage and current usage. This system can be simulated with tub of water for simplicity. The air conditioning system will be simulated using a fan or vent for demonstration purposes. Again, the air conditioning system will be controlled by the microcontroller and be programmed to preset conditions depending unless the user changes those settings for personal preference is more convenient than the preset conditions. The AC system was chosen since this can be a huge power user in houses. Normally AC usage sends electrical bills up soaring into over 200 dollars per month on average for families. For proper energy conservation, in the hottest months of the year, the microcontroller will set the AC system at a temperature that is still comfortable for the user and not using a lot of electricity which is usually around the 75-80-degree range. This will be accomplished by using a thermostat so the microcontroller can gain access to the thermostat via Bluetooth and the user can change settings manually for his/her use.

Again, the purpose of this project takes into account power systems that the user uses consistently and based on that the system is focusing on critical components of the home.

The project would not be workable if there was no power source. Realistically, a home already has access to electrical power from a user's power company. But for the purposes of this project, the power sources that will be considered for this system is batteries. This will serve as an independent power source so as to not rely on external sources that could potentially fail. Power relay systems or switches can also be implemented for this system. This will allow the flow of current to be regulated based on the usage of an item. In contrast to the lead acid battery, the relay can act as a safety mechanism if for some reason too much current is flowing through the system, the relay can terminate the connection between devices and stop any more current from flowing which will save the device from being short circuited. For the user's convenience, the utilization of an application that is compatible with a user's smartphone whether iOS or android operating system will be used to control the user's lighting and AC system and also provide power usage information to the user as well. This is a bonus feature if you will since the phone will need a strong API in order to communicate with the home's power monitoring system and through that the systems need to be able to communicate through the system as well for complete reliability. But what is strategic about this application is that it can allow the user to always be aware of their power usage and can control it when they are away or prepare the environment to their preference as desired. Since android is more prevalent among phone usage and there are open source development tools, it will be beneficial to create this app in this operating system. It is also beneficial to the user because power consumption is not always on the user's mind since they do not see the underlying components that help it work and how much they pay wattage per hour. For the android app, java will be used to program the user interface for the smart phone since there are IDEs such as Eclipse, NetBeans, and others that have example projects that can help with the communication protocols between the microcontroller and the subsystems.

As discussed earlier, both Wi-Fi and Bluetooth can be used to allow the microcontroller to collect and send data between all the subsystems and the app can use this implementation as well. Bluetooth will be utilized in this project more so since it is better suited for IoT (Internet of Things) devices which means that devices are all communicate via internet or data without or minimal human interaction. The Bluetooth will serve as a communication pathway for the systems and will not need to use of a router or wire. Bluetooth only requires the systems to be in close proximity of each other in order for the subsystems to effectively communicate and pair with each other. This is advantage for the home user in that in case Wi-Fi provided from the router goes out, their system can still operate. Again, the project is to help the user not make it any more difficult and the user will not have to setup Bluetooth since the device will already possess that feature, the user would just have to active the Bluetooth option for their phone, but the microcontroller will already possess that implementation. Lastly, the main part of this project is the microcontroller itself. The microcontroller was chosen as the central piece of equipment since it already has features to help in this project. It is able to use terminal programs to be able to program certain functions in order to communicate with the subsystems. The microcontroller is fairly cheap in price and mainly used for developmental purposes. The data sheet and instructions to utilize is provided and low powered as well. The memory in the microcontroller will be used as a storage database if you will to hold the program in order to retrieve and send data to the subsystems.

The design of the project is crucial in that all systems work together at a cost that is feasible for the user. With this design implemented strategically, the user can benefit from this system

3.4 Possible Architectures and Related Diagrams

In this section a set of diagrams and a sketch can be found. The function of these is to provide a possible foundation of how the S.H.A.P.E.R. is going to work based on the research done from the sections above.

3.4.1 Block Diagrams

This section is divided in four different diagrams that provide a basic understanding of our expectations for this project. It is divided in system input / output, appliance(s), occupancy & ambient light, application software control and energy monitoring system processes flowcharts.

3.4.1.1 System Input / Output Workflow

The flowchart shown below in Figure 6 explains the basic functionality of S.H.A.P.E.R. considering physical presence, sun light, as an input and dimmable light, controlled, the LCD screen and the Android app as outputs of the system.

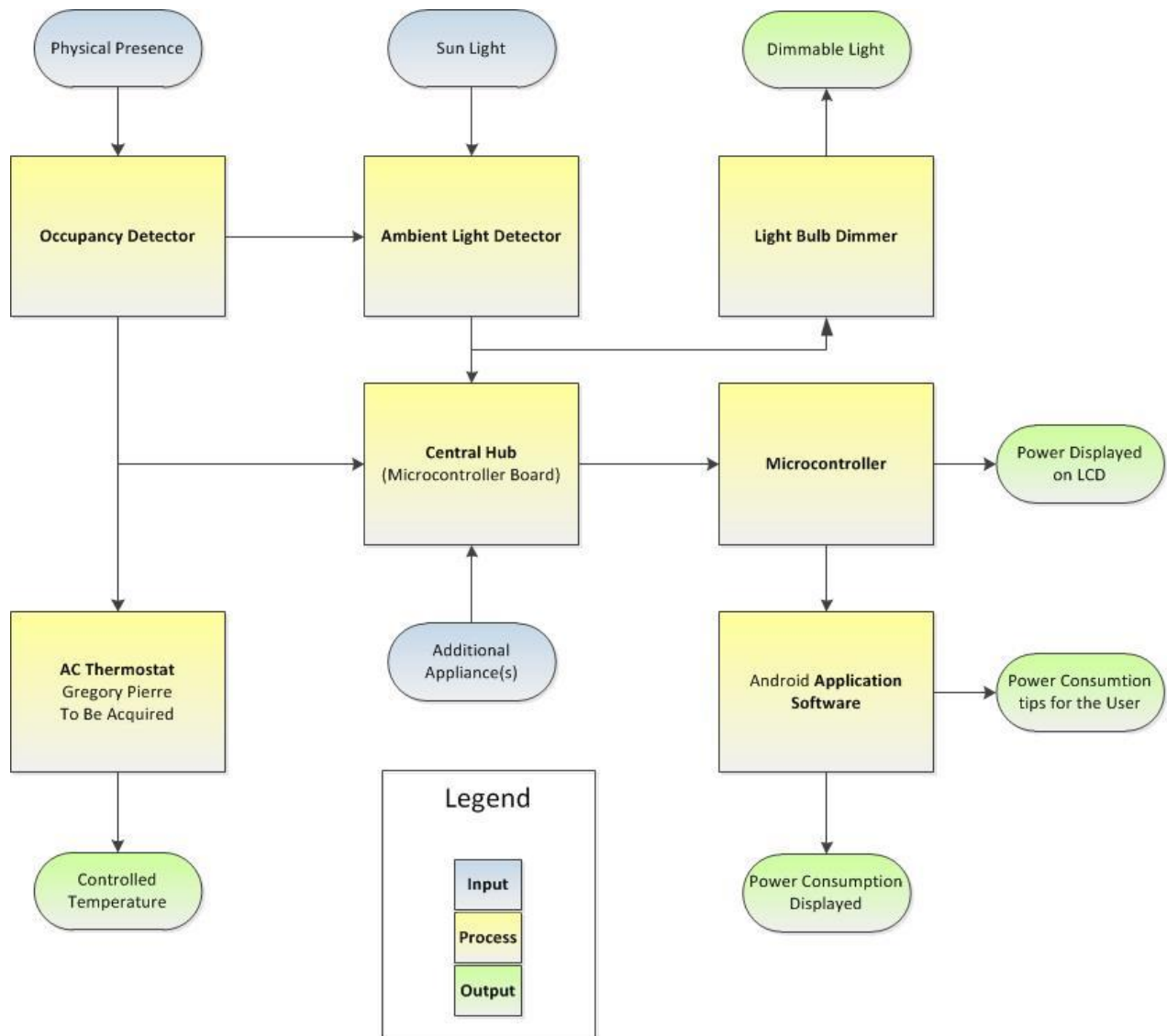

Figure 6: System Input / Output Workflow

3.4.1.2 Occupancy & Ambient Light Sensor Process

The flowchart in Figure 7 shows how the system works in regards to the occupancy and ambient light sensors. The system first checks if there is someone in the room, if there is someone then the AC thermostat drops to a user’s preferred temperature and then the ambient light sensor checks if it is daytime. If it is daytime then the dimmer sets the light bulbs to the maximum preset brightness, if not then to the minimum preset option. Moreover if someone leaves the room the light turns on and the AC thermostat gets preset to at least 78 °F (a temperature where the AC wouldn’t consume too much power).

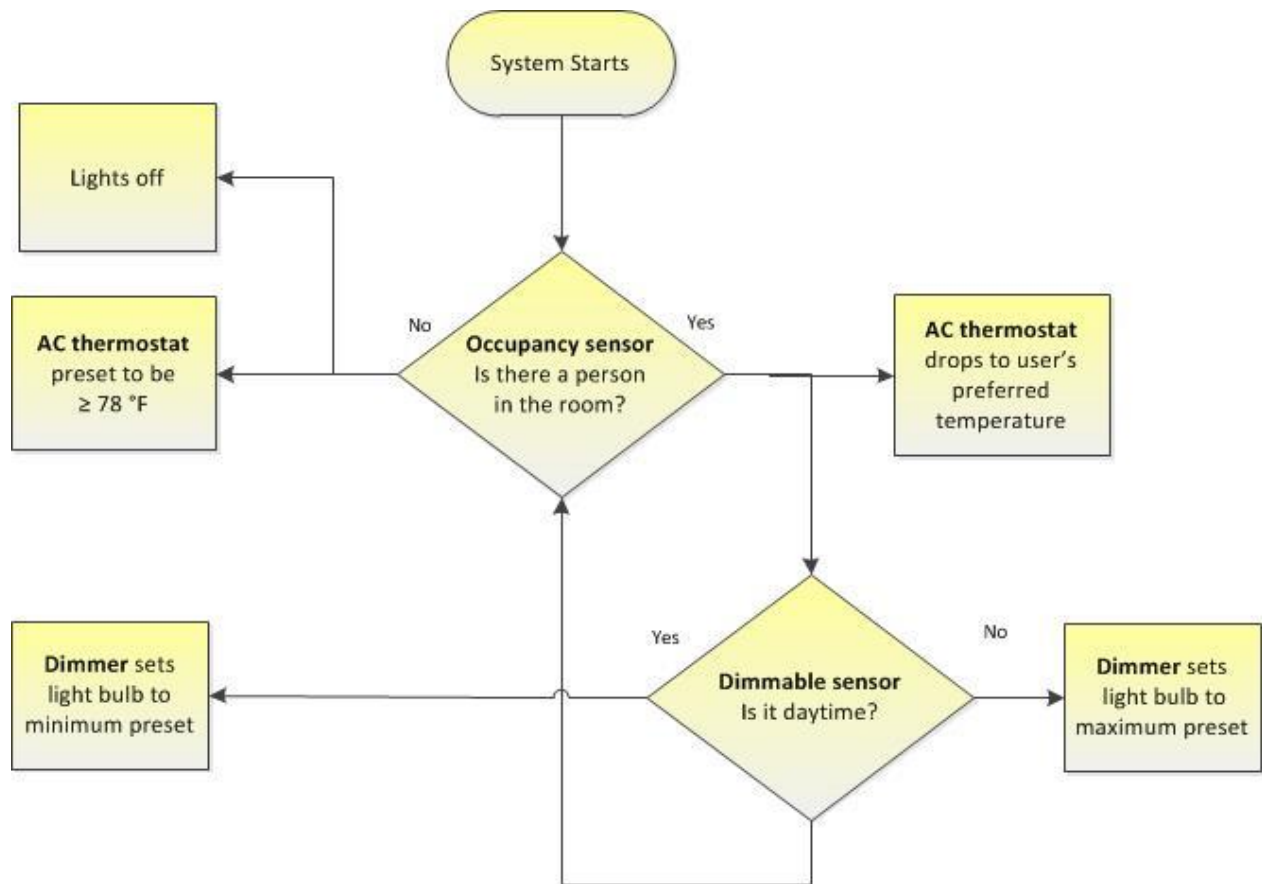

Figure 7: Occupancy & Ambient Light Sensor Process.

3.4.1.3 Application Software Control Process

The application software control process flowchart in Figure 8 is designed to explain how the application that is going to be developed to control the system can be utilized. First, the system checks if the request is for an AC-related task. If it is then the user can change the minimum and maximum preset scenarios for the AC. Otherwise, if it is a task that is related to the control of the light bulbs then it allows the user to turn on/off the light bulb and manage the brightness. In addition it obtains power for all of the connected appliances and allows the user to view his/her power consumption along with some smart tips to save money.

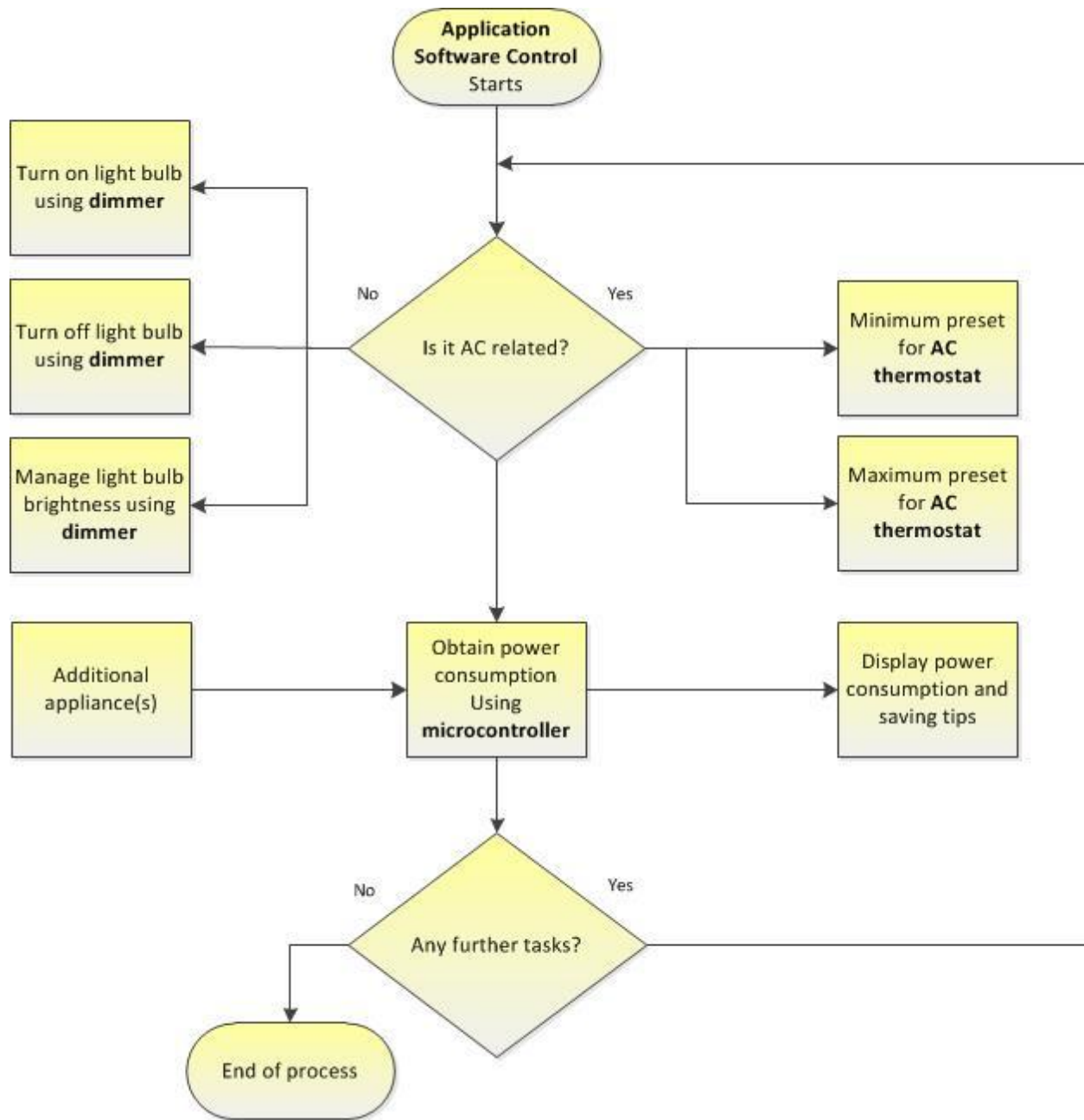

Figure 8: Application Software Control Process

3.4.1.4 Energy Monitoring System Process

Finally this flowchart in Figure 9 goes in more detail in regards to the energy monitoring system process. First the system analyzes the power obtained from the appliances, the power is displayed and compares to see if the power usage is above or below the maximum allowed value. If it is then it displays the estimated power bill and will continue obtaining input from the appliances. If not, then it displays a warning message along with the recommendations and tips to create habits to save money and continue the process that was described above.

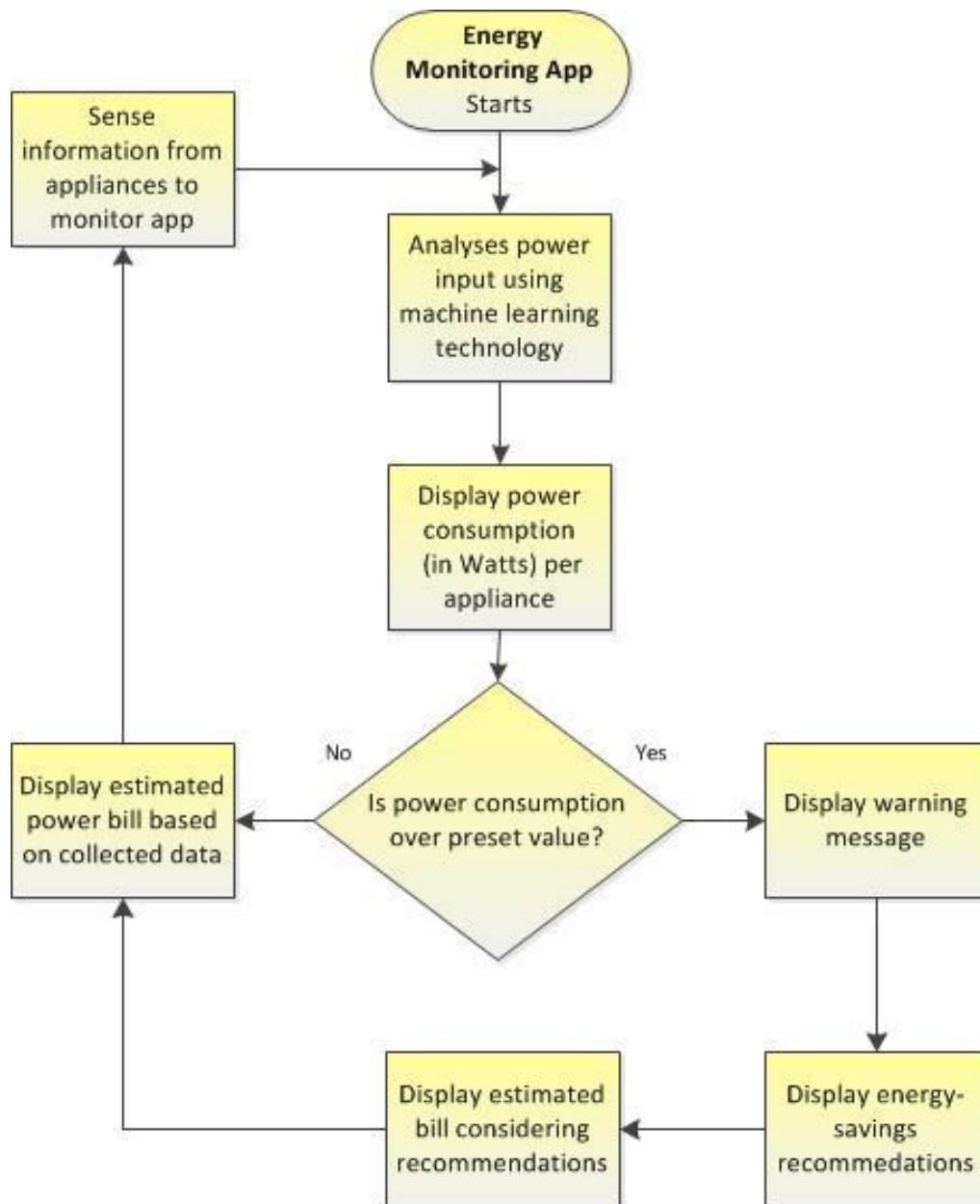

Figure 9: Energy Monitoring System Process

3.4.2 Devices/ Elements Interface Sketch

The Following sketch shown in Figure 10 provides a better representation on what the system is going to be connected based on the information researched. As it can be seen the red line shows the power flow path and the blue one the data flow path. The system begins with the lead acid battery being the source of power. Since it provides DC power, a power inverted is needed to convert this to AC power, then this power is given to the microcontroller and to a current collector which is going to be in charge for distributing the power the appliances and for obtaining the current and voltage being consumed by the thermostat, an additional appliance, the dimmer and

the light bulb. Moreover, the LCD screen, the occupancy sensor and the ambient light sensor are connected to the microcontroller to obtain part of the input. The other part of the input is the power consumption from the appliances that is sent to the microcontroller with the current collector. As expected, once the microcontroller obtains all of the inputs it is responsible for getting the outputs. Hence it connects directly to the thermostat, the dimmer and the LCD display via a wired connection and with the android app via Bluetooth.



Figure 10: Device / Elements Interface Sketch

4.0 Related Standards and Constrains

In this section the different standards related to the research made for S.H.A.P.E.R. are going to be identified in tables. In addition, there is another section that contains the realistic design constrains to consider in order to make our project feasible, effective and efficient.

4.1 Design Impact of Relevant Standards

As stated above, here the different standards considered for the research are mentioned and categorized by the device, type, standard name and a description. The standards were divided in

tables for power monitoring, wireless network communication, electronic power supply, occupancy sensors, ambient light sensors, operating system compatibility, microcontroller, LCD screen, power inverter and light bulb dimmer

4.1.1 Table of Power Monitoring and Wireless Network Communication Standards

The following table has some of the standards considered for this project in regards to the power monitoring, wireless network communication. Moreover, the standard name has been seen in addition to a brief description of how this standard is relevant.

Table 2: Power Monitoring and Wireless Network Communication Standards

Device / Function	Type	Standard Name	Description
Estimated Appliance Operating Cost List According	Power Monitoring	IEEE 1159	Recommended Practice for Monitoring Electric Power Quality.
Power Monitoring Options	Power Monitoring	IEEE 1851	Standard for design criteria of integrated sensor-based test application for household appliances.
Analysis of Data	Power Monitoring	IEEE 1621	Standard for the user interface for the power status control of electronics for work and home environments.
Wi-Fi	Wireless Networks and Communication	IEEE 802.11	MAC and PHY specifications for implementing WLANs in the 3.6 and, 5 and 60 GHz.
Bluetooth	Wireless Networks and Communication	IEEE 802.15.1	Standard for data transmission for short distances. UHF radio waves from 2.4 to 2.485 GHz
Near Field Communication (NFC)	Wireless Networks and Communication	IEEE 802.2	Standard to support small applications with limited data transport requirements.

4.1.2 Table of Occupancy Sensors and Ambient Light Sensor Standards

To add up to the table above the S.H.A.P.E.R. team has also created a table of standards with a brief description of their purpose for the occupancy sensors and ambient light sensors that were considered for the project.

Table 3: Occupancy Sensors and Ambient Light Sensor Standards

Device / Function	Type	Standard Name	Description
Ultrasonic Sensor	Occupancy Sensor	IEEE C62.41.1	Guide on the Surge Environment in Low-Voltage AC Power Circuits.
Passive Infrared (PIR) Sensor	Occupancy Sensor	IEEE 2700	Standard for framework used in sensor performance specification terminology, units, conditions and limits. Commonly used for humidity, temperature, ambient light and proximity sensors.
Software Using Surveillance Cameras	Occupancy Sensor	IEEE 1900.6	Standard for Spectrum Sensing Interfaces and Data Structures for Dynamic Spectrum Access and other Advanced Radio Communication Systems.
Microwave Sensor	Occupancy Sensor	IEEE 1851	Standard for design criteria of integrated sensor-based test application for household appliances.
Photo Resistor	Ambient Light Sensor	IEEE 2700	Standard for framework used in sensor performance specification terminology, units, conditions and limits. Commonly used for humidity, temperature, ambient light and proximity sensors.
Photo Diode	Ambient Light Sensor	IEEE 255	Standard that provides a uniform system of letter symbols for electrical quantities and parameters as applied to semiconductor devices.
Photo Transistor	Ambient Light Sensor	IEEE 218	Standard methods of testing transistors.

4.1.3 Table of Operating System Compatibility Standards

So far, the table of standards shown above have introduced the majority of the hardware that was researched. Nevertheless, in this table goes is more related to the operating systems standards along with the description.

Table 4: Operating System Compatibility Standards

Device / Function	Type	Standard Name	Description
Mac OS	Operating System Compatibility	IEEE 1680.1	Standard that describes set of environmental performance criteria for the design of personal computer products in order to reduce the environmental impact of electronic products.
iOS	Operating System Compatibility	IEEE 1003.1	Portable Operating System Interface. Defines a standard operating system interface and environment. Includes general terms, concepts, interfaces and conventions.
Android OS	Operating System Compatibility	IEEE 1003.1	Portable Operating System Interface. Defines a standard operating system interface and environment. Includes general terms, concepts, interfaces and conventions.
Windows OS	Operating System Compatibility	IEEE 1680.1	Standard that describes set of environmental performance criteria for the design of personal computer products in order to reduce the environmental impact of electronic products.
Windows Phone OS	Operating System Compatibility	IEEE 1003.1	Portable Operating System Interface. Defines a standard operating system interface and environment. Includes general terms, concepts, interfaces and conventions.

4.1.4 Table of Electronics Power Supply, Microcontroller, LCD Screen, Power Inverter and Light Bulb Dimmer Standards

Finally, for S.H.A.P.E.R. we considered extra components that are going to be needed in order to make the system work as expected. Hence, the related standards for the electronics power supply, microcontroller, LCD screen, power inverter and light bulb dimmer can be found below.

Table 5: Electronics Power Supply, Microcontroller, LCD Screen, Power Inverter and Light Bulb Dimmer Standards

Device / Function	Type	Standard Name	Description
Lead Acid Battery	Electronics Power Supply	IEEE 1187	Recommended practice for Installation Design and Installation of Lead Acid Batteries.
PowerSwitch Tail II	Electronics Power Supply	IEEE C37.233	Guide for Power System Protection Testing.
Relay	Electronics Power Supply	IEEE C37.90	Standard for Relays and Relays Systems Associated with Electric Power Apparatus.
Microcontroller	-	IEEE 21451.1	Defines an object model with a network-neutral interface for connecting processors to communication networks, sensors and actuators.
LCD Screen	-	IEEE 1789	Recommended practices for modulating current in high-brightness displays for mitigating health risks to viewers.
Power Inverter	-	IEEE 1184	Guide for the selection and sizing of batteries for uninterruptible power systems.
Light Bulb Dimmer	-	ISO 8596	Specifies a range of methods for measuring distance visual acuity under daylight conditions.

4.2 Realistic Design Constraints

The constraints presented in this section are realistic and related to our project. Moreover, most of the following constraints were taken into consideration in order to make our design as simple as possible and feasible while, at the same time, the final product is effective and efficient.

4.2.1 Economic and Time constraints

The main constraints that every engineer faces are those related to economic and time issues. In our case, we will build a home automated system that needs different sections in order to work properly. Each section will have its own components; therefore, the cost of the project can be really high. Even though one of our main objectives is to minimize the design complexity in order to reduce cost, there are still a lot of parts that we must buy in order to complete the project; hence, a budget needs to be estimated in order to reduce costs and obtain the most efficient components, especially if you take into account that the cost is mainly out-of-pocket expenses split equally among each member of the team. Applying for funding and sponsorship is a good way to relief a little bit the cost constraint; however, it is up to the sponsors to approve your proposal. Once the budget is estimated, the design and implementation of the project gets to be easier because the

resources needed to develop the task can be obtained by price, capability, and main features comparison. In our case, we were lucky enough to obtain sponsorship, and we will have to be even more careful when it comes to deciding which elements are more suitable to be part of our design because if we can create our project cost efficiently we will be also saving our sponsors' money.

Time is a big constraint in our case since we have to design and build a project in a given amount of time while taking other classes at the same time. The overall time set up for the project can be a big problem if we do not follow the given deadlines and rules. Since we do not have infinite time to finish the project, some factors need to be taken into account at the time of planning the milestones for the design. Ordering parts online can be a huge issue since most of the inexpensive components are sold on pages like "ebay" and they come directly from China, which means that it can take up to one month to arrive to their destination. If we add to this, that the pieces can be damaged or different to the item described, it will add more time and money to fix the issue. In addition to this, shipping/delivery delays and return issues can also consume a big amount of time. Another factor is the design of the printed circuit board (PCB). Once we decide on the design of the PCB, we need to compare prices and quality of the vendors in order to get the best product. However, that takes time, because we will need the PCB to be built and the parts to be mounted on it. Even though that can be done by ourselves, it may also consume a significant amount of time, especially if our design is complex. Another factor we need to take into account is the testing process. Testing the design may take a while, particularly when our design consists of more than one section; hence, it is important to start testing the prototype way before the project due date in order to make sure that we have enough time to fix any upcoming issue and complete the task on time.

4.2.2 Environmental, Social, and Political constraints

The environmental constraints of this design are related to the consumption of energy of the same. Since we want our users to be more conscious about the energy waste in their houses, we need to take into account some aspects before building our own project. For instance, low power consumption parts need to be integrated in our design even though more sophisticated elements with higher power consumption can be purchased. In addition, we want to make sure that the use of batteries is reduced to a minimum in order to avoid the disposal of the same which also affects the environment. Our project is ambitious because in addition to make a smart home automated system, we also want to create conscious users when it comes to energy management. Therefore, it is imperative that our design itself consumes the least power possible to avoid wasting energy and therefore, fuel. Another equally important factors are temperature and humidity. Most of the parts we will use are sensitive to big changes. For example, sensors can suffer damage when exposed to high temperatures and high humidity; therefore, it is necessary to provide the required protection for these components in order to keep them working properly. Moreover, we also want to obtain the least amount of parts necessary in order to avoid throwing away some elements that can be prejudicial for the environment, which also means, that we are recycling as much as we can.

Social constraints apply for the team members of the group. The more time we spend in a laboratory or working on our project may seem to be beneficial for the overall success of the team; however, this can also affect the group's interaction. Spending a lot of time assembling the project

may create frustration; hence, communication is very important among the members of the team. The less time we occupy building our design while still learning the process and concepts, the best the learning experience and the less the frustration experienced by the group. Moreover, each person of the team has his or her own social life, which can also be a constraint to the smooth development of the project because sometimes unexpected situations occur and they are out of our hands, so if this happens, the design consolidation may be affected by external causes. Similarly, the interaction among the members of the group can also be an issue. Since we will be spending a lot of time together, tension can be created among us if a conflict arises and even though we are professionals and also friends, internal arguments can affect the dynamic of the group as a whole and as a result the communication among us which will jeopardize the effectiveness and completion of the project. Another social constraint is the position of the future users of our project. A home automated system may be more expensive when it is set up for the first time and this may act against the acceptance of some users thinking that the cost of the product is not worth it. Nevertheless, the initial cost may be more expensive, but in the long run the user will be able to reduce the power bill if he or she follows the tips we will provide. And even though some people do not care about money, it is our job to educate them about the necessity of saving energy for the good of the planet.

Political constraints also play an important role when it comes to a completion of a design. In our case, a possible constraint may be the use of a software/hardware that has been developed under public funding. Since our project is aimed to every single household in the country, we have to be careful when downloading a specific software or purchasing hardware because it may seem like we are going to use those in our advantage. Other than that, our project has no any other political constraint. On the contrary, politicians are always talking about saving energy and making the world greener, which is the main purpose of our project.

4.2.3 Ethical, Health, and Safety constraints

Ethical constraints need to be considered when creating a project. In our case, since we will receive funds from sponsors, our most important ethical responsibility is to make sure that the funds received are spent in the proper manner and to obtain exclusively what we need for the project. The money we receive cannot be used for a different purpose and we have to make sure as a team to document every single transaction that is made with the funds we obtained. Making the right decision when it comes to spending money can be an ethical constraint, in our case, however, we all are very responsible and thankful of our sponsors; therefore, our expenses will be properly documented and respected. In addition to this, appropriate usage of the parts obtained for this project are required. All of the elements we purchase will be used with the solely purpose of building our design. The moral conduct of each member of the group can also be an ethical constraint; however, in our case, we will never do anything to compromise the integrity of our group or the project. An important design detail of our project is the use of wireless devices. An ethical constraint can be the proper use of Wi-Fi capabilities since security is a major factor when it comes to Wi-Fi communications. Making sure that we use a wireless connection with the proper permission will avoid the unethical practice of invading other people's security. Moreover, our project also requires of a user friendly application, which means that we will need to take into account the copyrights of each program we considered to use in our design. The inappropriate use of the open source resources students have access to, is also an ethical constraint, especially when

most of the physical components and software products are available for students at a special rate and sometimes even for free. Using them with other purpose than complete our design would be outrageous and very unprofessional; therefore, every open source or student resources need to be utilized properly avoiding any unethical activity. Finally, our project is design to ease the life of the users by keeping track of their power consumption and taking care of their energy management; therefore, it would also be unethical to use the information obtained from the users for personal gain; all the information given by the users should stay confidential and untouchable.

Health constraints are considered mainly in the lab environment. All the proper equipment needs to be worn by every single member of our team in order to avoid intoxication or any other risk to the health. Our design itself does may have health constraints when it comes to the products obtained from a third person. Before buying any item, we need to make sure that the item acquire does not contain any hazardous material that may put in risk our health or that of the user because sometimes, the materials used when building a product are not specifically hazardous when they are first acquired, but with time, they become dangerous. We also need to take into account the appearance of the product as a constraint. We may think that a certain appearance is more appealing to a user when in reality, the product may be built with toxic materials.

Safety constraints are considered for this design, especially when it comes to work in the lab. Since we will be working with electricity, it is very important for every member of the team to be aware of whether the power supply is currently connected and on or not before handling any device that can cause an electric shock. Moreover, if we are to use high voltage components or power sources, it is indispensable to display the appropriate warning signs in order to avoid injuries. Moreover, when it comes to the purpose of our project, we also need to provide the users with a manual that will guide them on how to properly set up and make correct use of our design. The user's manual will include information regarding the functioning of the system as a whole, children's safety facts, system set up, and electrical hazards. In addition, another safety constraint include the proper usage of the app. Most people nowadays are able to understand and feel comfortable while operating a technological device; however, it is not one hundred percent of the times that this happens. Some people, who are not familiar with the most recent technologies, will be prone to make mistakes when it comes to using the app; therefore, some safety tips need to be included also in the user's manual in order to avoid breakage of the app device. We also need to be careful when it comes to mount the parts in the PCB, the proper equipment needs to be used in order to avoid injuries or even breaking the PCB or the parts. Furthermore, precautions are needed also when setting up the project in a home for the wiring of the parts and assembling of the components if not handled with the proper care, can provoke a safety disaster.

4.2.4 Manufacturability and Sustainability constraints

Manufacturability constraints include the use of the right materials needed for the project components. Our project needs dimmable light bulbs and sensors which can be very sensitive to temperature and humidity; therefore, the item descriptions need to be carefully read before purchasing any product. Another constraint is the functionality of the electronic devices which can present some defect at the time of purchased. Having defective parts delays the assembly process and hence, the testing of the design. Moreover, our project requires a printed circuit board (PCB) which needs to be manufactured at a specialized location, meaning that we will rely in a third entity

to manufacture the “heart” of our design. Having a vendor build our PCB does not guarantee that the product will be one hundred percent perfect; therefore, we must design it in a reasonable amount of time in case any defectiveness is present. In addition to having the PCB built by a vendor, we also need to mount the components into the PCB in order to create our circuit. This manufacturing process may also take some time and needs to be done in a proper way, so the project works correctly as a whole. Another constraint may be the Wi-Fi capability of our components. For our project is necessary a wireless communication in order to avoid heavy wiring and waste of energy; therefore, if the parts we aim for are have a bad Wi-Fi capability, our design may not work properly. Having an app device also gives us a constraint. Our device needs to be compatible with the desired software to be used.

Sustainability constraints include the lifespan of our design’s components. Most of our parts need to have a similar life span in order for the circuit to work properly as a whole. In addition, the durability and reliability of each element is also a constraint. Our project is designed to be able to let the user know about his or her energy consumption; therefore, having a reliable circuit is of main importance when it comes to the functionality of our home automated system. Every part needs to be tested before hand in order to make sure that it will work and that is compatible with the rest of the circuit. In addition, the project itself needs also to be reliable and durable. It needs to work properly and perform the specific tasks it was built for. It needs to provide the user with the main purpose of saving energy. Finally, even though this is a school project, a question needs to be asked: can this project survive? This is another constraint of our project. There are a lot of similar products out there that focus on saving energy and making the world a more sustainable place; therefore, if we wanted to make our product available, we will have to be able to reduce the cost of the components and the whole circuit itself in order to make it competitive. Our project can be seen first as expensive compare to the regular home systems, but once users understand that this product will help them save money and energy in the long run, they will be encouraged to acquire it.

5.0 Project Hardware and Software Design Details

The system requirement specifications and the research stages were an important part for the development of this design. Through them, we were able to better understand the real constraints and feasibility of the desired result. Moreover, it provided us with relevant information that are extremely beneficial for the next step of the design, which is to create the initial hardware and software architectures and to start looking for specific components that are going to best suit out project’s needs. In the following sections, a detailed hardware and software design details will be develop.

5.1 Initial Hardware Design Architectures and Related Diagrams

This project is a home automation system that controls several electronic devices. The initial design architecture consists on a central hub where the master microcontroller and master Bluetooth module will be placed. The MCU main function is to control the whole circuit interaction. The microcontroller will receive data from the PIR motion sensor and the ambient light motion sensor in order to determine if a person enters or leaves the room. Moreover, it will also be receiving updated information about the power consumption of the specified appliances.

The master microcontroller will process the data obtained from the sensors, and it will send a signal to two electronic devices for them to output the required information. The first device is the AC thermostat, the microcontroller will be connected as a peripheral to the master microcontroller and once the processor receives the signal that someone is in the present in a room, it will send the thermostat the instruction to change the temperature to a preset temperature given by the user. However, if the signal received by the microcontroller is that the person left the room and the room is now empty, the AC thermostat status will be changed to switch the temperature back to the previous preset value of 78 Celsius degrees in order to save energy. The second device controlled by the MCU is a dimmable lightning system, which for simplicity purposes will be a dimmable circuit connected to an LED dimmable light bulb. For this, the microcontroller will also utilize the signal obtained from the PIR sensor and also the ambient light sensor. The dimmable lightning system will have a slave microcontroller with an integrated slave Bluetooth module that will establish the connection with the main hub, where the master Bluetooth module will be. Once the main MCU determines if someone is present in the room, it will send the instruction to the dimmable lightning circuit to turn ON; however, the dimming of the bulb will be given by the input obtained from the light sensor. If the light incoming is very bright, then the bulb will be set up to its minimum brightness, and vice versa. In the case that the master MCU receives the signal that a person left the room, then it will send the instruction to the slave microcontroller to turn OFF the lights.

The master MCU will also have a second function which is to process the data obtained from the power monitoring nodes and send the signal to be displayed. The LCD will be connected also as a peripheral to the master MCU, which allows LCD connections to be done. Each of the power monitoring nodes will have a current/power monitor IC that will obtain the appliance's flowing current information and it will calculate the power been consumed by it. However, an AC/DC converter will be needed for such IC because it measures DC current, not AC. Since each node will also count with a slave microcontroller and an integrated slave Bluetooth, the power calculations from the IC will be transferred to the slave microcontroller and from there, it will be sent via Bluetooth to the main hub, where the main MCU will get the data and update the LCD display with the most current information gotten from the appliances.

Finally, the system will be powered by a lead battery. Since the battery administer DC energy, a power inverter is needed to convert the energy to AC and be able to power the electronic components of the system.

An initial design architecture of the same can be found in Figure 11:

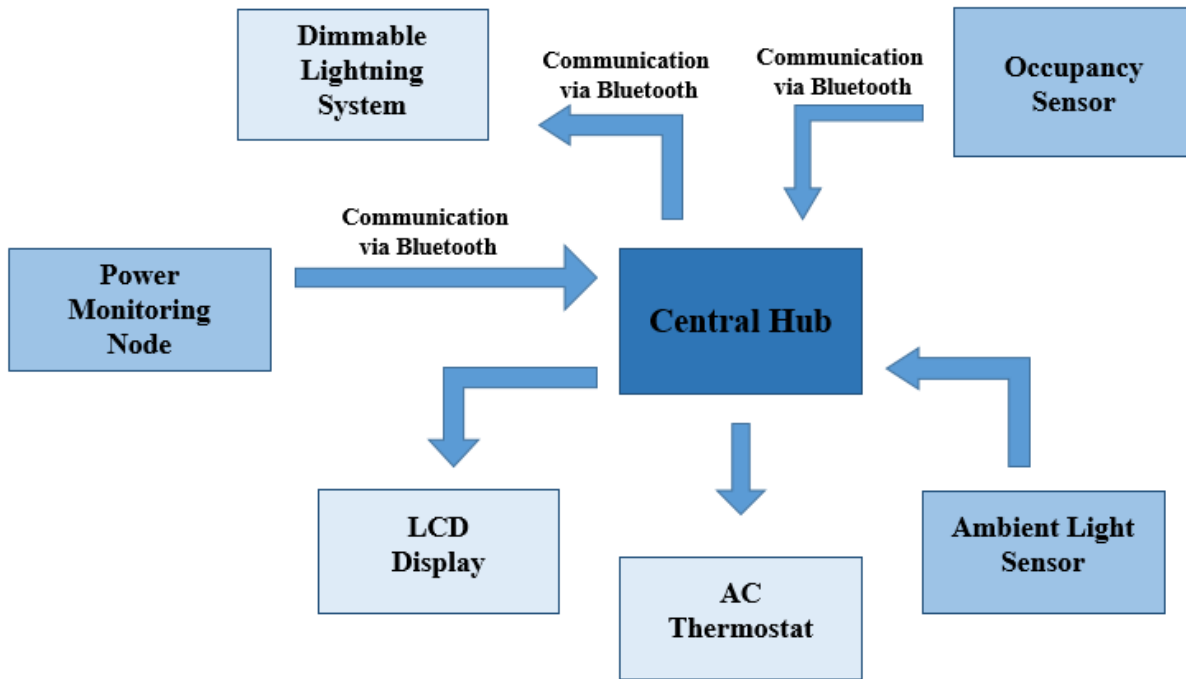

Figure 11: Diagram of Initial Hardware Diagram

5.2 Hardware Design

Since the S.H.A.P.E.R is a home automation system, its two main features are to control the lightning and air conditioning settings according to the information received from its surroundings, and to measure the power consumption of the major appliances that waste the most energy. Therefore, our project will incorporate two major hardware sections: The central house hub (1) and the power monitoring nodes (3). The central hub consists of a power supply, a microcontroller, relays, LCD, ambient light sensor, occupancy PIR sensor, dimmable light bulbs, a thermostat, and a wireless component, which will be a Bluetooth component for this project. Each power monitoring node consist of a power supply, a relay, power monitoring IC, and also a Bluetooth component.

Another important part of our design is the fact that we need a backup power supply in order to prevent the system from shutting down if the existing power supply stops working or if there is a power outage in the house. Therefore, a lead battery will be integrated also in our hardware system for it will act as the backup power supply for both: the central hub and the power monitoring nodes. Since our system will communicate wireless through a Bluetooth component, we will not experience an extra overload of wires and cables in the PCB, which will reduce the size and thickness of the same making the design more appealing to the human eye.

Another consideration to have when it comes to the hardware system is how we will set up the circuits in a house environment. The dimensions of both frames: the one holding the main hub, and the one from the power monitoring node, will be given by the size and thickness of the PCB once the components are mounted on it. Moreover, the height of the screws that will be used to

hold the board in place needs to be taken into account also. However, we want the cases for each subsystem to be as small as possible in order to make it likeable to the user. For further information on PCBs development and vendors please refer to the In addition to the previous considerations, we also need to make sure that the dimmable light bulbs that are going to be used in the project support smart dimming because we are trying to get rid of switches and we also want to make the brightness of the light bulb vary according to the identified daylight, and for that, we need to use light bulbs that can be programmed to be dimmable under different settings. Finally, the AC thermostat also needs to be programmable because the microcontroller will send the signal to it when there is no person present in the room, so the AC temperature follows the pattern previously set.

5.2.1 Central Hub

After further research we were able to decide how we wanted to build the first subsystem of our project. Having in mind that this section will act like the “heart” of the system because it will have the main microcontroller that is going to be processing all the required data to be used in order to obtain an the wanted output, we picked components that have a low power consumption in order to follow our main requisite which is save energy, and also elements that were compatible with each other and those chosen to conformed the second subsystem.

5.2.1.1 Microcontroller

The microcontroller used in the central will be the “brain” of this subsystem and of the whole circuit. One of the function of this microcontroller is to gather information from the occupancy sensor in order to conclude if there is any person present in the room at the time and controls the lightning system by turning ON/OFF the lights and also controls the AC thermostat by setting it to the preferred temperature of the user if person is present or setting it to 78 degrees if no one is present. Another function of the microcontroller is to obtain the information from the ambient light sensor and send a signal to the dimmable light bulbs according to the daylight brightness detected in a specific room for the light bulb to bright at its specified setting according to the measured sunlight in the room. Moreover, the microcontroller will also obtain the data from the power monitoring nodes in order to calculate the power being consumed per appliance. It will also calculate from time to time the estimated power bill amount, and it will display both results: power consumed per appliance and estimated power bill, in the LCD. Having all of the previous factors in mind, we had to choose a microcontroller that could perform the previous functions, but also it needed to be a low power consumption device so it follows the purpose of our project.

There are literally several types of microcontrollers to choose from in the market today. They differ in CPU sizes, memory capabilities, type of architecture, power consumption, etc. Moreover, they can also be bought from many different vendors too, which makes it even harder to decide on which microcontroller to obtain. Some of the most popular microcontrollers are: ARM, Atmel, Freescale (previously Motorola), Intel, Power PC, Silicon Laboratories, Texas Instruments, among others. Since there is such a wide variety of microcontrollers to choose from, some key aspects that need to be considered when deciding on the most appropriate one for any project are the following:

- Analog to Digital Conversion (i.e. Successive Approximation A/D Converters, Single Slope A/D Converter, Flash A/D)
- Digital to Analog Converters (i.e. Pulse Width Modulator technique)
- Idle/Halt/Wakeup mode
- Interrupts
- Mixed (Analog-Digital Signal)
- Number of available peripheral connections
- Power Consumption (i.e. low power consumption, high power consumption)
- Power Sources (i.e. Batteries, Wall Adapter, USB)
- Programming environment/ high level language compatibility
- Serial Port Adapters (i.e. UART, USART)
- Serial Communication Interface (i.e. SPI in Motorola, SCI, I2C Bus)
- Storage (i.e. Flash, EEPROM, SRAM)
- Vendors Characteristics (i.e. Availability of product, Delivery time estimated, Cost)

After carefully analyzing the required specifications of the microcontroller needed for our project, the desired capabilities are shown in Table 6:

Table 6: Desired Characteristics for the Microcontroller used in this Project

Characteristics	Desired Value
CPU size	16 bit
Maximum Speed	16 MHz
Power Consumption	Ultra-low to Low Power
Real Time Clock	Included
Serial Communication Interface	I2C, SPI
Serial Port Adapters	UART or USART
Storage	10 KB – RAM/ 128 KB-Flash
Watchdog Timer	Included

After researching and comparing the different options available to select the most suitable microcontroller, we carefully selected Texas Instruments as the desired manufacturer. The decision was made based on the wide variety of helpful resources provide by this manufacturer. Texas Instruments offers immediate availability of the product which is very important when we are building a project within two semesters of classes. Moreover, it also gives the option of ordering samples prior to make a decision of whether a component has to be bought. In addition, Texas Instruments also carries development tools to be used with the needed products, and they can be acquired for a low price or even for free. Since this manufacturer is widely recognized, finding productive information in the web will be manageable. Finally, all of the team members are familiar with the Texas Instruments products since the MSP-EXP430G2259 TI LaunchPad was used in our Embedded Systems class. Texas Instruments has an ample variety of microprocessor families; all of them aim a certain feature. The microcontroller family selected for the project is the MSP430 series. The products of this series surpass the specified requirements needed for the design. Moreover, they include some other features that will also supplement our project. The MSP430 family provides high performance at a low power expense which is the major objective of the S.H.A.P.E.R. The following Table 10 offers a comparison among the MSP430 family for

the 5, and 6 that provide ultra-low to low power consumption and are the series that best suit the requirements for the project.

Table 7: Comparison between MSP430 Family Series 5 and 6 Characteristics [7]

Series	5 Series	6 Series
Part Number Prefix	F5xx	F6xx
Max CPU Speed (MHz)	25	25
Max Flash (KB)	512	512
Max SRAM/RAM (KB)	66	66
GPIO	29-87	72-90
Comparator	Yes	Yes
Timer	Yes	Yes
ADC	Yes	Yes
UART	Yes	Yes
I2C	Yes	Yes
SPI	Yes	Yes
Multiplier	Yes	Yes
DMA	Yes	Yes
Op Amps	Yes	Yes
LCD	No	Yes
RTC	Yes	Yes
PMM	Yes	Yes
USB	Yes	Yes
Hardware Encryption (AES)	No	Yes
Voltage	1.8-3.6V	1.8-3.6V
Fast Wake-Up From Standby Mode	<5 us	<5 us

After carefully reviewing all the available products from the above mentioned MSP430 family series, and comparing prices and features, the microcontroller with the characteristics very similar to the ones required for the project is the 16 bit MSP430F6638. It can be acquired at an affordable price of \$10.58. It has low input voltage requirement (maximum of 3.6V) and a low active power of 330. And it also has a good amount of memory storage and a CPU speed of 20 MHz, we can conclude that the chosen microcontroller exceeds the expectations of the characteristics previously specified for our design. Shown below in Figure 12 is the Functional Block Diagram for the chosen microcontroller.

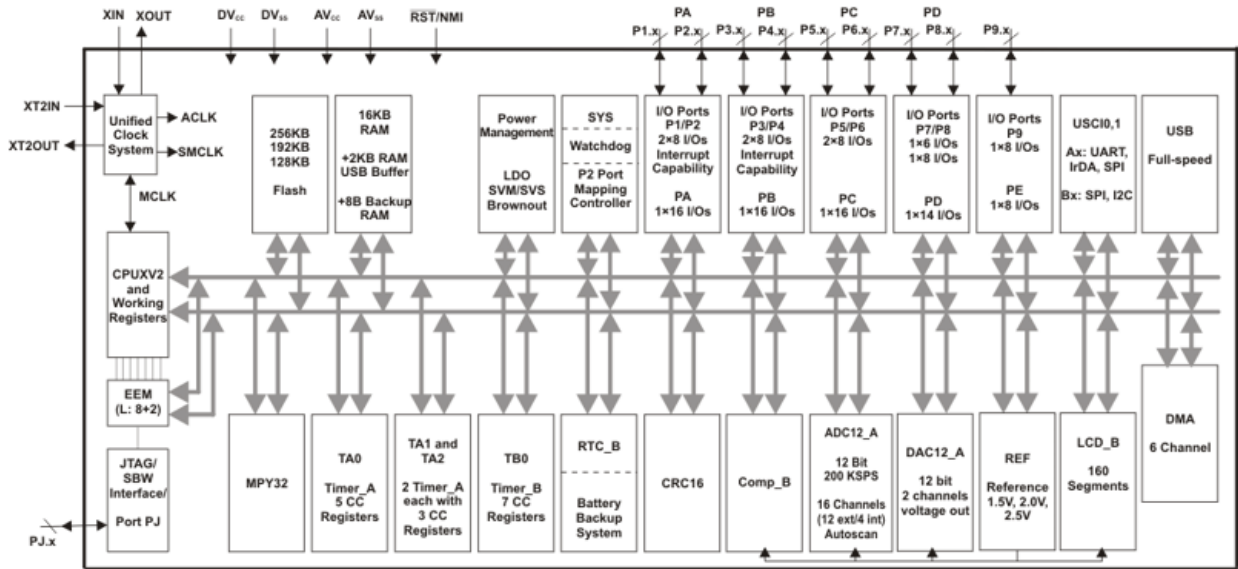

Note: Memory sizes and available peripherals and ports may vary, depending on the device.

Figure 12: Functional Block Diagram for Microcontroller MSP430F6638 [8]
(Image Courtesy of Texas Instrument)

Shown below in Figure 13 is the Pin Designation for the selected microcontroller:

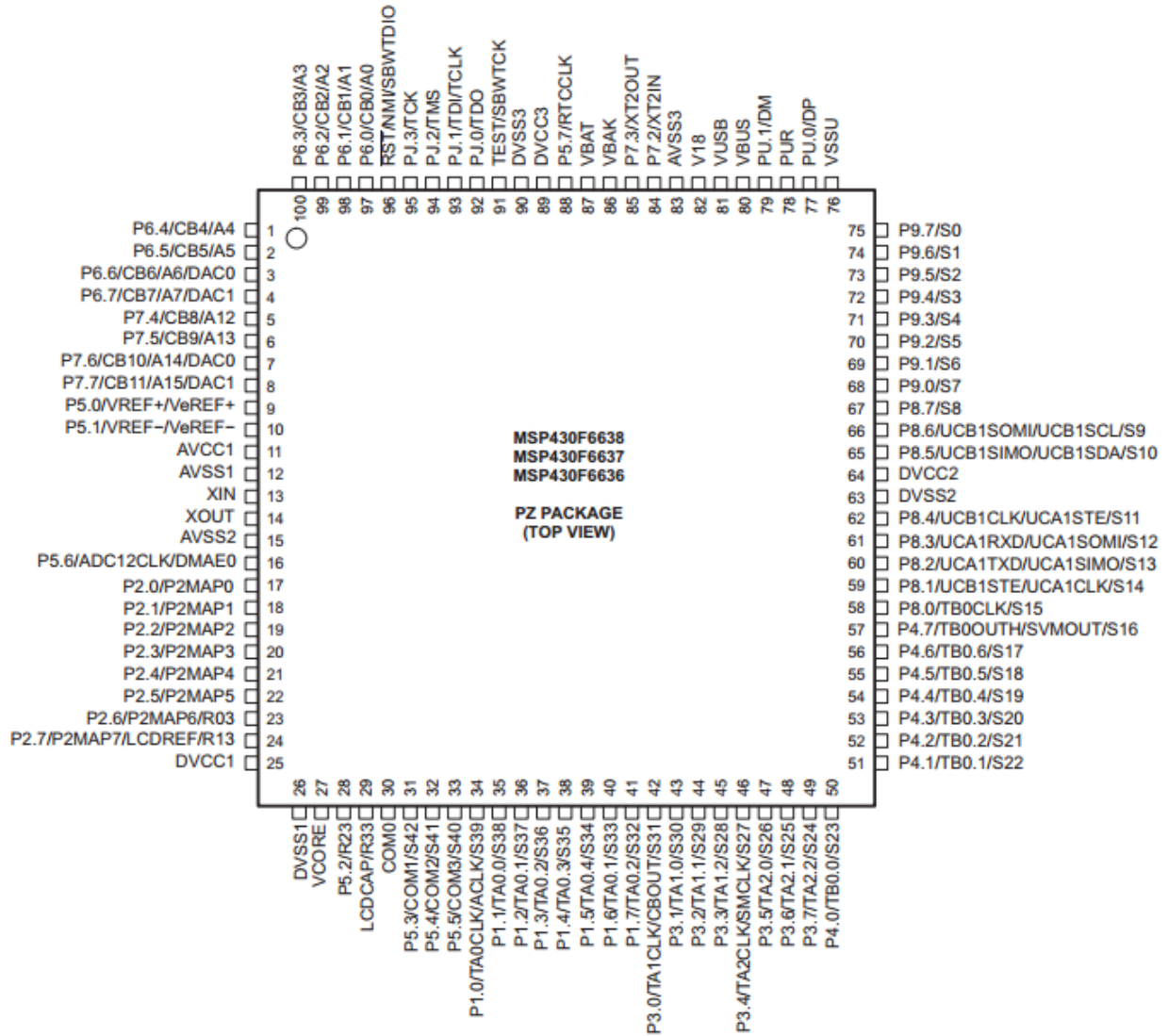

Figure 13: Pin Designation for Microcontroller MSP430F6638IPZR [8]
 (Image Courtesy of Texas Instruments)

A detailed description of the Pinout for the chosen microcontroller is shown in Table 8.1 through 8.5 obtained from the Texas Instruments MSP430F6638 Datasheet.

Table 8.1: Pinout Description of MSP430F6638 obtained from TI Datasheet [8]

Name	Pin Number	I/O	Description
P6.4/CB4/A4	1	I/O	General Purpose digital I/O Comparator_B input CB4 Analog input A4 – ADC
P6.5/CB5/A5	2	I/O	General Purpose digital I/O Comparator_B input CB5 Analog input A5 – ADC
P6.6/CB6/A6/DAC0	3	I/O	General Purpose digital I/O Comparator_B input CB6 Analog input A6 – ADC DAC12.0 output
P6.7/CB7/A7/DAC1	4	I/O	General Purpose digital I/O Comparator_B input CB7 Analog input A7 – ADC DAC12.1 output
P7.4/CB8/A12	5	I/O	General Purpose digital I/O Comparator_B input CB8 Analog input A12 – ADC
P7.5/CB9/A13	6	I/O	General Purpose digital I/O Comparator_B input CB9 Analog input A13 – ADC
P7.6/CB10/A14/DAC0	7	I/O	General Purpose digital I/O Comparator_B input CB10 Analog input A14 – ADC DAC12.0 output
P7.7/CB11/A15/DAC1	8	I/O	General Purpose digital I/O Comparator_B input CB11 Analog input A15 – ADC DAC12.1 output
P5.0/VREF+/VeREF+	9	I/O	General-Purpose digital I/O Output of Reference voltage to the AC Input for an external reference voltage to the ADC
P5.1/VREF-/VeREF-	10	I/O	General-Purpose digital I/O Negative terminal for the ADC's reference voltage for both sources, the internal reference voltage, or an external applied reference voltage
AVCC1	11		Analog power supply
AVSS1	12		Analog ground supply

Table 8.2: Pinout Description (Cont.) of MSP430F6638 obtained from TI Datasheet [8]

Name	Pin Number	I/O	Description
XIN	13	I	Input terminal, crystal oscillator XT1
XOUT	14	O	Output terminal, crystal oscillator XT1
AVSS2	15		Analog ground supply
P5.6/ADC12CLK/DMAE0	16	I/O	General Purpose digital I/O Conversion clock output ADC DMA external trigger input
P2.0/P2MAP0	17	I/O	
P2.1/P2MAP1	18	I/O	
P2.2/P2MAP2	19	I/O	
P2.3/P2MAP3	20	I/O	
P2.4/P2MAP4	21	I/O	
P2.5/P2MAP5	22	I/O	
P2.6/P2MAP6/R03	23	I/O	
P2.7/P2MAP7/LCDREF/R13	24	I/O	
DVCC1	25		Digital power supply
DVSS1	26		Digital ground supply
VCORE(2)	27		Regulated core power supply (internal use only, no external current loading)
P5.2/R23	28	I/O	
LCDCAP/R33	29	I/O	LCD capacitor connection Input/output port of most positive analog LCD voltage (V1) CAUTION: LCDCAP/R33 must be connected to DVSS if not used.
COM0	30	O	LCD common output COM0 for LCD backplane
P5.3/COM1/S42	31	I/O	General-purpose digital I/O LCD common output COM1 for LCD backplane LCD segment output S42
P5.4/COM2/S41	32	I/O	General-purpose digital I/O LCD common output COM2 for LCD backplane LCD segment output S41
P5.5/COM3/S40	33	I/O	General-purpose digital I/O LCD common output COM3 for LCD backplane LCD segment output S40
P1.0/TA0CLK/ACLK/S39	34	I/O	
P1.1/TA0.0/S38	35	I/O	
P1.2/TA0.1/S37	36	I/O	

Table 8.3: Pinout Description (Cont.) of MSP430F6638 obtained from TI Datasheet [8]

Name	Pin Number	I/O	Description
P1.3/TA0.2/S36	37	I/O	
P1.4/TA0.3/S35	38	I/O	
P1.5/TA0.4/S34	39	I/O	
P1.6/TA0.1/S33	40	I/O	
P1.7/TA0.2/S32	41	I/O	
P3.0/TA1CLK/CBOUT/S31	42	I/O	
P3.1/TA1.0/S30	43	I/O	
P3.2/TA1.1/S29	44	I/O	
P3.3/TA1.2/S28	45	I/O	
P3.4/TA2CLK/SMCLK/S27	46	I/O	
P3.5/TA2.0/S26	47	I/O	
P3.6/TA2.1/S25	48	I/O	
P3.7/TA2.2/S24	49	I/O	
P4.0/TB0.0/S23	50	I/O	
P4.1/TB0.1/S22	51	I/O	
P4.2/TB0.2/S21	52	I/O	
P4.3/TB0.3/S20	53	I/O	
P4.4/TB0.4/S19	54	I/O	
P4.5/TB0.5/S18	55	I/O	
P4.6/TB0.6/S17	56	I/O	
P4.7/TB0OUTH/SVMOUT/S16	57	I/O	
P8.0/TB0CLK/S15	58	I/O	
P8.1/UCB1STE/UCA1CLK/S14	59	I/O	
P8.2/UCA1TXD/UCA1SIMO/S13	60	I/O	
P8.3/UCA1RXD/UCA1SOMI/S12	61	I/O	
P8.4/UCB1CLK/UCA1STE/S11	62	I/O	
DVSS2	63		Digital ground supply
DVCC2	64		Digital power supply
P8.5/UCB1SIMO/UCB1SDA/S10	65	I/O	
P8.6/UCB1SOMI/UCB1SCL/S9	66	I/O	
P8.7/S8	67	I/O	
P9.0/S7	68	I/O	
P9.1/S6	69	I/O	
P9.2/S5	70	I/O	
P9.3/S4	71	I/O	
P9.4/S3	72	I/O	
P9.5/S2	73	I/O	
P9.6/S1	74	I/O	
P9.7/S0	75	I/O	
VSSU	76		USB PHY ground supply
PU.0/DP	77	I/O	
PUR	78	I/O	
PU.1/DM	79	I/O	

Table 8.4: Pinout Description (Cont.) of MSP430F6638 obtained from TI Datasheet [8]

Name	Pin Number	I/O	Description
VBUS	80		USB LDO input (connect to USB power source)
VUSB	81		USB LDO output
V18	82		USB regulated power (internal use only, no external current loading)
AVSS3	83		Analog ground supply
P7.2/XT2IN	84	I/O	
P7.3/XT2OUT	85	I/O	
VBAK	86		Capacitor for backup subsystem. Do not load this pin externally For capacitor VBAK 86 A7 values, see CBAK
VBAT	87		Backup or secondary supply voltage. If backup voltage is not supplied, connect to DVCC externally.
P5.7/RTCCLK	88	I/O	
DVCC3	89		Digital power supply
DVSS3	90		Digital ground supply
TEST/SBWTK	91	I	
PJ.0/TDO	92	I/O	
PJ.1/TDI/TCLK	93	I/O	
PJ.2/TMS	94	I/O	
PJ.3/TCK	95	I/O	
RST(NOT)/NMI/SBWTDIO	96	I/O	Reset input (active low) Non-maskable interrupt input Spy-bi-wire data input/output
P6.0/CB0/A0	97	I/O	
P6.1/CB1/A1	98	I/O	
P6.2/CB2/A2	99	I/O	
P6.3/CB3/A3	100	I/O	

As seen above, this microcontroller has a good amount of pins, which is beneficial for the design because the controller will be able to provide the desired commands to all the required peripherals.

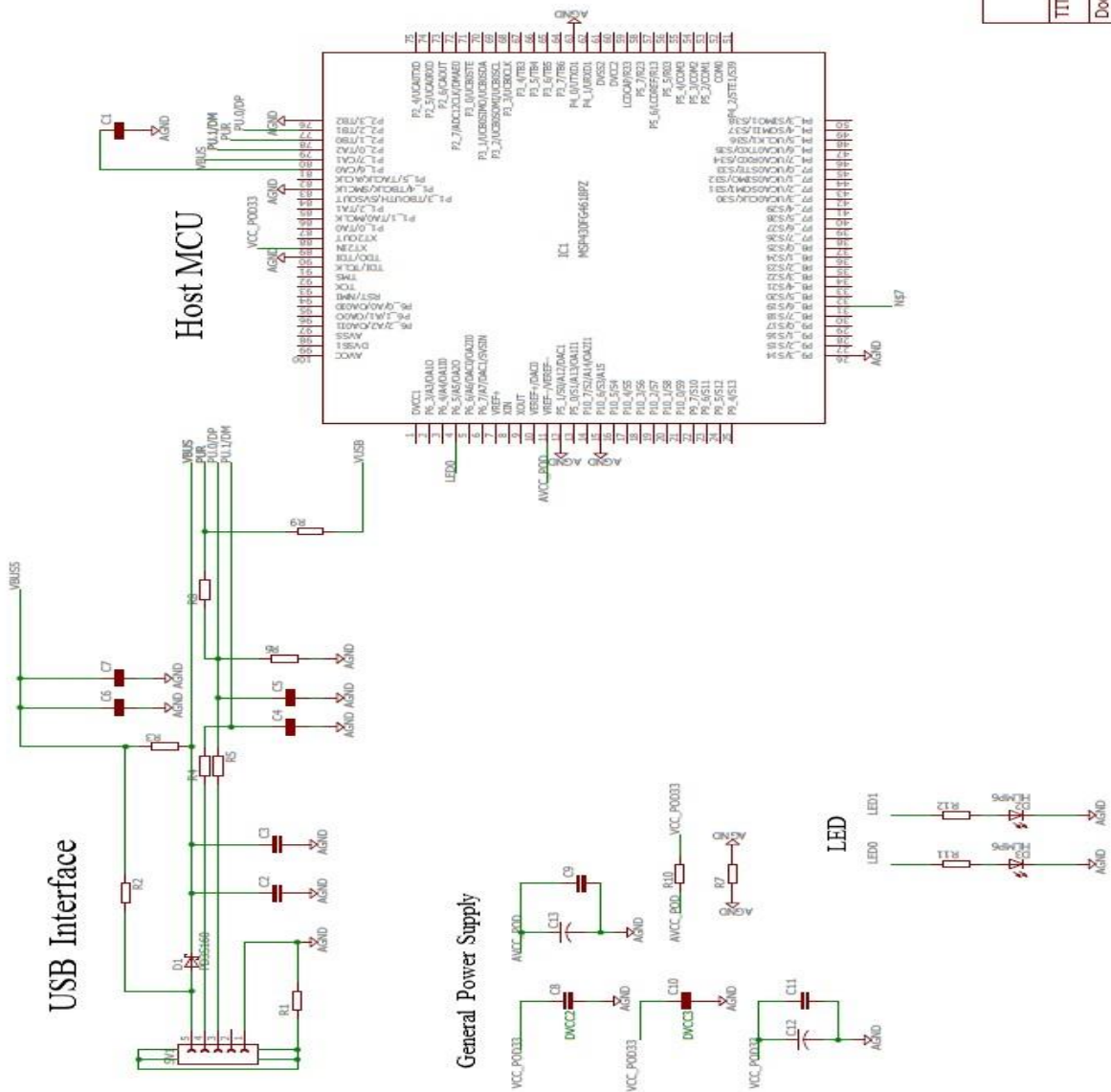

Figure 14: Microcontroller designed to be used for S.H.A.P.E.R.

Group 18

TITLE: MSP430FG6182Z

Document Number: REV:

(Different Design was used because original MCU was not found on EagleCad, refer to pin numbers for real configuration)

5.2.1.2 PIR Motion Sensor with Embedded Microcontroller

Sensors act like the “eyes” of the home automation system because they acquire the needed information from the surrounding environment and convert it into the electrical data that will be used by the microcontroller in order to be processed and have the system perform the desired functions. The occupancy sensors, as its name states, are the ones that will give us information about the presence of people in a certain room of the house. As previously noted, there are many types of light sensors that help in the regulation of lighting, external light source detection and lighting is regulation by occupation of an area. This dimmable lighting system will be implemented into areas of the home that is mostly used by a user such as bedroom, kitchen, bathroom, etc. The basic implementation of this device is to detect motion and if motion is detected, the light will turn ON. At this point, this is related to an occupancy sensor that contains a beam, such as infrared for example which can record and measure differences in temperature. If the light detects an increase in temperature, as per the human body internal body temperature is usually higher than room temperature. Right now, the light system turns on when a significant amount of temperature is measured so as to ensure it doesn't turn on if a fly or small animal moves in the room because that would be inefficient. Moreover, if there was someone present in the room, but leaves it, the occupancy sensor will also record that difference in temperature of the room, so it will detect that no one is in the room at the moment, and the lightning system will automatically turn OFF. In addition to this feature, the information obtained from the motion sensors will also trigger the signal for the AC thermostat for the temperature of the same will be preset to a value in the case a person is present in the room, and it will be preset to 78 Fahrenheit degrees or higher if a person leaves the room or no one is in the room. After doing further research, we decided to use a PIR board. Shown in Table 9 are the desired characteristics for this project:

Table 9: Desired Characteristics for the PIR Motion Sensor Board used in this Project

Desired Characteristics	Desired Value
Voltage Supply	3V-5V
Microcontroller Included	Yes
Communication Interface Included	Yes
Type of Output	Digital

After considering the above characteristics, we decided to research further on components that present similar features in order to select the one that best suits our requirements. A comparison of some of the boards considered are displayed in the Table 10:

Table 10: Comparison of PIR Motion Sensor Boards Considered for this Project

Series/Manufacturer	/Olimex LTD[9]	/SparkFun Electronics[10]	ZMOTION/Zilog[11]
Voltage Supply	3V-6V	5V-12V	5V
Embedded	Yes/ MCU, 16-Bit	No	Yes, MCU, 8-Bit
Utilized IC/Part	MSP430F2013	SE-10	RE200B, Z8FS040
Communication Interface Included	Yes, Supports SPI and I2C		Yes
Manufacturer Part Number	MSP430-PIR	SEN-13285	ZEPIR000103ZR DG
Price gotten from DigiKey	\$18.32	\$9.95	\$265.00

After carefully reviewing the features present in these three boards and doing some more research on them, we decided to use the MSP430-PIR. This part is the one that best suits our project because includes a MCU which makes the recompilation of information easier and more accurate. We could find less expensive PIR motion sensors if no processor was embedded in the part, but we want the measurements to be as accurate as possible in order to deliver a good product. Moreover, the board offers ultralow-power consumption, five power-savings modes, and a low power PIR motion that also contribute to our goal of saving power. In addition, some other features of the board that are also very attractive for the project are: the low supply voltage range of 1.8V to 3.6V (as mentioned above same voltage range as our main microcontroller, which makes it very compatible); JTAG connector; CR2032 battery holder; supports both Olimex and TI SBW layout; status LEDs; and dimensions of 42.27x25.89mm (making it small enough to fit our needs). [12]

Using the integrated 16-bit Sigma-Delta analog-to-digital converter (ADC) and built-in front-end PGA (SD16_A), the MSP430F2013 provides all the required elements for interfacing to the PIR sensor in a small footprint. With integrated analog and a 16-MHZ 16-bit RISC CPU, the MSP430F2013 offers a great deal of processing performance in a small package at a low cost. [12]

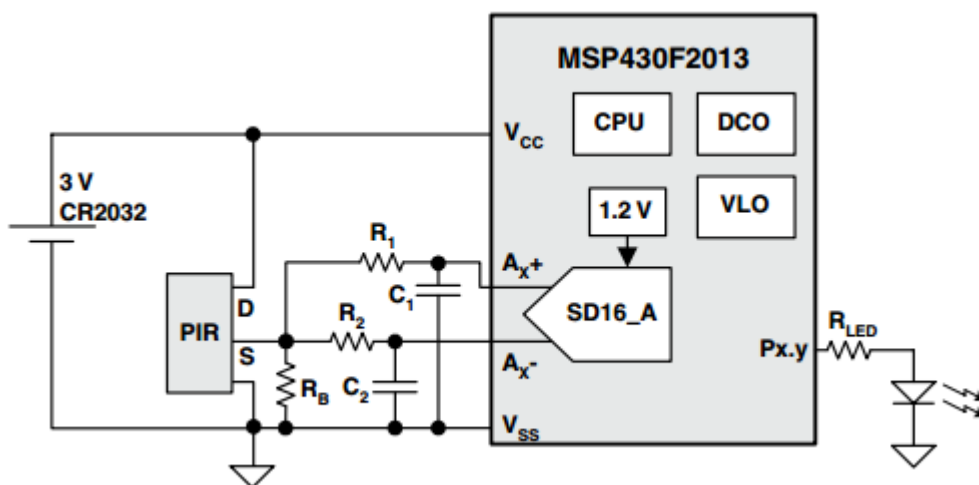

Figure 15: MSP430F2013 Motion Detection System [12]

(Image Courtesy of Texas Instruments)

The output information obtained from this circuit will be directed to the microcontroller in the main hub, so it processes the up to date information obtained and proceed to send the required signals to the systems that depend on the occupancy sensor.

According to Olimex, Figure 15 shows a simplified circuit that is used to process the PIR sensor output signal. The external components consist of the bias resistor, R_B , required for the sensor and two RC filters formed by R_1/C_1 and R_2/C_2 . The two filters serve two different purposes. Because the input to the SD16_A is differential, both a positive and negative input must be provided. R_1/C_1 serves as an antialiasing filter on the $AX+$ input. The second RC filter made up of R_2/C_2 serves to create a DC bias for the $AX-$ input of the SD16_A. This is required due to the large offset of the PIR source output with respect to VSS with relation to the input range specification for the SD16_A. In addition to the PIR sensor and the analog signal conditioning, a port pin is used to drive an LED. The LED is illuminated to indicate to the user that motion has been detected. This signal could also be used to drive an analog switch or relay to turn on a lamp or otherwise indicate motion in a real-world system. As a final aspect of the hardware design, use of a Fresnel lens is critical to establishing good directionality of the sensor detection field. The internal architecture of the dual element sensor provides good noise immunity and false trigger rejection but also creates a limited directionality of the sensor's sensitivity. Use of the lens widens this field, making the final solution more robust. [4]

Shown in Figure 16 is the block diagram of the MSP430PIR development board and Figure shows the MSP430 PIR Sensor Schematic:

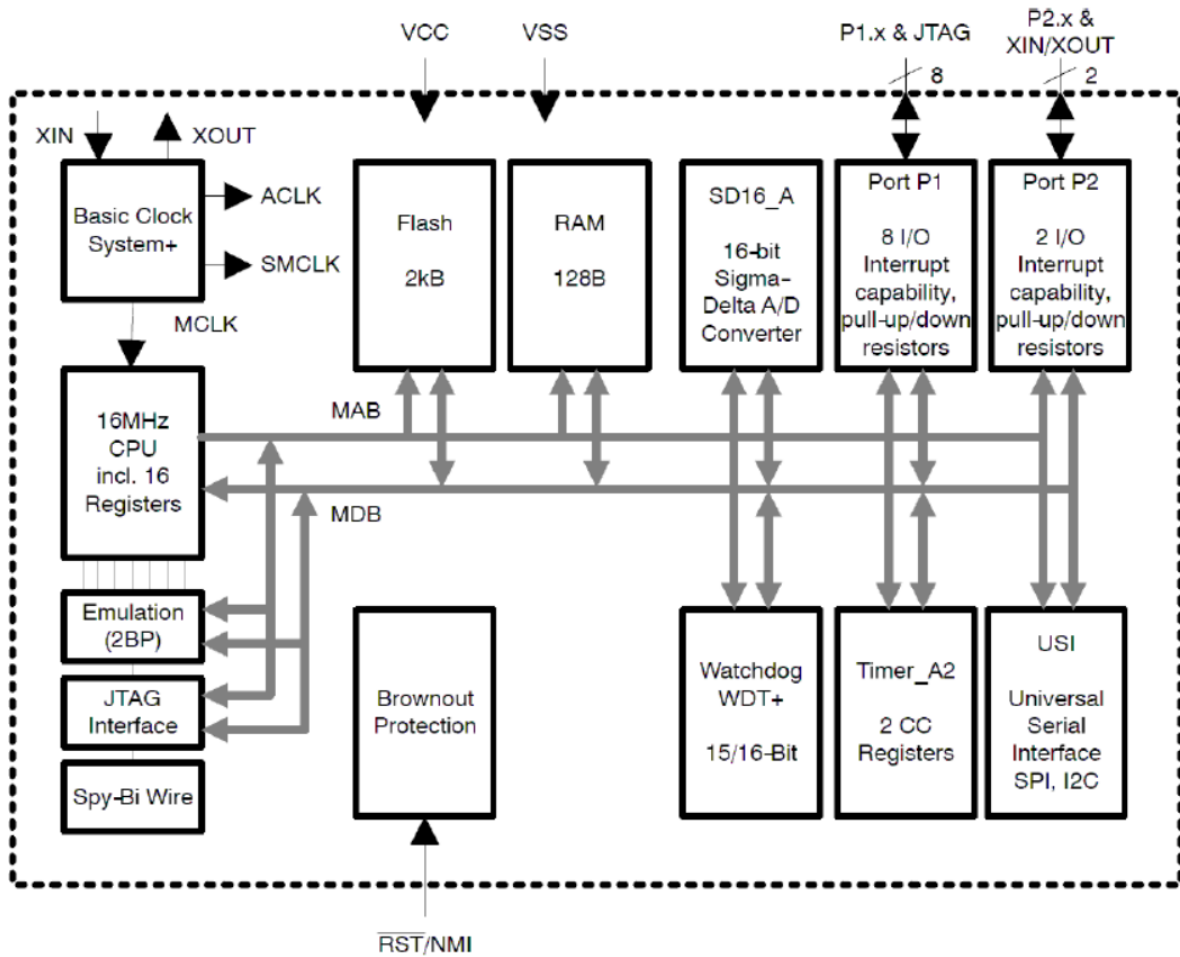

Figure 16: MSP430-PIR Sensor Block Diagram [4]
 (Image Courtesy of Texas Instruments)

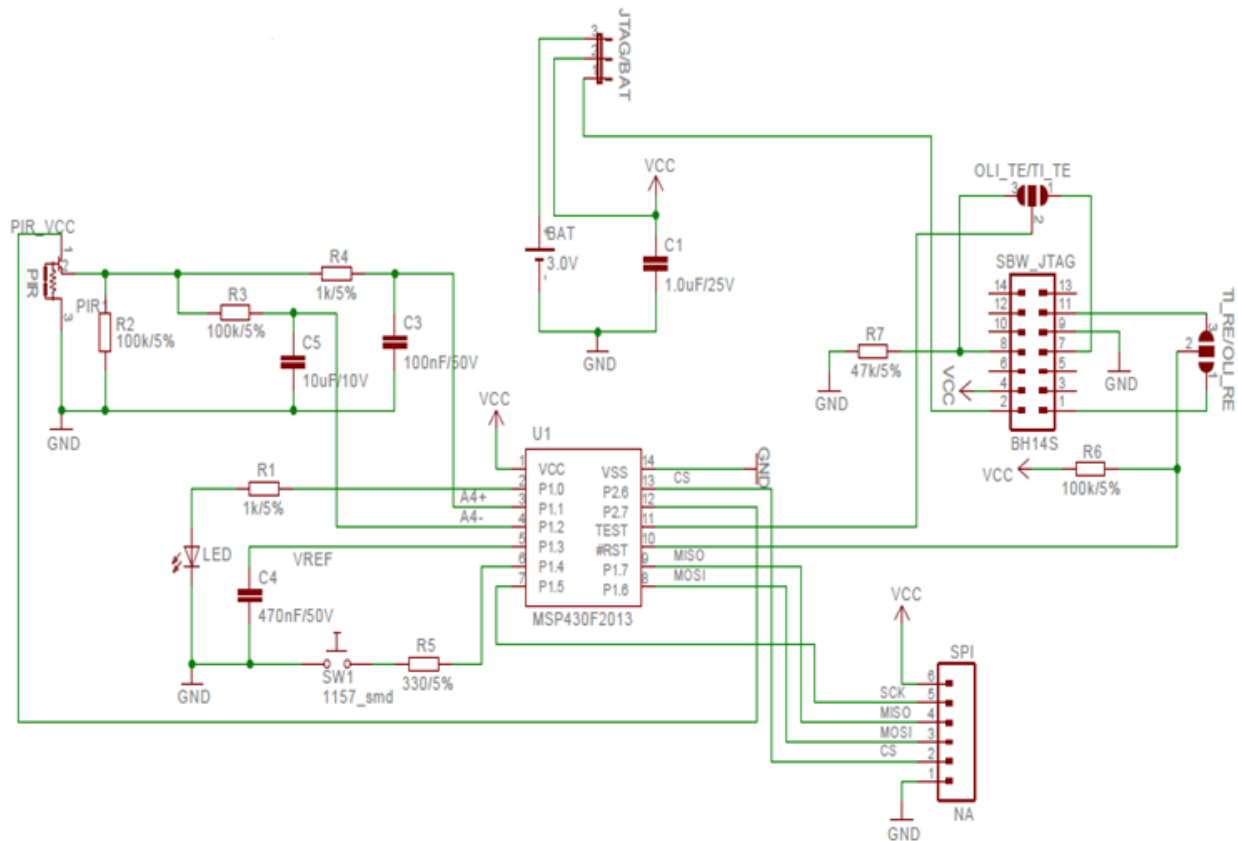

Figure 17: MSP430-PIR Sensor Schematic [4]
 (Image Courtesy of Texas Instruments)

Another important hardware characteristics offered by this component is the fact that the microcontroller embedded in the board, the MSP430F2013 has an Ultrafast Wake-Up from low-power modes; it does it in less than $1\mu\text{s}$, which means that once the sensor detects a change in temperature in the room, when a person enters, it will send a signal in order for the system to get activated again. This will take less than $1\mu\text{s}$. Also, in Active Mode will operate from $220\mu\text{A}$ at 1MHz , 2.2V ; in StandBy Mode at $0.5\mu\text{A}$; and in Off Mode at $0.1\mu\text{A}$. Add to that, that the basic clock module configuration includes internal very low power LF oscillator and a 32KHz crystal which also contributes to the component's achievement of low power consumption. Once again, the processor consumes minimum amount of current when not in active mode which helps to achieve our project goal of saving energy by monitoring power consumption. Moreover, it has most of the capabilities of a standard MSP430 microcontroller which include, but are not limited to: Universal Serial Interface (USI) supporting SPI and I2C; 16-bit Timer_A with two capture, compare registers; 16-bit Sigma-Delta A/D converter with differential PGA inputs and internal reference; 16 bit RISC architecture, 62.5 ns instruction cycle time; brownout detector; 2KB plus 256KB of flash memory, and 128B of RAM. This makes the PIR sensor board extremely helpful and easy to implement in our project. It also includes a serial onboard programming and an on-chip emulation logic with spy-bi-wire (SBW) interface which help in the process of debugging and program development. Typical applications include sensor systems that capture analog signals, convert them to digital values, and then process the data for display or for transmission to a host system. Stand Alone RF sensor front end is another area of application. []

Figure 18 shows the functional diagram of the microcontroller embedded in the MSP-PIR board, the MSP430F2013:

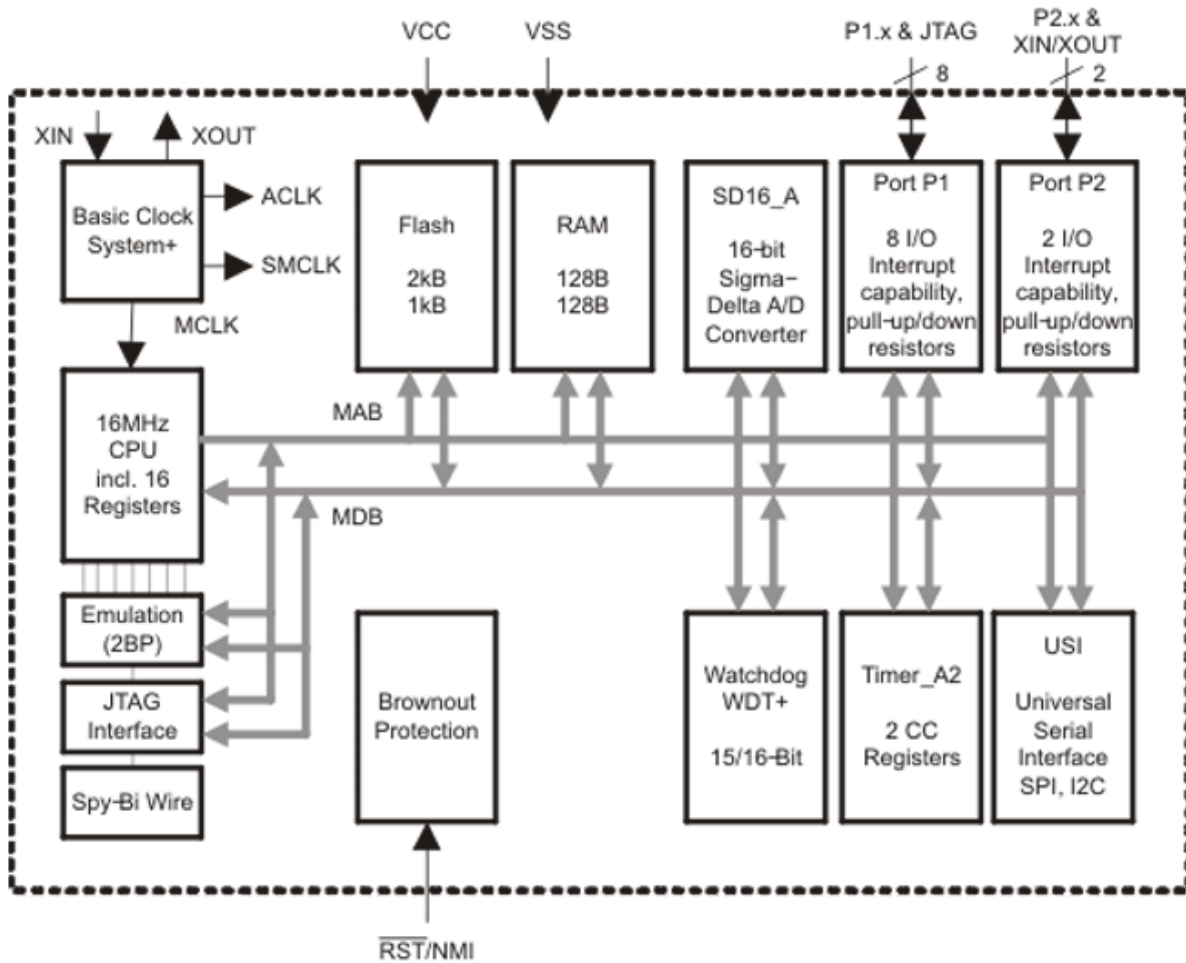

Figure 18: Functional Block Diagram for Microcontroller used in MSP430-PIR board, the MSP430F2013 [12]
 (Image Courtesy of Texas Instrument)

5.2.1.3 Bluetooth Component

In order for the microcontroller to obtain information from the power monitoring nodes, it will need to establish wireless communication with the same because the power monitoring stations will be spread out over different rooms in the house. Therefore, a type of wireless component needs to be integrated in the main hub. In our case, we are choosing to use Bluetooth protocol to communicate wirelessly; thus, a component that supports Bluetooth needs to be added to the principal circuit. After doing some research, a particular device used in one of the previous design project, Smart Home Energy Monitoring System (S.H.E.M), was preferred by the team members to be used. The Dual-Mode Bluetooth CC2564 from Texas Instruments. The CC2564BRVMT; a Dual-Mode Bluetooth CC2564 Controller that when coupled with a microcontroller unit (MCU), the HCI device provides be in class RF performance.[13]

The given component has Low Energy (LE) featured fully compliant with the Bluetooth 4.0 specifications. This is the same version featured by both Bluetooth modules: the one incorporated in the monitoring stations, and the one integrated with the PIR Motion Sensor; this will ease the communication among all the components of the system. It also features flexibility for easy stack integration and validation into various microcontrollers, such as MSP430 and ARM Cortex-M3 and Cortex M4 MCUs. [13] This is very convenient for our main microcontroller is an MSP430, and compatibility between the parts is of main importance. Finally, the device presents low power consumption for active mode, standby and scan Bluetooth modes. Moreover, it also has shutdown and sleep modes to minimize power consumption. [13] This characteristic was the main reason why we were so attracted to this device because we are really concerned about saving energy. Figure 19 shows a functional block diagram of the CC2564BRVMT component.

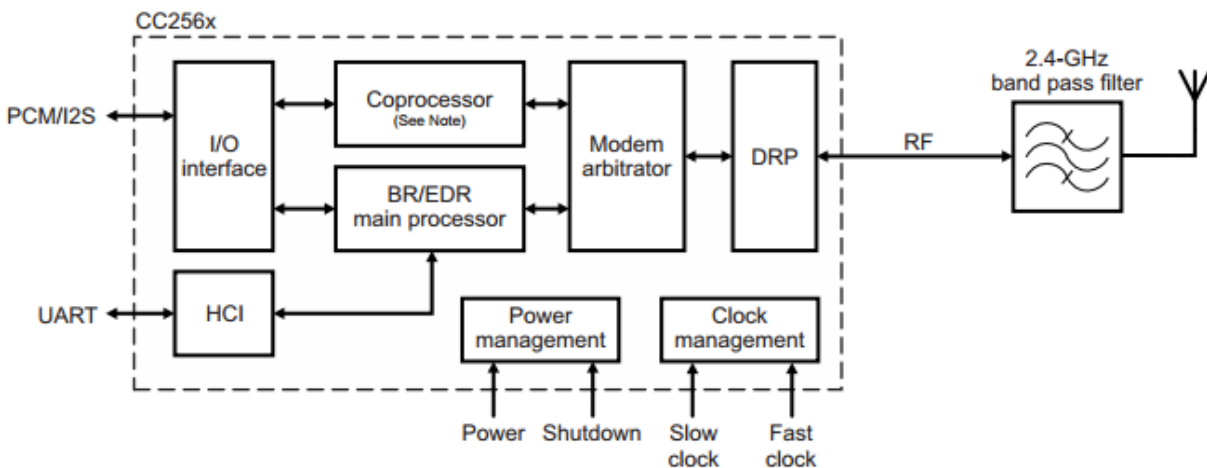

Figure 19: Functional Block Diagram of the Dual-Mode Bluetooth CC2564BRVMT [13] (Image Courtesy of Texas Instruments)

5.2.1.4 Light Dimmer Circuit

Most lighting systems today include a dimming feature that allows for low power consumption proper light adjustment for lighting systems. The dimming concept was revolutionized by Joel Spira, a physicist who was fascinated in the invention of the light bulb and its physical properties. His work involved using a device called a rheostat which absorbs electrical energy and converts to heat rather to light according to National Geographic [14]. By utilizing a thyristor, which interrupts electricity instead of absorbing it causes it to pulse instead of flow freely according to National Geographic [14]. The invention sprung and was realized. The new switch produced a lot less heat and also did not use up a lot of electricity. Its size was a lot smaller so that the ordinary person could utilize in their home. With this new implementation came the rise of many products of the light dimmer such as the Nova, the first linear slide dimmer, GRAFIK Eye system and many others according to Lutron.com [15]. This revolutionary and yet simple change in the lighting will help the S.H.A.P.E.R. realize its design implementation for the dimming system. Dimming circuits are very useful and abundant in variations which will give more flexibility to choosing one. Before dimmers, lighting systems used variable resistors that did not do well in conducting electrical current. The voltage levels would come out very weak and efficiency was very bad as well. Since the old circuit's design was made that the resistors were put into series, voltage drop would result

in the lighting system and uses up power. Thus, not providing enough light output and can be inconvenient for a user. The main concern for this design was that it also used up a lot of heat in the lighting process. So the dimmer as discussed before was able to alleviate that problem since heat can ruin a circuit's internal structure and burn out critical components of the light system.

Since this project will be working with LEDs, there may be some compatibility issues since "traditional line-voltage dimming controls was designed for incandescent bulbs" according to ecmweb.com. So since this is an issue, it would be better to either design the circuit ourselves which have been done and there are a few resources available or purchase a programmable LED to shorten the time frame of designing the system. One example is the TRIAC Texas Instruments. To get familiar with how the dimming system will work. The LM3445 Triac Dimmable Offline LED Driver board will serve as an example [16]. In the following figure below so the dimming circuit at the basic level.

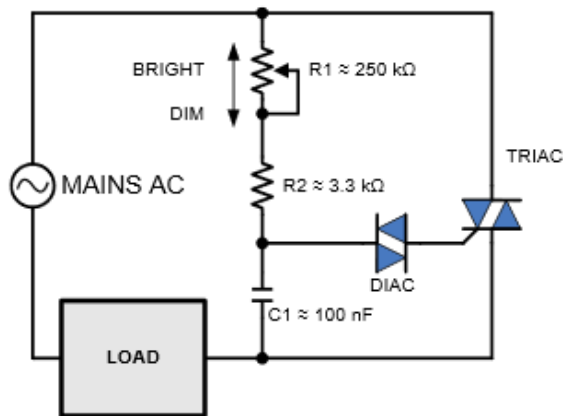

Figure 20: Simple Light Dimmer Circuit [16]
(Image Courtesy of Texas Instruments)

The circuit has an alternating current source in order to regulate voltage levels and provide enough power to the light system. The specifications involve a voltage of 90 V AC which is more than enough to provide power to the LEDs. According to Texas Instrument datasheet, this circuit can support up to 7 LEDs if needed. Since small LEDs will be more economically for the group's purpose, more than LED will have to be purchased.

The following circuit provided by Texas Instruments shows the circuitry at the circuit level. The benefit of this design is that it already has its own AC-DC current controller to be compatible with TRIAC dimmers. With this design or something similar will help in simplifying the process for designing a dimmer system to work with the MSP430 microcontroller.

Table 11: Desired Characteristics for the Bluetooth Component used in this Project

Characteristics	Desired Value
Bluetooth Version	4.0
Tx and Rx	Yes
Memory Size	128 kB Flash, 8kB RAM
Serial Interfaces	SPI
Low Energy Consumption	Yes
Data Rate (Max)	≥1Mbps

After analyzing the desired characteristics of the Bluetooth component, we decided that we were going to acquire a Bluetooth module that includes a microcontroller in order to better process the information. The information will be sent from this microcontroller to the one in the main hub. A comparison of some of the characteristics considered are displayed in the Table 12:

Table 12: Comparison of Microcontroller with Integrated Bluetooth Component Considered for this Project [17]

Manufacturer	Texas Instrument	Texas Instrument	STMicroelectronics
Manufacturer Part Number	CC2540F256RHAT	CC2541F256RHAR	BLUENRGQTR
Bluetooth Version	4.0	4.0	4.0
Voltage Supply	2V-3.6V	2V-3.6V	2V-3.6V
Operating Temperature	-40°C to 85°C	-40°C to 85°C	-40°C to 85°C
Current Receiving	22.1mA	17.9mA	7.7mA
Current Transmitting	31.6mA	18.2mA	8.2mA
Serial Interfaces	SPI, UART	I2C, SPI, UART	SPI
Data Rate (Max)	1Mbps	2Mbps	1Mbps
Tx+Rx	Yes	Yes	Yes
Memory Size	256kB Flash, 8kB RAM	256kB Flash, 8kB RAM	64kB Flash/12kB RAM
Low Energy	Yes	Yes	Yes
Price at DigyKey	\$7.05 per Unit	\$5.67 per Unit	\$1.36 per Unit

As seen in the previous table, both of the Texas Instruments microcontrollers are suitable for the project because they have similar characteristics. However, after further research we decided to select the CC2541F256RHAR part because its features give us more flexibility at the time of using interfacing the power monitoring nodes with the main hub. Moreover, after further research on both SoCs, we discover that: The CC2541 is pin-compatible with the CC2540 in the 6-mm × 6-mm QFN40 package, if the USB is not used on the CC2540 and the I2C/extra I/O is not used on the CC2541. Compared to the CC2540, the CC2541 provides lower RF current consumption. The CC2541 does not have the USB interface of the CC2540, and provides lower maximum output power in TX mode. The CC2541 also adds a HW I2C interface. [18]

Other characteristics that are also important for the hardware design of this component include, but are not limited to: supports 250kbps, 500 kbps, 1Mbps and 2Mbps data rates which is of great benefit for the wireless communication between both subsystems; it has a programmable output power up to 0dBm, which is also beneficial because the system will save power; it has excellent receiver sensitivity, and blocking performance.

According to Texas Instruments, low power features include: active node Rx node down to: 17.9 mA; active Mode Tx (0 dBm): 18.2 mA; Power Mode 1 (4 μ s Wake-Up): 270 μ A; Power Mode 2 (Sleep Timer On): 1 μ A; Power Mode 3 (External Interrupts): 0.5 μ A; Wide Supply Voltage Range (2V-3.6V).[] Moreover, Peripherals include: Powerful Five-Channel DMA; General-Purpose Timers (One 16-Bit, Two 8-Bit); IR Generation Circuitry; 32-kHz Sleep Timer With Capture; Accurate Digital RSSI Support; Battery Monitor and Temperature Sensor; AES Security Coprocessor; Two Powerful USARTs With Support for Several Serial Protocols; 23 General-Purpose I/O Pins (21 \times 4 mA, 2 \times 20 mA); I2C interface; 2 I/O Pins Have LED Driving Capabilities; Watchdog Timer; Integrated High-Performance Comparator. [18]

All of the previous characteristics will help improve our design and the communication between the central hub and the power monitoring stations. In addition, since the microcontroller and the Bluetooth are integrated in one chip, the monitoring station capsule will be smaller than if we would have used the two components separately. Moreover, having a chip with all the previous microcontroller capabilities, will reduce the amount of wires and hardware components in the nodes PCBs.

Displayed in Figure 22 is a block diagram of the System-on-Chip (SoC) selected for our design:

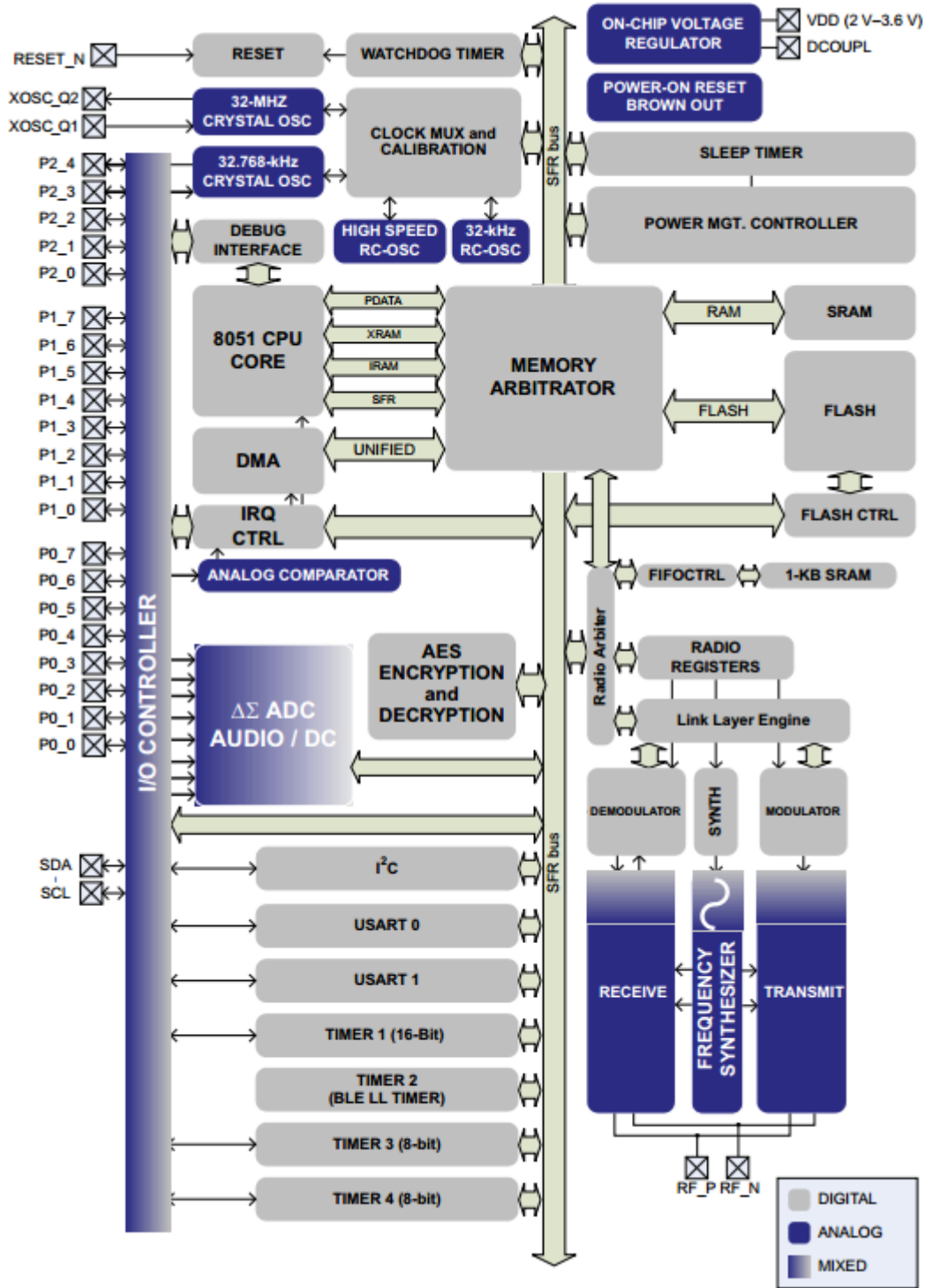

Figure 22: Block Diagram of the 2.4-GHz Bluetooth Low Energy and Proprietary SoC CC2541F256RHAR [18]
 (Image Courtesy of Texas Instruments)

A detailed description of the components in the block diagram is as follows can be found in the datasheet of the Texas Instruments' correspondent component. However, here is the description of

the most important sections that have direct impact in our design. Information was extracted from Texas Instruments Datasheet.

CPU and Memory:

The 8051 CPU core is a single-cycle 8051-compatible core. It has three different memory access busses (SFR, DATA, and CODE/XDATA), a debug interface, and an 18-input extended interrupt unit. The memory arbiter is at the heart of the system, as it connects the CPU and DMA controller with the physical memories and all peripherals through the SFR bus. The memory arbiter has four memory-access points, access of which can map to one of three physical memories: an SRAM, flash memory, and XREG/SFR registers. It is responsible for performing arbitration and sequencing between simultaneous memory accesses to the same physical memory. The SFR bus is drawn conceptually in Figure 22 as a common bus that connects all hardware peripherals to the memory arbiter. The SFR bus in the block diagram also provides access to the radio registers in the radio register bank, even though these are indeed mapped into XDATA memory space. The 8-KB SRAM maps to the DATA memory space and to parts of the XDATA memory spaces. The SRAM is an ultralow-power SRAM that retains its contents even when the digital part is powered off (power mode 2 and mode 3). The 128/256 KB flash block provides in-circuit programmable non-volatile program memory for the device, and maps into the CODE and XDATA memory spaces.[18]

Peripherals:

A versatile five-channel DMA controller is available in the system, accesses memory using the XDATA memory space, and thus has access to all physical memories. Each CC2541 contains a unique 48-bit IEEE address that can be used as the public device address for a Bluetooth device. Designers are free to use this address, or provide their own, as described in the Bluetooth specification. The I/O controller is responsible for all general-purpose I/O pins. The CPU can configure whether peripheral modules control certain pins or whether they are under software control, and if so, whether each pin is configured as an input or output and if a pullup or pulldown resistor in the pad is connected. Each peripheral that connects to the I/O pins can choose between two different I/O pin locations to ensure flexibility in various applications. USART 0 and USART 1 are each configurable as either an SPI master/slave or a UART. They provide double buffering on both RX and TX and hardware flow control and are thus well suited to high-throughput full-duplex applications. Each USART has its own high-precision baud-rate generator, thus leaving the ordinary timers free for other uses. When configured as SPI slaves, the USARTs sample the input signal using SCK directly instead of using some oversampling scheme, and are thus well-suited for high data rates. The I2C module provides a digital peripheral connection with two pins and supports both master and slave operation. I2C support is compliant with the NXP I2C specification version 2.1 and supports standard mode (up to 100 kbps) and fast mode (up to 400 kbps). In addition, 7-bit device addressing modes are supported, as well as master and slave modes. [18]

5.2.2.2 Power Monitoring IC

After further research on how to set up a system that is able to measure current and voltage in order to obtain the power consume by a determined appliance, the idea that we came with is to use a current shunt/power monitor IC. In this case we will have to measure the DC component of the current flowing through the appliance; therefore, an AC/DC converter will be needed in order to

measure the desired current and voltage values. To start obtaining the current measurements, the shunt resistor and sensing circuitry need to be connected directly to the monitored appliance. There are two ways to measure current using a current shunt: low-side sensing and high-side sensing. The first one describes when the sense resistor is placed between the load and the ground. On the other hand, the high-side sensing describes when the current is measured between the supply voltage and the load. In our case, we want to measure the power being used by a certain appliance; thus, the circuit will be positioned between the power supply and the desired element. Moreover, to calculate wanted power, an integrated circuit with such capabilities can be acquired. Table 13 shows a comparison of the components that were considered for this project:

Table 13: Comparison of Current/Power Monitor Considered for this Project

Manufacturer	Texas Instruments	Texas Instruments
Series	INA231[19]	INA220 [16]
Input Offset(+/-)(Max)(μ)	50	50
Iq(Max)(mA)	0.420	1.0
Gain Error %	1	0.2
CMRR(Min)(dB)	100	120
Vs(Min)(V)	2.7	3
Vs(Max)(V)	5.5	5.5
Special Features	Alert Function Bi-Directional Low-Side Capability I2C	Bi-Directional Low-Side Capable I2C
Operating Temperature Range (C)	-40 to 125	-40 to 125
Price	\$1.15	\$0.99

We decided to go with Texas Instruments in to avoid worrying about compatibility with products of other companies. These two ICs feature current measurement in amperes and power measurements in watts. Even though we are planning to obtain an IC with integrated power calculations, that does not mean that we are rejecting the option of obtaining the current shunt itself and program a microcontroller to calculate the desired power. But for time sake, we decided to obtain the IC with the power calculation feature included. The preferred component is the INA231 because for a small price difference, some extra features, such as a lower Vs min contributing to our purpose of saving power; and also includes an alert function.

According to Texas Instruments, the INA231 performs two measurements on the power-supply bus of interest. The voltage developed from the load current that flows through a shunt resistor creates the shunt voltage signal that is measured at the IN+ and IN- pins. The device can also measure the power supply bus voltage by connecting this voltage to the BUS pin. The differential shunt voltage is measured with respect to the IN- pin whereas the bus voltage is measured with respect to ground. [19]

Shown in Figure 23 is the register block diagram where the measurements are processed. Note that (1) is Read-only and (2) is Read/Write

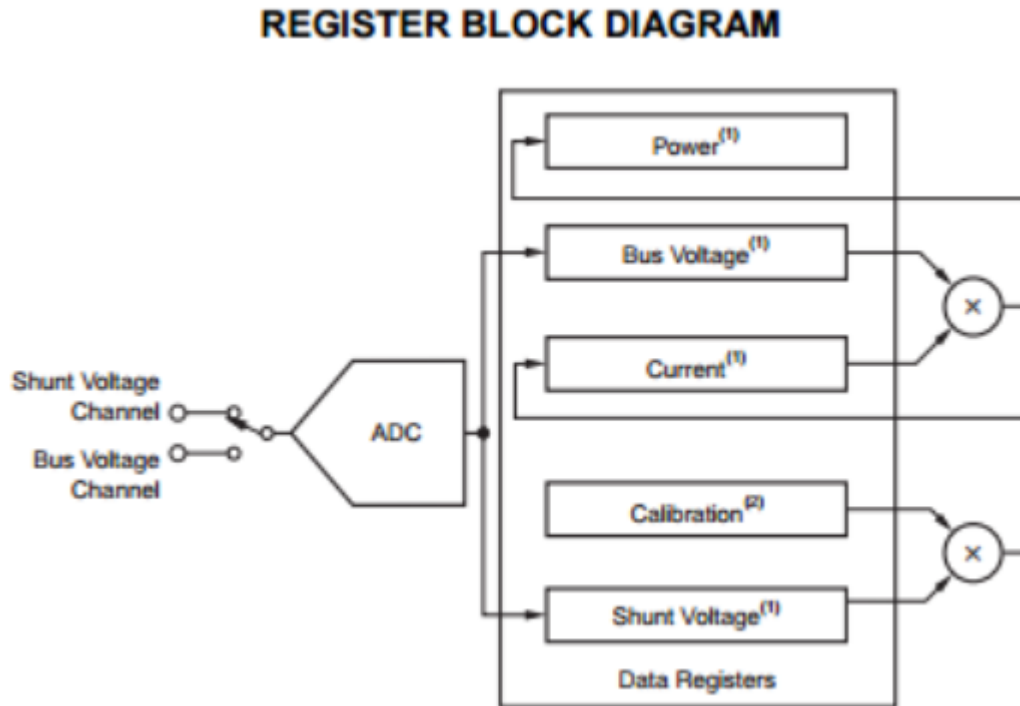

Figure 23: Register Block Diagram for INA231 [19]
(Image Courtesy of Texas Instruments)

The IC will be connected to the slave microcontroller in the power monitoring section, which will send via Bluetooth the information obtained to the master microcontroller in the main hub to be displayed in the LCD.

5.3 Software Design

The software design for the system for the microcontroller will be done in assembly. Assembly code is written from the perspective of the microcontroller itself. The code implementation is very basic, short coded syntax and compilation is a lot quicker. The type of assembly that will be utilized in this project is RISC (Reduced Instruction Set Computer) language. However, there are three other main types, CISC (Complex Instruction Set Computer), DSP (Digital Signal Processor) and VLIW (Very Long Instruction Word). The CISC architecture is, hence its name, a complicated assembly language to write in at times. The benefit of its syntax is that the amount of taken to code is a lot shorter. However, in the microcontroller, it will have to use many addressing modes which are hard to use at times. It does use a small amount of registers in order to save space, but saving instructions on the register is process since the opcode of an instruction is not easy to implement. Since the length of code is smaller, specialized instructions will have to be known by the user in order to perform the same duty as a longer piece of code would do.

Digital Signal Processor language. This language is designed specifically for signal processing program, not usually used for development on a grand scale since it is not a language that is widely known. In that case, the use of registers and opcodes will take longer to learn how to utilize and is not usually compatible with the msp430 for example which will be used in this project. The VLIW language is primarily used for more demanding devices. It is a heavily pipelined system so that allows many tasks to be running all the time. Thus, this does not allow for low power usage for a device. The language is not that user friendly for some developers and will also not be feasible for this project since this project focuses on a few tasks running and do not want a lot of program space to be used up in the memory. Therefore, the RISC architecture is more fitting with this project. The code is lot easier to work with since statements are very short and fairly easy to understand. It does not take up a lot of memory space and very good for complier usage. The msp430 designated for this project is a 16-bit RISC architecture. The operations performed in this microcontroller will be done quickly since syntax is short and uniform. In addition to using RISC, Code composer will be the IDE to write the assembly code. The nice thing about Code Composer is that it can create projects to start off a user's program and give tips for what syntax is used for what purposes. The debugger is very easy to use as the programmer can see what registers are being manipulated and be able to test the code and make sure certain values change as they are supposed to.

5.3.1 Microcontroller

As stated above for the purposes of this project, assembly will be used to program the microcontroller. Two microcontrollers will be used for this implementation the MSP430F6638 and MSP430F2013.

Now there are other languages that can be used to program microcontrollers such as BASIC, Pascal, C and C++. When choosing a programming language, especially for microcontrollers it is important to consider the features of the microcontroller and how the programming language will affect its function. Since the system is intended for easy implementation and low power usage, a low level language will be more efficient.

The microcontroller was originally programmed in assembly since it had a close relationship to the bios directly. But now higher level languages are able to program many microcontrollers. BASIC is very easy language to learn and used for simple programs. Since its purpose was to aid the average user in learning how to program, it became very popular among many. It has many built in functions which would help the programmer spend less time coding and compiles just as quickly as C does. Unfortunately, it is not a popular standard for microcontroller programming and its code does not transfer over to other processors well. Speaking of C, this programming language has become very instrumental in its implementation of building programs. Since it is a higher level language, it aims to compile code in a reasonable time frame. C has become so popular that many IDEs have been created to host this program and is capable of crossing other platforms. It has many built in functions that are pre-written to perform for certain functions like data retrieval, web sockets and for creating shell programs which operate at the bios level. However, it is hard language to learn and more memory storage is needed to process the program. C++ is an object oriented language in that it was developed similar to the C language. It is very a portable

language and a low level language as such as assembly. Its portable nature is beneficial since it can be implemented in other platforms for portability. It resembles the C so that programmers who migrate from C to C++ will not necessarily have to learn a whole new syntax. Again since it is a low level language, memory usage is not wasted and can operate directly with the processor. However, it does not have any security built in and it is not familiar among the group members.

Pascal was created based on the idea of creating an efficient language considering compilation speed and the amount of code that had to be written. The syntax of pascal is very easy to understand as it tries to use common words that make sense to human beings as such “Begin” and “End” and starting a function. However, it can be a bit wordy therefore as stated before only increases the time to write a program. Since it is a higher level language, the use of memory is used up a lot more similar to C. It is not as flexible as C since it is a more structured programming language that allows the flow of control to be mandated by standard statements.

With these in consideration, assembly was chosen because it is very familiar among microcontroller guides and coding is easier to follow. Even though it may not have as many built in functions as the higher level languages, compile time is faster and the does not take up as much memory in the microcontroller. Since the assembler is the base level of a processor, the programmer is able to change functions and perform actions at the root of the hardware and debugging is so much easier. With this in mind, assembly is also more familiar among the group which will help save time in coding and the syntax can access the registers of each component on the microcontroller a lot better as well. If using a higher level language, debugging may be a bit more difficult since they do not use assembly syntax which talks in registers and operand terminology which higher level languages are written so that the average user can understand functions in human terminology.

5.3.2 Dimmable Light System

The basic subsystem of this project is the light sensors. As previously noted, there are many types of light sensors that help in the regulation of lighting, external light source detection and lighting is regulated by the occupation of an area. This dimmable lighting system will be implemented into areas of the home that is mostly used by a user such as bedroom, kitchen, bathroom, etc. The basic implementation of this device is to detect motion and if motion is detected, the light will turn on. The microcontroller will be programmed using Code Composer v5 in order to program it. The functions used in the program will be send and receive functions in order to obtain data from the ambient lighting. This program will utilize assembly programming which aids in the use of less memory usage in the microcontroller and does not take up as much data storage space.

Dimmable lights need a dimmer in order for this to work. Many effective dimmers now use light dependent resistors in order to detect intensity of light. The old method was just using a plain old resistor that did not allow current to flow in a consistent manner. This then caused voltage levels to be low or inconsistent and not very efficient. The dimmer will be communicating through the microcontroller in order for the first step for it to turn on as follows [20].

The first part of this system is the light coming on. The figure below explains how the program in the microcontroller will have functions that will contain conditional statements to determine a

specific output. This light sensor will detect motion in order to be turned on. The sensor will utilize the PIR (Passive Infrared) technology in order to detect the difference in temperature between the surrounding environment and a moving object. The software controls the microcontroller's output pins and may utilize an LED to turn on to show the microcontroller is processing that instruction. The program sends a signal through the microprocessor and when it compiles through the conditional statement, will check if the light detects motion. If so, the light will turn on. Also, the conditional statement will instruct the microcontroller to check if there is no motion, then light will turn off. However, the system should not turn off the light instantly.

Therefore, a timer will be set in place to allow a certain amount of time to pass and if there is no movement between that time frames, the lights should switch to off. The timer function will determine when the light needs to be turned on/off according to the figure. For simplicity purposes, the timer would be easier to implement instead of programming a real-time implementation that tracks at times the home owner is not in the vicinity of the lighting system. Shown in Figure 24 is the Motion Detection Software Flowchart.

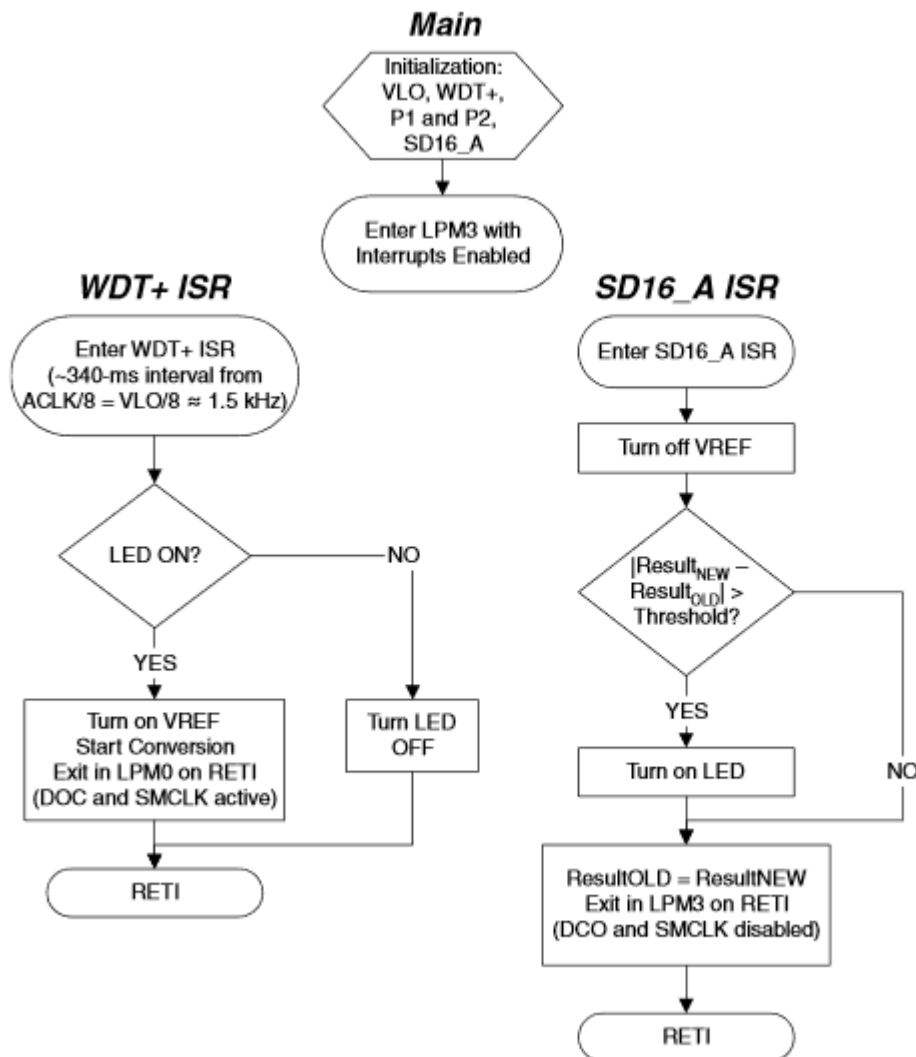

Figure 24: Motion Detection Software Flowchart [6]
(Image courtesy of Texas Instrument)

The second implementation is the ambient lighting. The ambient as previously stated aids the user in changing light levels depending upon the external environment. The following figures will demonstrate that process. It will take into account outside sunlight and without light conditions.

Again, the program will use a conditional statement in order to test if there is sunlight or darkness. The microcontroller’s program will implement a detect function in that the ambient light will detect and constantly measure outside light intensity from the environment. In order for this to occur, the sensor must be able to convert light intensity to a digital signal, so that that digital signal can be sent to the microcontroller. Table 14 shows the dimmable light required characteristics and Figure 25 shows the correspondent flowchart.

Table 14: Dimmable Light System Characteristics

Time of Day	Day Time	Night Time
If user is present in room	Send signal to lights to dim	Send signal to lights to output maximum power
If user is not present in room	Keep lights on off state	Keep lights on off state

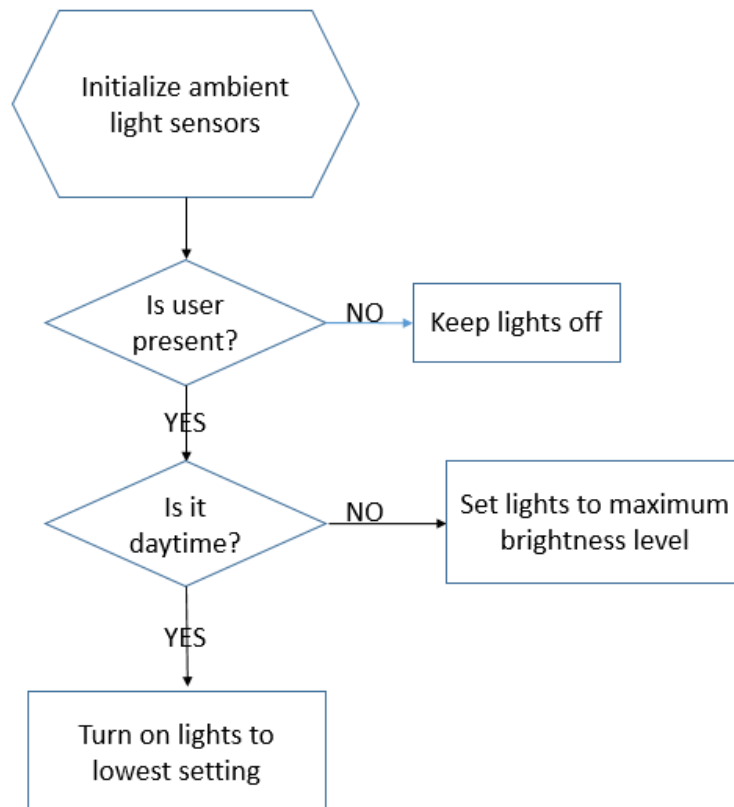

Figure 25: Dimmable Light System Characteristics Flowchart

Once that has been established, the conditional statement tests the input (the outside light) and the ambient light will dim if intensity is greater than the lighting system voltage. The same test

will occur when there is no outside light during the night time. The light will measure any light intensity coming from the outside, if there is no level detected, the signal will again be sent to the microcontroller's program and the conditional statement will once again run. Since there is no light coming from the outside, the program sends a signal to the ambient to set the lighting system to max output. This will aid the user in having to waste unnecessary power.

The program will run in a loop which instructs the ambient light to constantly check for external light intensity in order to dim properly.

5.3.3 Thermostat Compatibility

The second subsystem of the S.H.A.P.E.R. design is the air conditioning management system. AC has become a very prevalent reality in this day and age where outside conditions can be unbearable and users demand comfort when they go out to run errands in the home or in the community. For the home owner, the AC is a big power house especially in conditions where it is hot. The usage of this system can be inconsistent therefore causing electricity bills of the home owner to sky rocket. The following diagram steps through the following process to help solve this problem with home automation. Figure 26 display the thermostat compatibility flowchart.

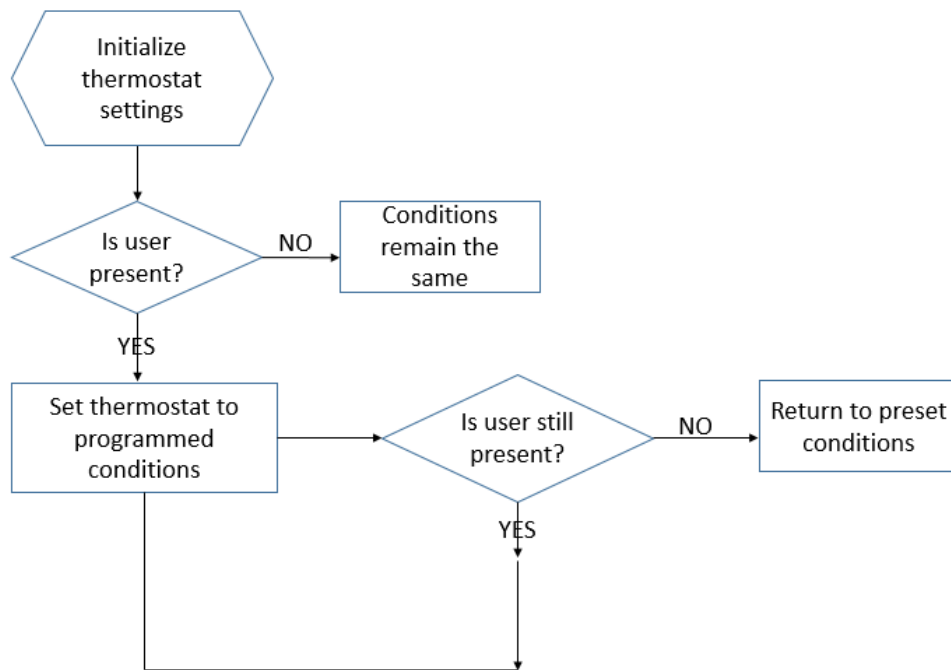

Figure 26: Thermostat Compatibility Flowchart

The software implementation will be made in the microcontroller. The microcontroller's program will be using conditional statements again for the air conditions. If someone is in the room, the PIR sensor will be utilized again in this manner to detect motion. But now, when there is motion detected, the microcontroller will instruct the thermostat to set the condition to a specified temperature setting. Again, it will be set at a temperature that is comfortable to the user but does not consume too much power. If there is no one in the room, the AC will be preset to a temperature designated by the program in the microcontroller to conserve energy. This is usually between 75-

85 degrees. The microcontroller program will then run through the conditional statement again to determine if there is motion in the room. In this case, since there is none, the microcontroller instructs the thermostat to set the air condition that is stated in the assembly code.

The advantage of this process is that the user will not need to keep changing the temperature in the home unnecessarily. The thermostat's programmed conditions can be changed by the user in case the conditions that were considered comfortable at that time is no longer valid.

5.3.4 LCD Interface

For the system interface, users today are really into the touch screen interface technology because of its elegant look and user friendly implementation. The use of the LCD will not allow the user to change the temperature of the home is needed but it will also display the power consumption that the home owner is using.

The main benefit of this implementation is, again, to help the home owner be more aware of the devices that use more electricity and cognizant of their power usage of their devices as a whole. The microcontroller will use an algorithm to calculate the amount of power a single device uses. Since power is proportional with current and voltage, the algorithm will calculate and multiply these two values. Since the current coming in will be alternating current, the power value will be based off an rms voltage and current.

At the basic level, the microcontroller will only set the conditions of the home based on the program. But if the user needs for some reason to change the preset conditions, the microcontroller will track these differences and reset the previous condition to the user's new preferences. The interface will have up/down arrows that will allow the user to update the temperature at will if necessary. The microcontroller will be programmed to interface with this to set conditions to normal conditions when the home owner is not present. This interface will be user friendly to provide comfortability and less headache for the user. This will be useful for the user to look at the data in case they are not near their smartphone.

5.3.5 Bluetooth Remote and Sensor

As stated before, Bluetooth implementation would be preferred for this project because of the simplicity of using this technology. The Bluetooth sensor will not only be utilized on the microcontroller process to connect to the light system, it will also be a gateway for the microcontroller to communicate with the air conditioning unit for the user's convenience. The Bluetooth sensor can be used in case access to wireless data is terminated for a moment, such as from a router.

Since it is low powered and sends out weak signals, it does a very good job of not interfering with other signals that may be lurking in the owner's home. When two or more signals interfere, noise is created thus distorting data transmissions and access to information is skewed. Devices that are within a short distance can utilize Bluetooth as well since it does not need a router or wires to access data. However, since speed transfers are not as fast, the user can use this when he/she is not in a hurry. The Bluetooth sensor will be implemented in a remote on the microcontroller that can be near devices that utilize the pairing mechanism.

The advantage of the Bluetooth is that it can connect at least 4 devices simultaneously. For the S.H.A.P.E.R. project this will be beneficial for the user so that they do not have to have more than one Bluetooth remote in order to reduce cost. The technology used for this will be Bluetooth 4.0 or otherwise known as Bluetooth Low Energy (Bluetooth.com). [21]

Bluetooth 4.0 is very power efficient. The benefit of this technology is that it is very applicable to devices that need to continue to run for a vast amount of time. As discussed originally, it is more applicable to Internet of Things. For the Internet of Things, this version also allows for high security features with a 128-bit AES data encryption (Bluetooth.com). It also is developer friendly as well in order to help programmers be innovative in their design. For our system, the application for the smart phone that will be discussed later is a great fit for this technology and is flexible. The following diagrams show the flow of control for the Bluetooth functionality. To program the microcontroller, the Bluetooth sensor will contain an API structure in order to allow the microcontroller to search for paired devices. The API will have to be developed from scratch since assembly language does not have built-in functions for wireless protocols. The UART functionality that allows the microcontroller to communicate via a terminal would be best suited for this implementation. Figure 27 shows the Bluetooth remote and sensor flowchart.

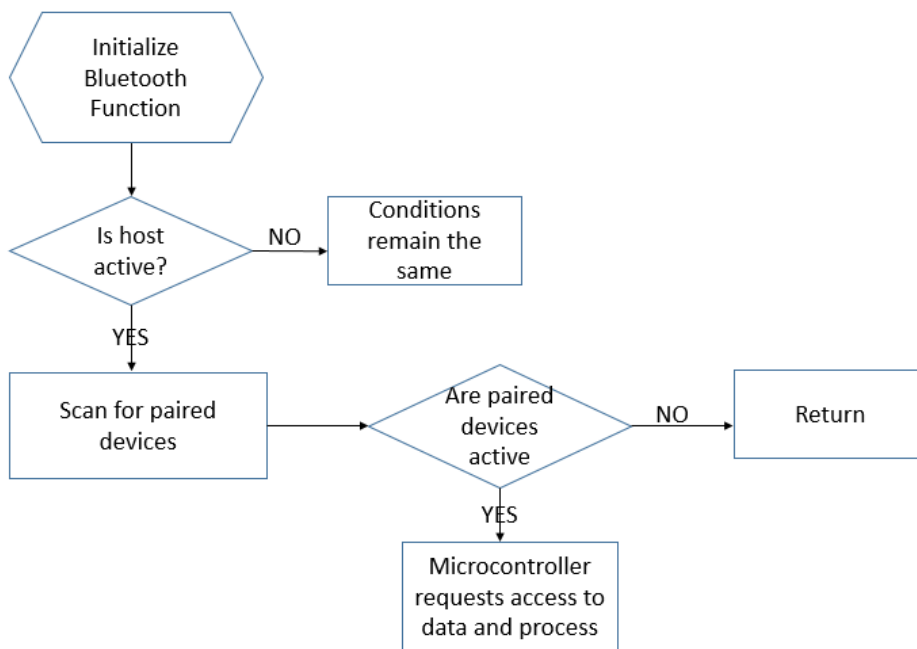

Figure 27: Bluetooth Remote and Sensor Flowchart

5.4 Additional Design Components

The principal hardware components for the central hub were discussed in section 5.2. Moreover, the software design of the central hub was also discussed. However, our project features some other components that are also important to obtain the most accurate possible functionality of the

circuit. Therefore, the following subsections will describe the structure of each one of the elements, and the role they will be playing in our design.

5.4.1 Dimmable Light Bulbs

The dimmable lighting system will act like an output in our project because according to the information obtained from the microcontroller regarding the amount of light in a room and if there is a person in it at the same time, the lighting system will be turned ON and the lights' brightness will be adjusted accordingly. In addition, we want to prevent flickering. Moreover, we want the light bulbs to be able to dim progressively, so they can be programmed to follow the preset values according to the light detected by the ambient light sensor. Another factor that is important for our project is the amount of power consumed by the appliances, in this case, the light bulbs are considered also appliances; therefore, we need also to select bulbs that have a low power consumption. In addition to this, we also need a relay in order to control the current flow that will be passing into the appliance. Our project is considering not to include a wall mounted phase dimmer, instead, we want to be able to control the dimming phases using the microcontroller and the android application, the latest will be discussed in section 5. . Different types of light bulbs were considered: halogen, incandescent, LED, etc. After further research, we decided to use LED dimmable light bulbs because they are more energy efficient than any of the other products available in the market.

Taking into account the required functions of the needed lighting system, we need to choose light bulbs that are able to meet these specifications. Therefore, shown in Table 15 is a list of the desired characteristics:

Table 15: Desired Characteristics for the Dimmable Light Bulb used in this Project

Characteristics	Desired Value
Dimmable Range (%)	100% to 10%
Life	30,000hr
Flicker-free	Yes
Power Consumption	≤12W

A comparison of some of the dimmable light bulbs considered are displayed in the Table 16:

Table 16: Comparison of LEDs Dimmable Light Bulbs Considered for this Project [22]

Manufacturer	TCP	Philips	Sylvania	GE
Series	A19	A19	A19	A19
Power	7W	10W	8W	9W
Dimming	100%-5%	100%-10%	100%-10%	100%-5%
Lumens	450	475	390	450
LPW	64.0	59.0	48.8	50.0
Life	50,000hr	50,000hr	50,000hr	50,000hr
CCT	2700K	2700K	2700K	2700K
CRI	85	92	85	82
Voltage	120V	120V	120V	120V
Price/Vendor	\$9.97/Amazon	\$12.51/Amazon	\$7.98/Lowe's	\$9.99/Walmart

After carefully reviewing the features present in the previous LEDs dimmable light bulbs, we have decided that the product that best suits our needs is the TCP A19 (7W) dimmable light bulb. It has a low power consumption of just 7W compared to its incandescent equivalent which is 40W, a reduction in power consumption of more than 80%, which is perfect for our project. Moreover, this bulb has the capacity of dim from 100% down to 5%, which is also very beneficial for the design because we wanted a bulb that could be dimmed down to 10%; however, if we can dim it to more or less 5%, then more power can be saved. Lumens refer to the measurement of the total “amount” of visible light emitted by a source; for 40W, which is the incandescent equivalent of the selected bulb, the estimated measurement is 450 lumen or lm, so our item produces exactly the estimated amount. LPW refers to the lumens per watt, which is how efficiency is determined in lightbulbs, the more the LPW, the most efficient the lightbulb is, meaning the more light obtained for the same amount of money. The product we chose has the highest value of LPW suggesting that it has the best efficiency among all of the other products. The estimated life of the bulb and the Correlated Color Temperature (CCT) of all the items are the same. Moreover, we also based our decision in the Color Rendering Index (CRI), which is a scale from 0 to 100 percent indicating how accurate a "given" light source is at rendering color when compared to a "reference" light source. The higher the CRI, the better the color rendering ability. In this case, a CRI of 85 to 90 are considered good. [23]; therefore, our lightbulb falls into the good category. Finally, the price is affordable and compared to the price of the other products, there is not really a big of a difference among them. Moreover, these bulbs are shatter resistant and they have no ultraviolet (UV) light, so they will not cause fading. In addition to the previous features, these bulbs are also ANSI construction compliant, which means that they can be used in applications where the traditional incandescent bulbs are used. Some other specification of this product include: input line frequency of 50/60 Hz; maximum starting temperature of -30°C; and a maximum operating temperature of 40°C.

5.4.2 Ambient Light Sensors

The ambient light sensors are the ones that will give the information about how much light is being detected in the room when someone is present in the room. With the information obtained from the sensors, the microcontroller in the central hub will process the data and it will send a signal to the circuit in the dimmable light bulbs and according to the amount of light in the room, the bulbs will be turned ON to a specific brightness setting. There are three types of ambient light sensors

devices that we considered for our project: one made of photo resistors, one made of photo diodes, and one made of photo transistors. In order to select the component that complies with our requirements, a list containing the desired characteristics is shown in Table 17.

Table 17: Desired Characteristics for Ambient Light Sensor used in this Project

Characteristics	Desired Value
Low Power Consumption	Yes
Integrated Noise Reduction	50/60Hz
Power Supply	3V
Interface Peripherals	I2C

We will be utilizing photodiode photosensitive ambient light sensors. After a further research, we found a vendor that offers the sensors with the described characteristics. However, there are many series to choose from. Therefore, Table 18 shows a comparison of some of the products that we felt fit our design:

Table 18: Comparison of Ambient Light Sensors Considered for this Project

Manufacturer	Intersil [24]	Intersil [25]	Intersil [26]
Series	ISL29020	ISL29023	ISL29034
Power	2.25V to 3.3V	2.25V to 3.63V	2.25V to 3.63V
Peak Spectral Sensitivity	540 nm	540 nm	550 nm
Operating Temperature Range	-40°C to 85°C	-40°C to 85°C	-40°C to 85°C
Supply Current	55µA	85µA	57µA
Integrated Noise Reduction	50/60Hz	50/60Hz	50/60Hz
Serial Interface	I2C	I2C	I2C

Although the characteristics of these components are very similar, we decided to use the ISL29020 because of its low power consumption characteristics. So, in general this module can be connected to our main microcontroller through the I2C serial interface. In addition, the ADC in the device is capable of rejecting 50 to 60 Hz of flickering that may be caused by artificial light sources. Moreover, it has a low power consumption, and it also includes two power-down modes in order to reduce more the power consumption if it is necessary. If polling is chosen over continuous measurement of light, the auto-power-down function shuts down the whole chip after each ADC conversion for the measurement. The other power-down mode is controlled by software via the I²C interface. The power consumption can be reduced to less than 1µA when powered down.

5.4.3 AC Thermostat

The thermostat will be able to be directly used by the user and the microcontroller. The goal for this system is to be controlled via the MSP430. The thermostat itself is already implemented in a microcontroller used for developmental purposes. The more popular types of the thermostat is a digital electronic device. It uses thermistors to allow the device to sense temperature in the

environment. One microcontroller that can allow perform this application is the MSP430FR4133 provided by Texas Instruments. This device is ultra-low power for efficiency and has a lot of peripherals. According to the Texas Instrument User Guide for this device, this device has the following features:

Ultra-Low-Power, LCD interface, FRAM memory, Capacity touch for the touch screen capability, ADC module. [27]

The LCD interface will be discussed in the next section but the capacitive touch screen and fram memory will be very helpful for this design. The user will not only be able to use this to monitor and change temperature, it also has a wireless support feature so that temperature can be changed via Wi-Fi or possibly Bluetooth.

Figure 28 shows the diagram of how the board looks likes, and Figure 29 is a detailed pin layout for the MCU.

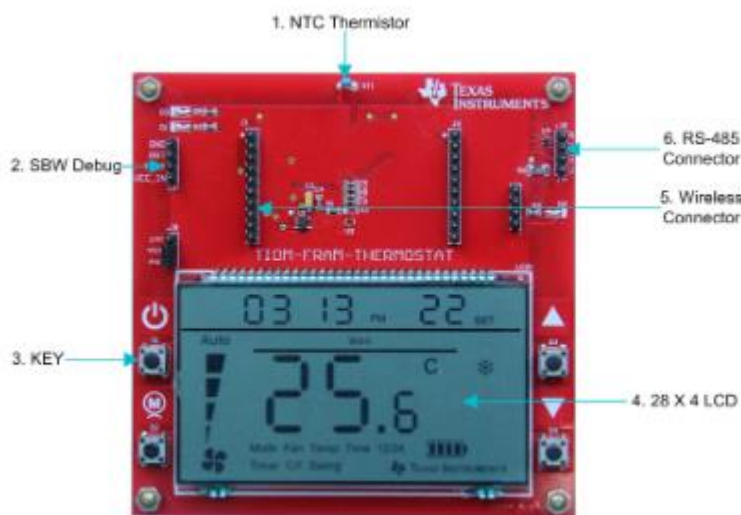

Figure 28: Basic AC Thermostat Board [27]
(Image courtesy of Texas Instruments)

It has a FRAM-based MCU with 15.5 kB of nonvolatile memory according to the user guide. The following diagram shows the pinout and the many peripherals as mentioned before [27].

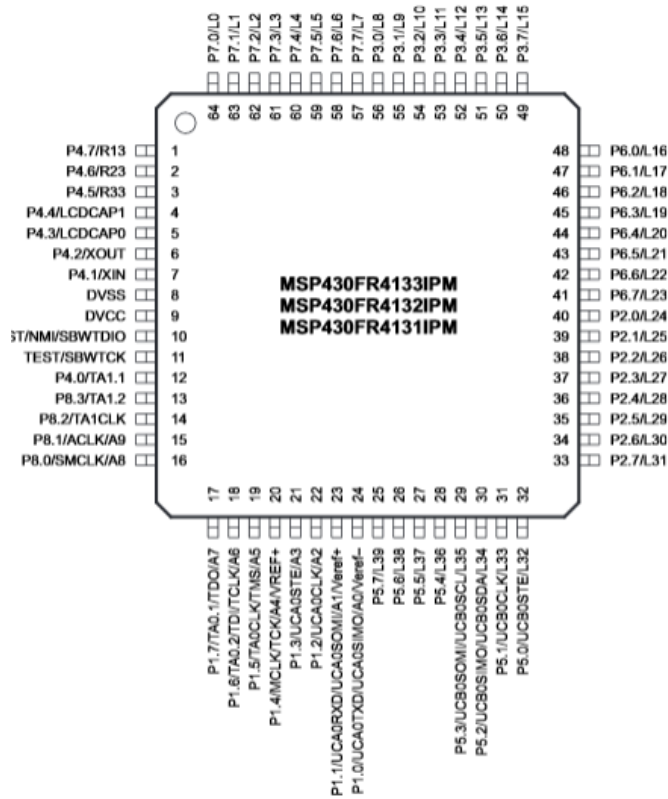

Figure 29: Pinout for MCU [27]
 (Image courtesy of Texas Instruments)

The abundance of pins will allow the programmer to be able to consider which peripherals would be needed in order to the user to directly manipulate the thermostat settings and how to connect the central hub MSP430 in order to communicate with. Since the RS-485 offers wired or wireless data transmission, it will be useful to implement and consider the diagram shown in Figure 30.

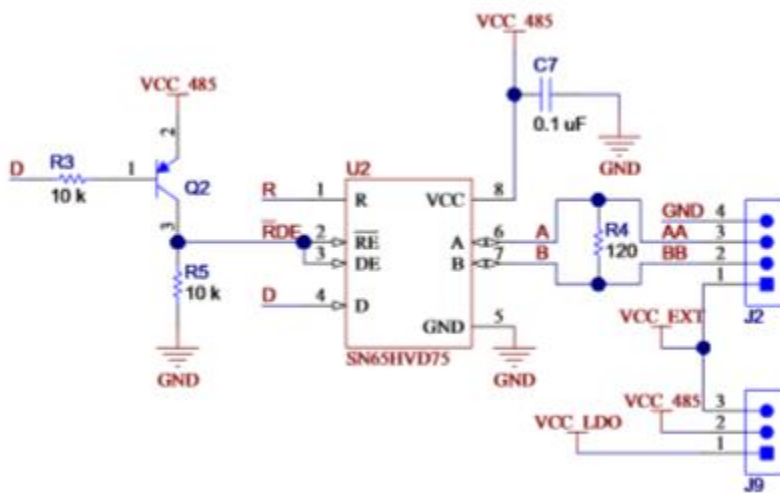

Figure 30: RS-485 Circuit
 (Image courtesy of Texas Instruments)

5.4.4 LCD Screen

Considering the same microcontroller, the LCD interface is designed in a such where temperature, weather conditions, the time fan speed are easily noticeable as shown in the Figure 31.

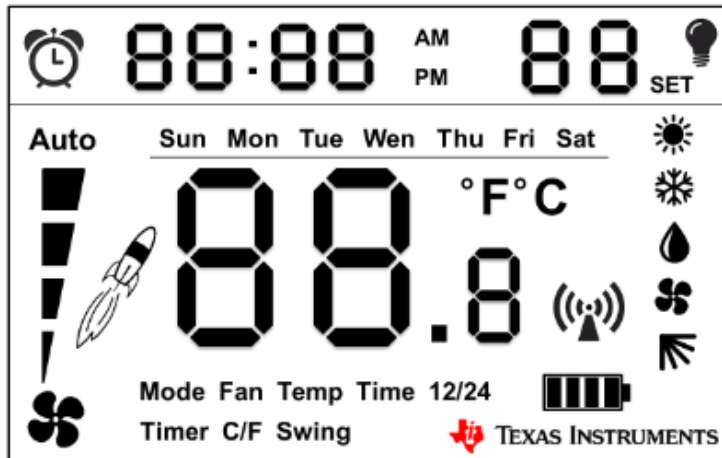

Figure 31: Basic LCD Screen Interface [27]
(Image courtesy of Texas Instruments)

The LCD interface design is already implemented in that there are capacitive touch buttons that can be used to program the thermostat to its temperature settings.

5.4.5 Relay

A relay will help in the control of the flow of current connecting between the power source and the appliance utilizing the power source. Since the microcontroller is small, the size of the relays will not need to be as huge. Relays tend to deteriorate after a certain time since a number of springs and links that can break down. The benefit of using a relay will be easy to construct and will not need programming to get it to work. It is solely an electro-mechanical in design. A reed relay is applicable to this project since it is able to switch a lot faster than larger relay systems. They also do not require a lot of power and have low switching current and voltage ratings.

5.4.6 Lead Battery

Batteries are great source of independent power especially for systems that are portable. The battery can help with designing applications that are small in size and functionality. The battery will be able to deliver a majority of its capacitance which is usually on a daily basis. The implementation of this is helpful for the testing purposes of supporting the microcontroller.

Out of the power sources that were discussed, the lead acid battery was deemed the most viable option for the S.H.A.P.E.R. project. A type of lead acid battery is the VRLA or Valve Regulated Lead Acid Battery. This battery is sealed in order to allow safe escape of hydrogen and oxygen when it is recharging. The lead acid battery will offer a low energy feature and can supply high current and high energy densities. Since our system needs to be manageable, especially the power

source since if something goes wrong, it will not have to be of great significance to worry about since the lead battery is a low maintenance entity. The battery will be most likely mounted onto the printed circuit board or left isolated for testing purposes. Since it is a direct current component, its power will have to be converted to alternating current since most homes use this standard volt rating.

5.4.7 Power Inverter

The function of the power inverter is to convert 12 VDC from the lead battery into 110 VAC. Since we want to create an AC voltage in order to provide energy to the circuit, we considered using either a modified sine wave inverter or a true sine wave inverter. After further research, we decided to select an AC modified sine wave inverter because it use will not affect the functioning of the microcontroller or any other part of the circuit. Moreover, price wise, it is more affordable than a pure sine wave inverter. In our case, we need an equipment that has at least three outlets in order to connect the desired appliances and in order to power both subsystems of the project. Therefore, some of the characteristics desired our displayed in Table 19:

Table 19: Desired Characteristics for the Modified Sine Wave Power Inverter

Desired Characteristics	Desired Value
Peak Efficiency	$\geq 90\%$
Life	30,000hr
Power Consumption	$\leq 12W$

A comparison of some of the dimmable light bulbs considered are displayed in the Table 20:

Table 20: Comparison of Modified Sine Wave Power Inverter Considered for this Project

Manufacturer	Kisae [28]	Samlex [29]	Samlex [30]
Series	MW1210	Sam-250-12	Sam-800-12
Power(Continuous)	1000W	250W	800W
Power(Peak)	2000W	500W	1600W
Voltage/Frequency	120VAC/60Hz	115V/60Hz	115VAC/60Hz
Peak Efficiency	90%	90%	90%
USB Port	Yes	Yes	Yes
Voltage (Nominal)	12.5 VDC	12.5V	12.5VDC
Price	\$99.00	\$24.89	\$60.27

The power inverter is needed to convert the DC voltage from the lead battery into AC voltage in order to power our circuit. In our case, we will choose the Samplex Sam-800-12 power inverter because we will be getting this component just for prototyping purposes; therefore, we do not need a power inverter with higher power rates. The appliances we will be utilizing while testing our design should not consume much more power than the one administered by the source.

5.5 Mobile Operating System Design

To control the system, we will need an operating system that will be the best at regulating our system's environment. We have compared the possible operating systems and we have felt that proceeding with the android OS will be our best choice. A thorough comparison was made between the android OS and other operating systems and the android is the best operating system to meet our needs. Our android application will be a crucial part in controlling the system.

5.5.1 Android Selection

We had the choices of multiple mobile operating systems to choose from for our mobile operating system. We narrowed our choices down to android and iOS to be selected for our mobile operating system. From the initial research that we gathered, the android and iOS were the most appealing choices. They each have aspects that would be appealing to S.H.A.P.E.R. There are many aspects that went into the choice for our mobile operating system. We created comparative benchmarks to help us decide which mobile operating system was going to be the best for us between the android and iOS.

An important benchmark to look at would be the popularity of the operating system. This would affect the reach that the application we developed would have. To measure the operating systems popularity, we would measure the operating systems share of the market and the number of applications it has available. Another important benchmark would be the operating systems reliability. We would look at the maximum crash rate that each operating system could potentially have. How we would create the application will be the next set of important benchmarks. We compared the cost to develop our application, what software developments tools would be needed, the internal operating system, and what languages the program would have to be written with. We compared the ability to add customizations, this is so that we could make changes if we felt were necessary. We final looked to see which operating systems for mobile devices supported voice control, as we may potentially have that as an optional method of user input into the system. The results we accumulated of the benchmark comparison are compiled in Table 21 that we have soon below.

Table 21: Android Vs iOS Comparison

Benchmark	Android	iOS
Global share of market	81.5%	14.8%
Applications available in market	600,000 from Google play.	700,000 from the Apple app store.
Programed using	Developers will be able to program using C, C++ and Java.	Developers will program mostly using Objective-C.
Development costs	It is free to develop with a onetime \$25 charge to publish.	It is \$99 per year to develop and publish.
Voice control	Google now is used to control the device with voice.	Siri is used to control the device with voice.
Availability	Variety of devices will support this OS.	Limited to apple products
Crash rate	Highest crash rate that can be noted is 1.7% from the Android 2.3 Gingerbread.	The highest noted crash rate is 2.5% from the iOS 5.
Customizability	Very customizable to fit developers need.	Not very customizable at all.
Operating system	Uses Linux inside the device.	The device uses OS X and UNIX.

(Created with information from [31])

In the end, the android won in our choice for mobile operating system. It excelled the apple iOS in almost all of the benchmarks we deemed the most important in choosing our mobile operating system. We took into account the market share that each operating system had. Android held 81.5 percent of the market while iOS only held 14.8 percent of the market. We would like the expense reducing advantages of the smart home automated power expense regulator to reach a large number of potential consumers, so the android definitely gets high consideration because of this aspect. The Apple app store has over 700,000 available apps while Google play has over 600,000. This may seem like a loss for the android, however the lower amount of apps may mean a less likelihood of us coming across competition with competitive apps if we ever chose to publish. The development costs for the android device are absolutely free. The only cost that may be acquired is the cost of registration to developers who desire to publish what they created, which is \$25. The android SDK is free and available across most platforms. IOS developers must pay an annual fee of \$99 to use the iOS SDK and be allowed to publish to the Apple app store. The crash rate of the android has a lower maximum crash rate than the apple iOS. This is more appealing to us so that we may avoid errors in the future. Each of the devices both support voice recognition in case we desire to utilize that in the future as an input to our system. The android is more customizable. This will aid us if we need to make changes to fit the design of our application. [31]

5.5.2 Android Application Designing Software

Along with choosing the android as the operating system for us to create our application. We have chosen to use Android Studios as our choice for developing our mobile application. We are going to be creating a lot of information for the development of our fully functioning application. The most valuable aspect of Android Studios, is that it will further bring organization to the design of our application. We will be able to store our work in packages, project files, tests, and productions. Some of these are offered in other development software we considered such as eclipse, but Android Studios has more attributes we felt could be offered to us. We will need to know how much computational resources the application we create is using up. Android Studios will allow us to use a memory and CPU monitoring tool to view the performance of our application. Configured “lint” and other IDE inspections will run when a program is compiled to further verify the execution of our developed code. In Android Studios, full issue explanations are displayed when hovering over a problem section of code to ease the developer with correcting things that need to be fixed. We want to make our code easily readable for those who may want to view the code in the future and for when we return to the code to make changes. Android Studios will allow us to easily annotate parts of the code such as return values, variables, and parameters. Android Studios will allow us to utilize a dynamic layout preview that will ease us in the conception of our application. We can use this to add elements to our design without mistakenly doing away with something we created that was desired. [32]

5.5.3 Android Application Design Logic

When developing the application, we have to first design a plan for how the coding is going to be implemented. This will help us to have an idea of what functions we are going to need and what logic we are going to use. After doing that, we will just code to implement the previously designed logic. In this section, flowcharts are utilized to explain the design logic that our system will have. We explore the design logic for the most important and complex aspects of our applications implementation. We will first be looking into the nature of the initial home screen when entering the application. This screen is not the most complex, however it is extremely critical because if it is improperly designed, the entire application will not function properly. We will then take a look at the power monitoring design logic. This will be the most complex system we will have to implement. The most computation will be conducted in this portion of the application, so it is very crucial that the design logic is mapped out beforehand. We will then develop the logic for the lighting control of our application. The lighting control will be what really showcases the effectiveness of our design. We will finally look at the logic for the cooling system of our application. The logic for the power tips and estimated power bill will be simple as it will mostly be information displayed to our users.

5.5.3.1 Home Screen Design Logic

The home screen we are developing with Android Studio will be the gateway to all the other sections we want to display to our user. It will be the glue that holds the different aspects of our project application together. The home screen will need to utilize little information from the microcontroller connected to the hardware. Upon entering the home screen, different buttons will be displayed to the user to decide on where in the application to send the user to. We will

continually check to see if a button has been pressed to leave the home screen and if not, the options for the user to choose from will continually be displayed. The logic behind this concept is not too complex but it is important that it is done correctly. A flow chart depict the design logic for our applications home screen is depicted in Figure 32 below.

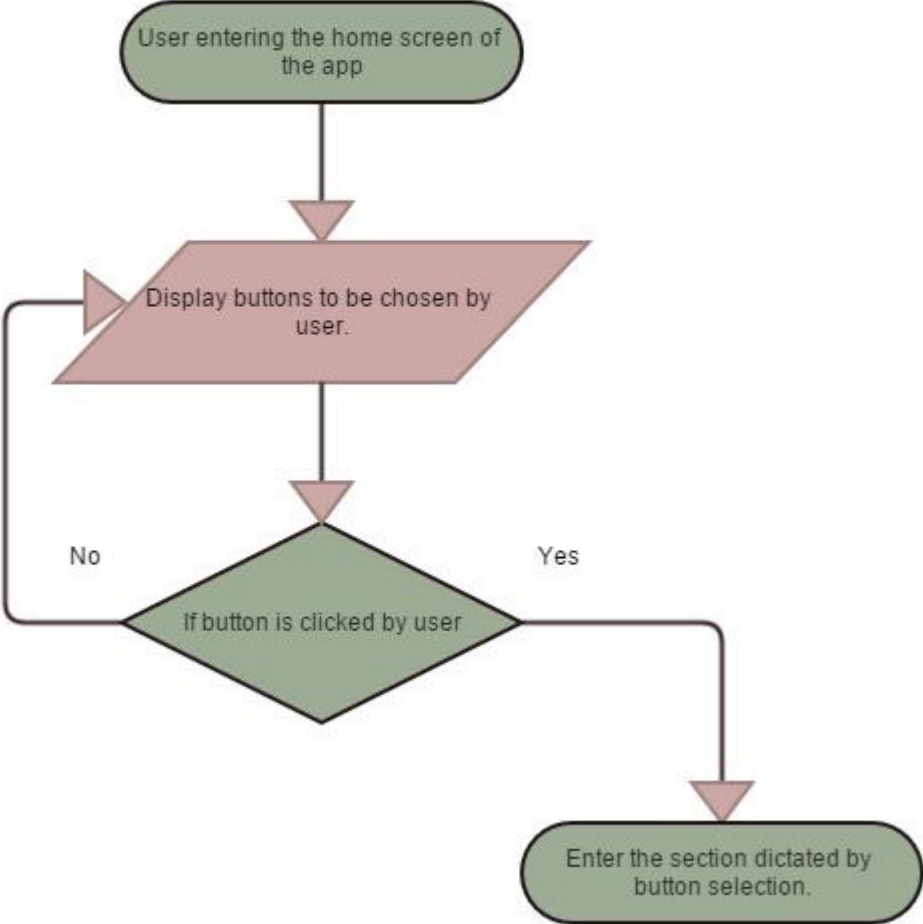

Figure 32: Home Screen Design Logic Flowchart

The home screen will represent the “main” section of our application, holding the key to the other sections within it. You can see the simplicity of this logics design. While we could add more complexity too it, we felt it was necessary to keep it manageable. This allows for less chances of errors happening in this portion.

5.5.3.2 Power Monitoring Design Logic

The power monitoring portion of our application will take up the most computation. It will be using data, from the microcontroller attached to the hardware, regularly. It will continually display the amount of power being consumed by the user. This section will continually need information coming from the microcontroller. The user will also have the option of having the information he desires depicted to him in graph form. This means the information will have to be compiled and

formulated at the user's request. Below, in Figure 33, is a flowchart depicting how the logic of our design, for the power monitoring application section, will unfold.

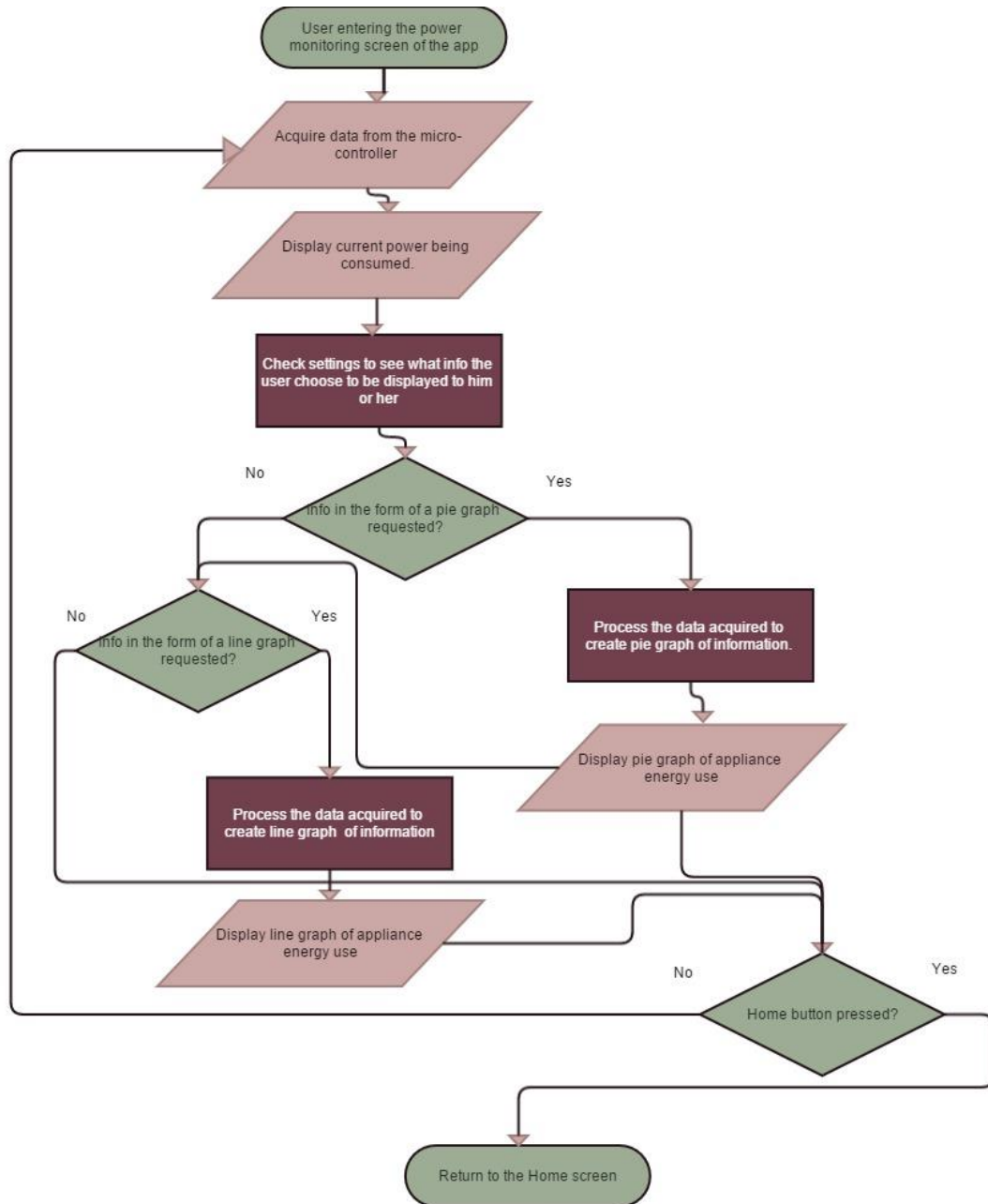

Figure 33: Power Monitoring Design Logic Flowchart

The power monitoring application screen will continually gather information from the microcontroller until that section is exited.

5.5.3.3 Lighting Control System Design Logic

The lighting system interface will not be as complex as the interface for the power monitoring, but it will be just as important. Information will be gathered to assess what the state of the system is and the user's settings. We will need to design around whether the user has entered the room and the amount of ambient light in the environment. We will also keep in mind that whether the user desires to manually adjust the levels of the light will take priority to whether there is ambient light in the environment or not. So our application would have to assess that first. The design logic of our lighting control section is shown in the Figure 34.

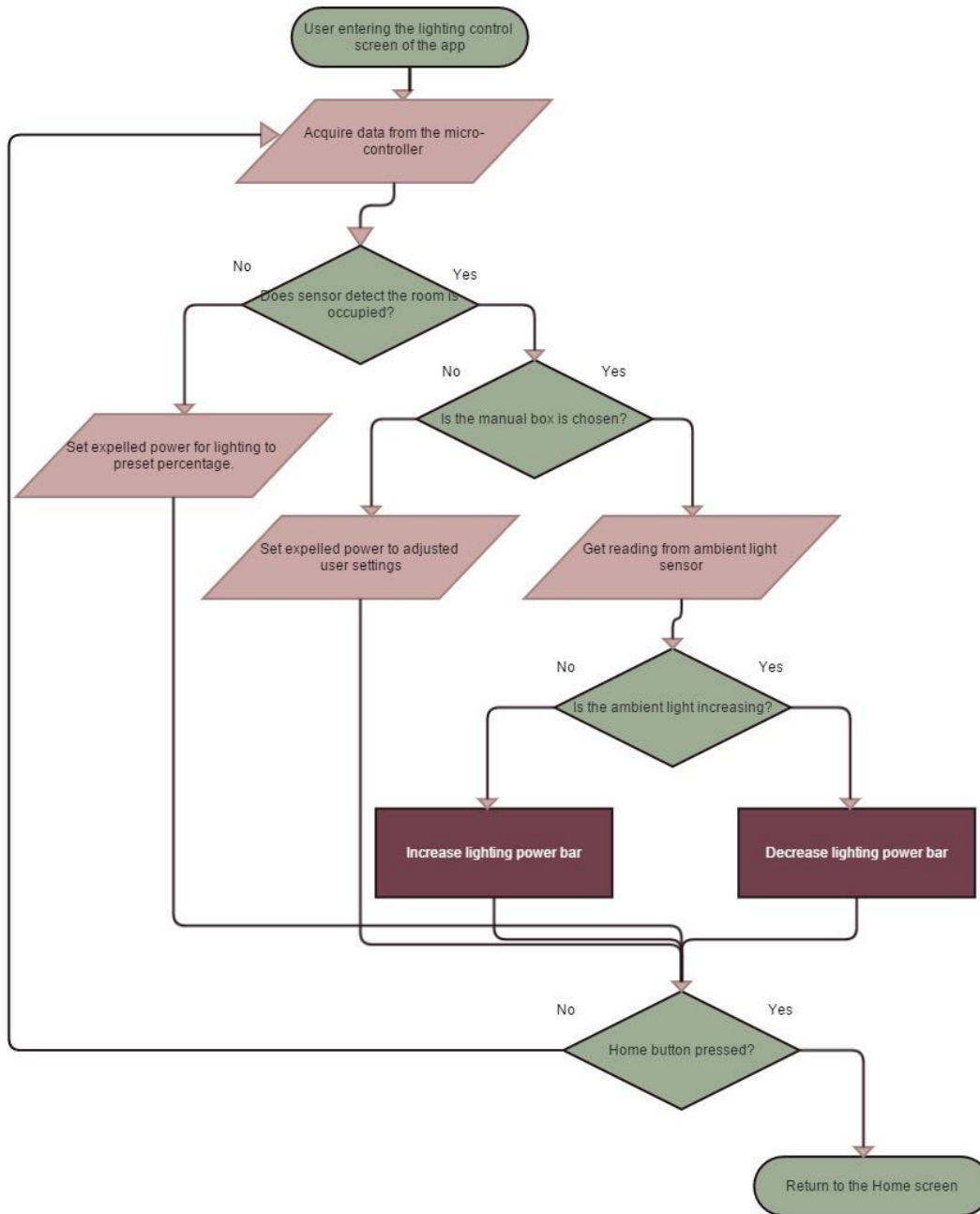

Figure 34: Lighting Control System Design Logic Flowchart

In our design for the software for the lighting control application, we wanted to make sure every scenario could be accounted for. Full control of the possible options is given to the user.

5.5.3.4 Cooling Control System Design Logic

The design logic of our Cooling control section will require less computation than the section for the lighting. We will continue to communicate back and forth with the microcontroller. The data concerning the state of the thermometer temperature reading will be coming in. The user will have the option to change the desired temperature directly and therefore the state of the occupancy of the room will need to be known. If there is occupancy detected, a signal must be sent to the microcontroller so it can set the temperature of the thermostat. If there is not occupancy in the room, the microcontroller will need to have the desired temperature for the unoccupied setting sent to it. The thermostat will then take on that value. The application logic must check if the home button was chosen to leave the section. If not, the data from the microcontroller will continue to be gathered. The design logic is shown in Figure 35 below.

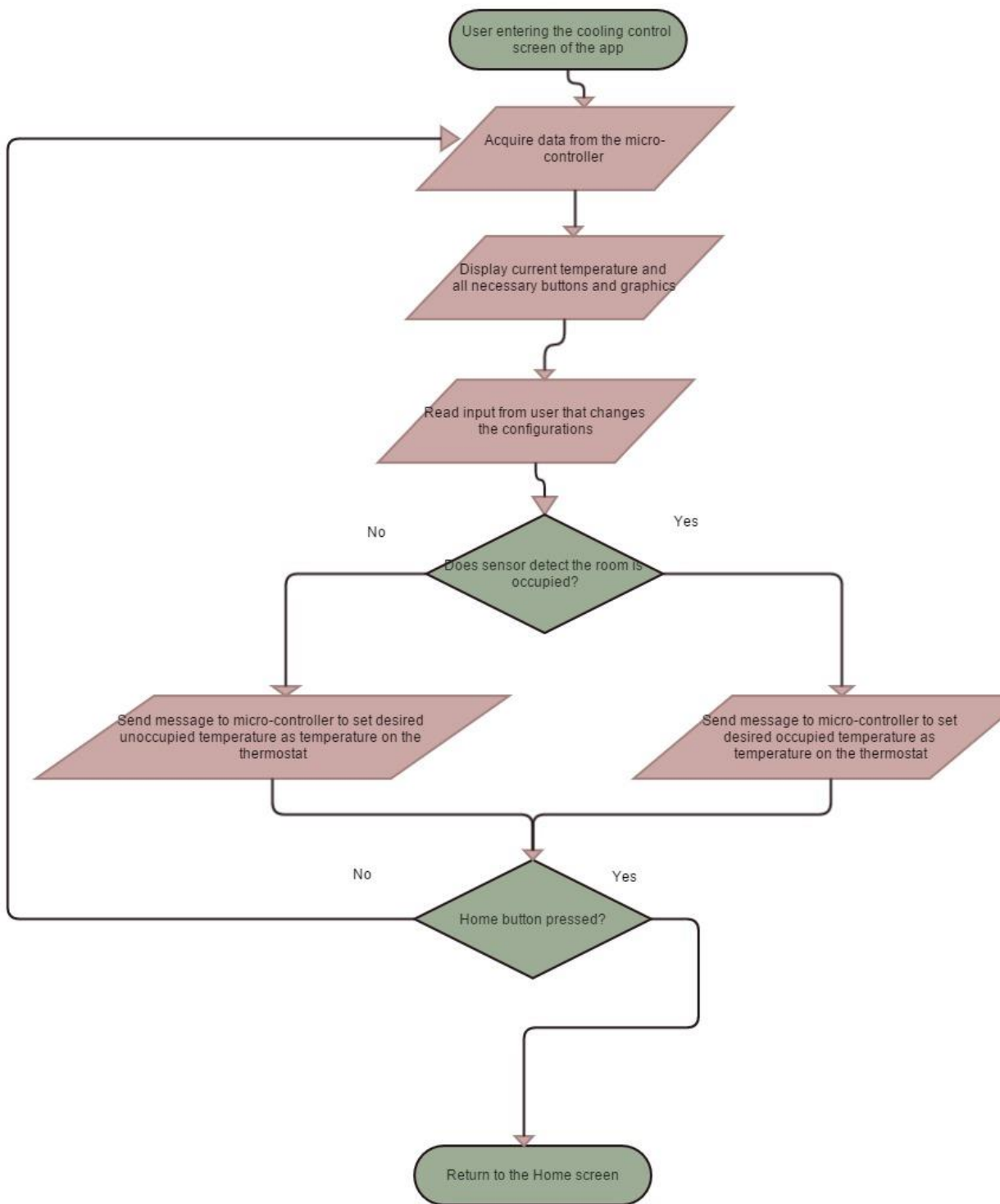

Figure 35: Cooling Control System Design Logic Flowchart

6.0 Project Prototype Construction and Coding

After a detailed description of the hardware and software architecture, the system needs to be prototyped so we can test it. This section will be divided in three parts: The Hardware Prototyping, Software Prototyping, and Android Prototyping. An explanation of how we planned to build the design can be find as follows.

6.1 Hardware Prototyping

After finalizing all the research and the selection of the parts, the team is ready to start building a prototype of the desired design. For that, all aspects of the design details and of the hardware will be taken into consideration in order to obtain successful results. However, the S.H.A.P.E.R is a home automation system and for that reason, prototyping and testing the original design with real appliances like washer/ dryer, water heater, and refrigerators, may not be feasible. However, we will make sure that the effect of power consumption by those big appliances can be tested in a small scale prototype. Since having all the components of a home is not really practical when it comes to prototyping and testing for a school project, our team is planning on create a wooden display and assemble the entire circuit inside it, in order to make all the features of the design accessible in an enclosed and relatively small space.

6.1.1 Power Supply Components

The first thing to do is to create power for the system to work. Therefore, the power inverter will create the AC voltage needed to run the whole circuit. In this case, a lead battery will be the DC power supply for the system. Once the system is ready to be powered, we can start thinking to start building the central hub.

6.1.2 Central Hub

As stated before, the central hub is the “brain” of the project. It is where all the information will be collected by the main microcontroller and the required output will be handle according to the project specifications. Therefore, having the main circuit built is the first step in the prototyping process. For that, the PCBs need to be acquired, so the needed parts can be properly mounted and tested; the testing topic can be found in section.

6.1.2.1 PCB Vendor and Assembly

PCBs are the most important part of our design because they hold together all the components of the circuit. If something goes wrong when printing the circuit board, the whole project will be jeopardized. Therefore, it is important to contact a vendor that satisfices our needs without compromising the quality and delivery time of the PCB. Since we need more than one PCB, this section will cover the making of all of the required ones. Four circuit boards need to be printed: main hub (1) and power monitoring nodes (3). Even though there are many PCB vendors in the industry nowadays, we do not discard the possibility of printing our own circuit board. However, we realize that by doing this, the project can suffer the consequences of our inexperience in the

subject. Once the PCB is printed and ready, then we need to mount the parts into it guiding ourselves with the printed schematics that will be finished and corrected by the time we sent the PCBs to be built. Mounting the parts can also be challenging because soldering small components like resistors and LEDs can be a hard task to do. Therefore, we are also considering on selecting a vendor that mount the parts for us because although it will be cheaper to do the mounting ourselves, we cannot forget that time is also a constraint, and it is better to have the circuit assembled by professionals who know how to efficiently put it together, than risking having to reprint the circuit boards and buy new components when the time to finish the project runs out.

6.1.2.2 Sensors

Once our circuits are ready to function, the first thing is to add all the peripherals that conform the first subsystem of our project; specifically, the sensors. Since we will not be able to build a prototype at home for discussion purposes, our PIR motion sensor and the ambient light sensors will be mounted in some kind of wooden display in order to have all of the components of the project in a small enclosure. The sensors will be connected to the main microcontroller where the inputted information will be processed and generate the desired output. The PIR motion has an embedded microcontroller; therefore, the information transmitted to the main microcontroller will be updated every time motion is detected. The ambient light sensor will also send its information to the main microcontroller every time motion is detected.

6.1.2.3 Dimmable Light System and Thermostat

Once the sensors are connected to the main hub and working, then it is time to add the output components to the circuit. Once again, the dimmable light circuit including the dimmable light bulb will be also attached to the wooden display as well as the AC thermostat. For prototyping purposes, no physical air conditioning unit is necessary because our microcontroller will be adjusting the thermostat temperature to show that it works. The dimmable lightning system will also be notified when motion has been detected and the amount of light perceived by the ambient sensor in order to be turned ON to the required settings.

6.1.3 Power Monitoring Nodes

The power monitoring nodes will be prototype in the same way as the central hub circuit. All the components will be concealed in a wooden display in order to show their capabilities as a whole. As mentioned before, the appliances that consume a high amount of power cannot be carried to with us; therefore, for prototyping purposes, smaller appliances will be considered, but we will make sure that the amount of power required to test the design is reached by such appliances.

6.1.3.1 Power Monitoring Circuit

Once the circuits are ready to be used, the designed chip will be attached to the specific appliance outlet in order to measure the current and voltage coming entering the appliance, so the power consumption of the same can be calculated. Once the power is calculated, it will be sent wirelessly to the main microcontroller in order for it to save the information to be further used in the android

application, and it also sends and update data to the LCD screen in order to display the power consumption information.

6.1.3.2 LCD Display

Once all of the previous parts of the circuit are working properly, the LCD display needs to be added to the main hub. The LCD will also be part of our outputs since the microcontroller will send the information obtained from the power monitoring nodes in order for the LCD to display an accurate and updated report on the energy consumption of the appliances. The LCD will be connected directly to the main microcontroller, so it can received the data with almost no delay or lost.

6.2 Software Prototyping

When a design is finally made, the most logical step in the building process is how to build it. Normally this can change since the system is not fully realized yet. This step helps to give the group members a sensible idea of how to build the S.H.A.P.E.R system.

The building of this system will take into considerations the research that was gathered to make the project easy to implement and to allot space to modify the system if necessary. Per engineering requirements, the initial design should be able to be modified but not too abstract that nothing can be changed.

6.2.1 Hardware

With all the software implementation established, the hardware will be constructed as follows for the system. For the lighting system, the microcontroller's program will have a main function and initialize RAM space and a watchdog timer. In the main, registers will be allocated for the LED and one for light bulb, one for the motion sensor. Since the microcontroller will use a conditional statement to test whether there is motion in the room, that conditional will include the motion sensor register and test its condition. If there is someone in the room, the value of the test condition is 1, and if there is no one in the room, the test condition is zero. Once the condition has been established, the LED will be set to on if the value of the motion sensor register is 1 to indicate there is motion in the room. The statement will take an action to equate the value of the light bulb register to 1 and initialize to the on state. For the off condition, the else statement will test the condition if false, if there is no motion in the room. The LED register will be initialized to zero meaning no motion has been detected, and run the statement to initialize the light bulb register to 0 to turn off. This statement will run in a for loop with a preset time to pass, if the timer's value has passed, the light bulb turns off.

For the ambient light sensor, this register will be initialized to zero. In the IF statement, the ambient light register set to 1 will indicate there is sunlight present or daylight. When night time occurs, the register will be set to 0. When the ambient light sensor is set to 1, the light bulb register will be set to a value to equate to the lowest brightness of the bulb. For the thermostat implementation, a register will be allocated to represent the thermostat and an LED. The LED will light up when motion has been detected. In the IF statement, when motion sensor register is 1, the thermostat register is set to 1 and code setting the temperature to a value the user specified will activate. In

the ELSE statement, a timer will also indicate a passage of time when the user is no longer in the room. After that time passes, motion sensor register is set to 0, the LED register is set to 0 and the thermostat register is set to 0, meaning return temperature to original conditions. If the user changes the thermostat settings, the thermostat register must be reset and in another IF statement, take the new value of temperature and store that into another register.

For the LCD interface, an LCD register is a special syntax in assembly in which it will take a hex decimal number representing the segments of a 7 segment number. For the power display, a register for current and another register for voltage will be used to store those values. The two values will be multiplied and stored in LCD register and will be displayed using output syntax in assembly terminology. For the Bluetooth technology, the UART terminal functions will be used. The UART functions includes an initialization phase of the registers needed to communicate with the microcontroller. It uses register R4 and R5 for input and output. The Bluetooth register will be set to zero to show that the sensor is inactive and set to 1 when it is active. Going through the conditional statement, Bluetooth register will be set to 1 when activated. Once activated, a search function will be active with another register for Bluetooth sensors in the light system and thermostat system. Their values will be set to 1 and the Bluetooth register will be set to 1. When both are set to 1, the devices show that they are paired successfully. After they are paired, the UART terminal was access the Bluetooth register and reset the value. That value will be set to a function to request the data from the power monitoring system. The power monitoring system, which will be an appliance, will also have a Bluetooth register associated with it as well. The Bluetooth register of the power monitoring system will so also be set to 1 indicating it has received the Bluetooth register request. The Bluetooth register in the microcontroller will gain two values that will be stored in the left 4 bits and right half 4 bits of the register. A function to multiply those two values for the power will then be called and the output will be sent to the LCD register for display.

6.3 Android Application Prototyping

We have prototyped screens of what our final design may look like when completed. To develop theses screens, several considerations were taken into account. In the design of applications, it is imperative to take into account what motivating factor is driving the use of the application. We designed our application using a home/personal motivating factor as our basis. This means that we took into account where the application would be utilized more heavily and what importance the different features of the app would entail.

6.3.1 Android Application Home Screen Prototype

The home screen we developed use colors to vibrantly display the choices the user will have to choose from. The home screen will be the gateway to the other sections in the application. In the Figure 36 below is the prototype for the home screen of the application.



Figure 36: Home Screen Prototype

In the creation of this prototype screen, it was very imperative for us to emphasize universal usability for this portion of the application. Universal usability means that many people would be able to use the application without having expert knowledge. Novice users would be fully able to understand what choices were available for them to make, almost intuitively.

6.3.2 Android Application Lighting Control Prototype

In the creation of the prototype for the lighting control system, we allowed inputs to be readable by the user for what percentage of power they wanted to be used for the lights. In Figure 37 below is the prototype for the lighting control screen of the application.

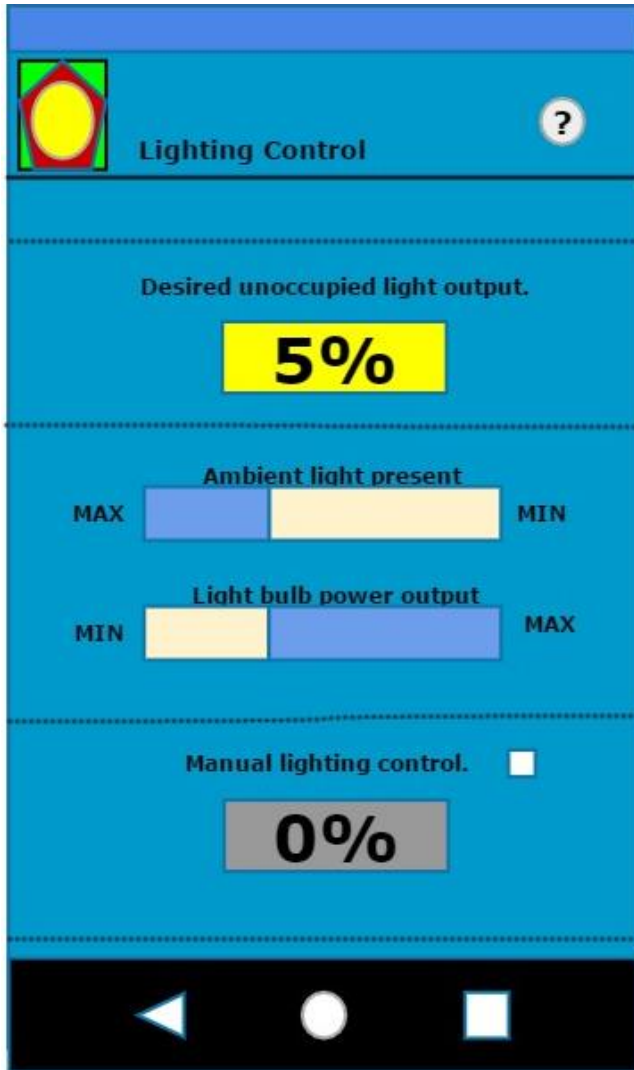

Figure 37: Lighting Control Prototype

The proper use of color is a powerful tool. Different types of colors will resonate with the user for different reasons. We use colors to optimize the intuitiveness of this application. Gray is used to indicate that a choice is not available. Like in this application screen, the input for the manual light control is grayed out unless the manual light input box is checked.

6.3.3 Android Application Cooling System Prototype

The prototyped application screen for our cooling system is simple and easy to understand. The section is titled heating and cooling because, theoretically, both are intertwined and be controlled by the same thermostat. The cooling of our environment will be sufficient to showcase the functionality of this portion of the project. In Figure 38 below is the prototype for the cooling control screen of the application.

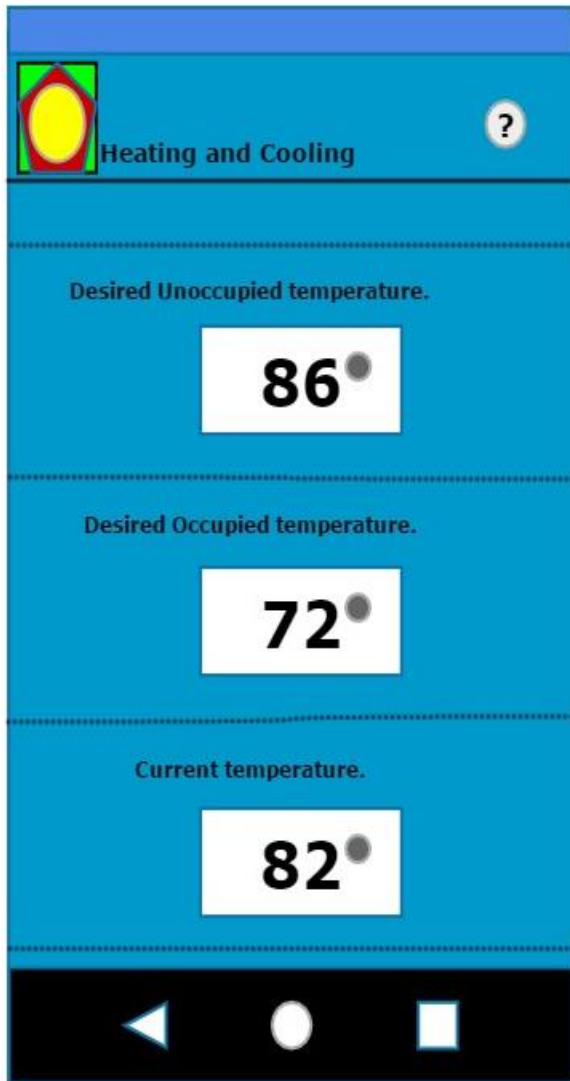

Figure 38: Cooling System Prototype

Right now, our prototype functions as a basic breakdown of what we want to implement. We hope to make our final creation more appealing and elaborate. We plan to use images as metaphorical representatives to further increase the intuitive nature of our application.

6.3.4 Android Application Power Monitoring Prototype

Our final prototyped screen is that of the power monitoring section of our application. This prototyped screen was the most cumbersome to develop, being that many more features will be added to this screen than in the others. Figure 39 below is the prototype for the power monitoring screen of the application.

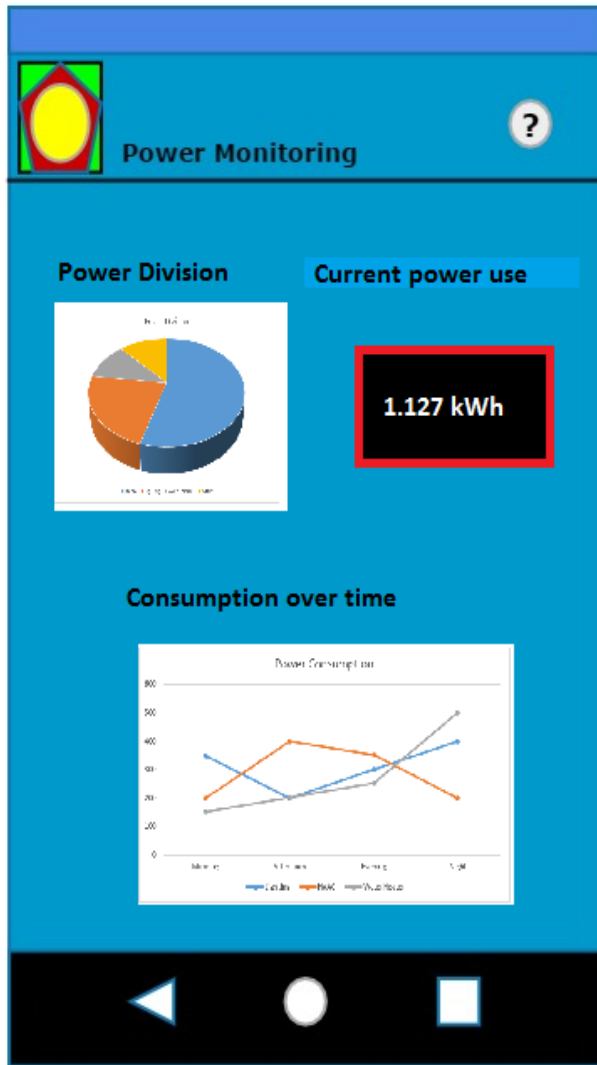

Figure 39: Power Monitoring Prototype

The power monitoring screen continually displays the amount of power being consumed by the system. The user can choose to have this information displayed to him in the form of charts and graphs. Examples of the graphs that may be displayed to the user is shown in the figure below. One of the main graphs we want to use is a line graph that shows the energy used per appliance in the household over time. This would show what time of day uses the most power from appliances and how the time of day affects the power consumption of each appliance. A better example of the line graph that may be displayed to the user is shown in Figure 40 below.

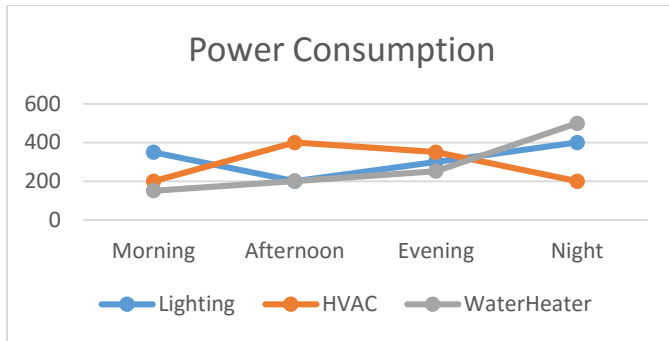

Figure 40: Example Power Displayed Line Graph

Our users will be able to see the total amount of energy being consumed by the system. They will also have the option to have the information displayed to them in the form of a pie graph. This will allow them to visually see the division of power among their appliances. Figure 41 below shows an example of a pie chart that may be generated by the system.

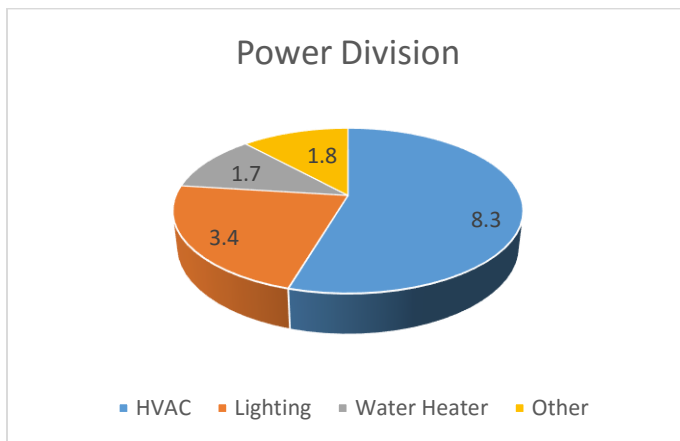

Figure 41: Example Power Displayed Pie Graph

7.0 Project Prototype Testing

The final step in the realization of the S.H.A.P.E.R. product is to test each component discussed and isolate any problems that may arise.

7.1 Hardware Testing Environment

The S.H.A.P.E.R. project will be tested in an indoor environment with windows and sufficient lighting and air conditioning units. The basic implementation is to test the lighting system. The dimmable light system will be tested first to show the user that the light can dim to certain brightness levels without constant flickering or no flickering at all. The dimming will be changed manually for demonstration purposes. Next is the occupancy sensor. As stated already, this will control when the light comes on if a person steps into the sensor's range. If the sensor is incapable of detecting movement or detecting movement of insignificant objects, then it is not efficient. If

there are more people in the room, the sensor should allow the light to stay on for longer period of time at which the user may have manually turn off the light if needed.

The ambient light sensors serve as automatic lighting controller. When outside light is detected, the dimming system comes into play. Light needs to be dimmed whereas the lighting is not brighter than the outside in the day time to conserve energy but when it is dark, the ambient lights will brighten since night time has occurred. This relieves the user of waiting light in the morning and only utilizing enough for the nighttime. Realistically, the system will be tested in a home where there is sufficient access to the already mentioned control variables

7.2 Hardware Specific

The following devices will be explained based on their physical application to the S.H.A.P.E.R. project for testing purposes. All hardware aspects must be compatible in order for proper communication to follow.

7.2.1 Microcontroller

The microcontroller will act as the central processing unit or main hub of the S.H.A.P.E.R. project. The first step in the process is that the microcontroller will be mounted on a printed circuit board and connected to the lead acid battery. The relay will go in between the lead acid battery. The microcontroller will be turned on and an LED should turn on to indicate there is power.

7.2.2 Occupancy Motion Sensor

For the testing of the motion sensor, each room will have one and near the door way in order to sense the motion of the person entering. The occupancy motion sensor will be hardwired to the microcontroller in order to communicate with the processor. This will be tested 10 times in order to test if the motion sensor picks up on the person passing. The person walking by it will pass at different speeds to make sure the motion sensor is being considered of all variables. Once a person walks by, the LED on the microcontroller needs to turn on to indicate to the user that motion has been detected. When there is no motion after a certain time period, the LED needs to turn off.

7.2.3 Ambient Light Sensor

The function of the ambient light sensor is to dim when external light is detected. The ambient light sensor will also be hardwired in order to communicate with the microcontroller and also connected to the LED bulb. This will be tested at four times of day and 1 time at night. When daylight begins, the ambient light should receive the light signal then convert into a digital signal in order for the microcontroller to process the input. At this point, if the light sensor detects a weak level of sun light then the light should increase its brightness to about 10%. The process will continue at noon when the sun is high and maximum light is available. Again the sensor detects the light coming in and the microcontroller receives the signal. The light should dim to its lowest setting since external sunlight is present. When it becomes night, the sensor will communicate to the microcontroller that there is no change in resistance because no outside light is detected.

Therefore, the microcontroller receives this and instructs the LED to output light to its brightest setting.

7.2.4 LCD Display

The LCD display will be connected to the microcontroller. When the microcontroller is turned on the LCD should display the segments of the LCD. This indicates that the LCD is initialized and data is ready to be displayed on it. This is in accordance with the thermostat since temperature will be displayed on it.

7.2.5 Power Monitor IC

The power monitoring integrated circuit will be tested on an appliance. The appliance as it is working will be communicating with the microcontroller. The microcontroller's algorithm will calculate the current and voltage being dissipated by the appliance. The LCD should display the product of the voltage and current coming through. This will be tested by using a voltage meter and check if the microcontroller is gathering the correct data.

7.3 Software Specific

The follow tests will be considering the software portions that help the ms430 to interact with the devices for testing. Problems will be isolated as necessary and documented.

7.3.1 Hardware related software

As engineers, it is always a good practice when designing a system to test the functionality and confirm that the specification requirements are valid. If they are not, the device should be modifiable if changes need to be made. In this process, the steps in completing the test will be discussed as if in a real home situation. For the design purposes already given, the testing will be conducted in a smaller system tested in a lab. The hardware aspect must comply with the devices and their standards. Since the hardware is mainly controlled by the microcontroller, the microcontroller must be verified that it is powered correctly and the program is error free for correct implementation. For the MSP430, power is verified when the power LED glows. For the assembly code, Code Composer Studio v5 will be opened and the code will have the debugger window open to look through the program in more detail in case the execution is invalid. The software piece is crucial in the devices correct implementation and execution. Any errors that occur will be documented for changes necessary. Slight errors such as circuit failure, incorrect timing of events occurring or some events not giving correct output will be taken into account.

7.3.1.1 Light System

The Light System will be testing using fluorescent bulbs which have been connected via Bluetooth 4.0 in order to be manipulated. The first part is the light turning on and off. Once the microcontroller is on, the program should compile without errors. Next when a person walks near the motion sensor, the LED on the microcontroller should light up. At this moment, the

microcontroller has sensed motion, and the motion sensor will send a signal to the microcontroller to set the state of the light bulb to on. Then, the timer is activated. When the time allotted passes, the motion sensor does not detect motion, it will send a signal to the microcontroller to turn off the LED, which will then set the state of the light bulb to off.

The same holds true for the ambient light sensor. Once there is motion, the light will turn on. At this point the ambient light sensor will be activated and be measuring any outside light. The light will change the resistance in the sensor, sending a signal to the microcontroller. Thus, the microcontroller saves the value and signals the dimmable light bulb to be set to its lowest light level. Again, if there is still motion in the room the light comes on. But if there is no external light, such as night time has occurred, the ambient light sensor's resistance will not change and will send a signal to the microcontroller that the value has not changed. Therefore, the microcontroller sends a signal to the dimmable light bulb it set its brightness level to the highest setting.

The light system will utilize three bulbs in order to test the motion sensor, ambient lighting and on off state to isolate any problems.

7.3.1.2 Thermostat

The thermostat will be an already made device for simplicity and time sake purposes. It will only communicate with the microcontroller and only give data to the microcontroller in order to isolate any problems in the communication process. The thermostat implementation is similar to the light system in that is also utilizes the motion sensor. If there is person in the room, the motion sensor sends a signal to the microcontroller. The microcontroller receives the signal and the LED should turn on. Once the LED turns on, a signal is sent from the microcontroller to activate the thermostat. The thermostat has preset conditions designated by the assembly code. The thermostat receives the value designated and displays it on the LCD screen. If someone walks about of the room, the allocated time is past for the light to be on, then a signal is sent from the microcontroller to the thermostat to set to conditions to normal settings. LED will turn off and the process continues.

7.3.1.3 Bluetooth Technology Interaction

Bluetooth functionality will be built on the same PCB board with the microcontroller and will contain a sensor. In order to test the Bluetooth technology, the programmer would utilize the terminal in order to retrieve data. When the Bluetooth is activated, the terminal receives the signal and the microcontroller acknowledges with a statement that Bluetooth is active. When the microcontroller is staring the process of pairing devices, the program will have a ready statement indicating the sensor is pairing with the nearby devices.

7.4 Android Application

It will be necessary for us to test the prototypes for our application. In this section we will explore testing the home screen, lighting control, power monitoring, and heating and cooling portion of our application. There will be testing scenarios ran to make sure that the application prototype is running and displaying properly. The test plan will be followed with to check for errors.

7.4.1 Android Application Home Screen Testing

The home screen will be a critical portion of this application. To properly test and make sure it is working properly is imperative. If the home screen has issues, accessing the other portions of the application will prove to be difficult. The main objective of the home screen will be to facilitate entering and exiting different portions of the application. There will be a need to test if the application would return from other sections successfully as well. A total of three trials will be used initially to verify everything is working at first. Our test plan for the home screen is displayed in Table 22 below.

Table 22: Home Screen Test Plan

Test case	Trial #	Explanation
Home Screen entered properly	Success / Failure	Home Screen entered explanation of observations, errors, and potential solutions.
Lighting Control entered properly	Success / Failure	Lighting Control entered explanation of observations, errors, and potential solutions.
Lighting Control returned from properly	Success / Failure	Lighting Control returned from explanation of observations, errors, and potential solutions.
Cooling Control entered properly	Success / Failure	Cooling Control entered explanation of observations, errors, and potential solutions.
Cooling Control returned from properly	Success / Failure	Cooling Control returned from explanation of observations, errors, and potential solutions.
Power Monitoring entered properly	Success / Failure	Power Monitoring entered explanation of observations, errors, and potential solutions.
Power Monitoring returned from properly	Success / Failure	Power Monitoring returned from explanation of observations, errors, and potential solutions.
Home Screen exited properly	Success / Failure	Home Screen exited explanation of observations, errors, and potential solutions.

This test plan will be repeated for a number of ten trials. Changes will then be made to the application software to address errors that were being generated from the tests.

7.4.2 Android Application Lighting Control Testing

The testing for the lighting control starts out similarly to the testing for the home screen prototype. We start out with making sure we entered the section properly and we make sure the section was exited properly at the end of the test. We also test to see if inputs were taken in properly for the desired unoccupied lighting output. We must then verify the ambient light meter increases then decrease when light is added to the system and taken away. We verify the light bulb power meter adjusts itself accordingly with the ambient light meter. We lastly verify the functionality of the manual lighting control. The list of test cases for this portion of the prototype testing is in Table 23 below.

Table 23: Lighting Control Test Plan

Test case	Trial # Result	Explanation
Lighting Control entered properly	Success / Failure	Lighting Control entered explanation of observations, errors, and potential solutions.
Unoccupied light properly displayed and adjusted	Success / Failure	Unoccupied light adjustment explanation of observations, errors, and potential solutions.
Ambient light meter increases when light added to system	Success / Failure	Ambient light increase explanation of observations, errors, and potential solutions.
Ambient light meter decreases when light removed From system	Success / Failure	Ambient light decrease explanation of observations, errors, and potential solutions.
Light bulb power increases when ambient light decreases	Success / Failure	Light bulb power increase explanation of observations, errors, and potential solutions.
Light bulb power decreases when ambient light increases	Success / Failure	Light bulb power decrease explanation of observations, errors, and potential solutions.
Manually light control adjustable when box is chosen	Success / Failure	Manual light control explanation of observations, errors, and potential solutions.
Light Control exited properly	Success / Failure	Light Control exited explanation of observations, errors, and potential solutions.

A series of twenty-five trials will be gone through to verify the reliability of this system. If errors are found, a detailed explanation of the error will be given and the error will be addressed accordingly.

7.4.3 Android Application Cooling Control Testing

The testing of the cooling control prototype will require less complexity than that of the lighting system. Whether the system was entered and exited properly will still be starting and ending points. We will primarily be testing whether the inputs from the user was properly entered and whether the current temperature is being displayed. Our test plan for the cooling control screen is displayed in Table 24 below.

Table 24: Cooling Control Test Plan

Test case	Trial # Result	Explanation
Cooling Control entered properly	Success / Failure	Cooling Control entered explanation observations.
Unoccupied temperature displayed and adjusted	Success / Failure	Unoccupied light adjustment errors and potential solutions.
Occupied temperature displayed and adjusted	Success / Failure	Unoccupied light adjustment errors and potential solutions.
Current temperature displayed and adjusted	Success / Failure	Current temperature display explanation of observations.
Cooling Control exited properly	Success / Failure	Cooling Control exited explanation of observations.

The cooling control system application tests will have a total fifteen trials. It will not be teste as vigorously as the lighting or the power monitoring application prototype screens because we feel it has the least likelihood having errors since it has the least complexity. Results from trials will be compiled and used to address changes that need to be made.

7.4.4 Android Application Power Monitoring Testing

The final testing plan for the android application prototypes will be for the power monitoring section. This testing will be the most comprehensive and have the most number of trials. A lot of computation and design to manage that computation will go into the development of this portion of the application. Therefore, extensive testing must be done to ensure verify the products are running properly. The initial test case for the power monitoring section of our application is in Table 25 below.

Table 25: Power Monitoring Primary Test Plan

Test case	Trial # Result	Explanation
Power Monitoring entered properly (current power use displayed only)	Success / Failure	Power Monitoring entered observations, errors, and potential solutions.
Current power use accurately displays total power from all devices initially	Success / Failure	Current initial total power use explanation of observations.
Current power use accurately displays total power from all devices 1 hour into monitoring	Success / Failure	Current total power use explanation of observations over one hour.
Current power use accurately displays total power from all devices 3 hours into monitoring	Success / Failure	Current total power use explanation of observations over three hours.
Power Monitoring exited properly	Success / Failure	Power Monitoring exited explanation of observations, errors, and potential solutions.

In this test we try to verify that the amount of energy use being displayed is accurate and will not falter over time. If there is an inaccuracy, a check is made to see if the inaccuracy is in the application software, hardware software or hardware components. This test is done for a total of ten trials. The lengthy time each trial takes will make having three trials enough to verify our system is flourishing in the sense that success is being made.

We will then look at the different customization our users could have for the power monitoring application prototype and run several trial tests for those. We will want to test if information is being displayed accurately. We will first test the line graph which will show the use of power for different appliances over time. The secondary test case for the power monitoring section of our application is in Table 26 below.

Table 26: Power Monitoring Secondary Test Plan

Test case	Trial # Result	Explanation
Power Monitoring entered properly	Success / Failure	Power Monitoring entered explanation of observations, errors, and potential solutions.
Current power use accurately displays total power from all devices initially	Success / Failure	Current initial total power use explanation of observations.
Line Graph displaying accurate power for chosen appliances initially	Success / Failure	Line graph initial power use display explanation of observations.
Current power use accurately displays total power from all devices 1 hour into monitoring	Success / Failure	Current total power use explanation of observations over one hour.
Line Graph displaying accurate power for chosen appliances 1 hour into monitoring	Success / Failure	Line Graph displaying accurate power for chosen appliances 1 hour into monitoring
Current power use accurately displays total power from all devices 3 hours into monitoring	Success / Failure	Current total power use explanation of observations over three hours.
Line Graph displaying accurate power for chosen appliances 3 hour into monitoring	Success / Failure	Line graph power use display explanation of observations over three hours.
Light Control exited properly	Success / Failure	Light Control exited explanation of observations, errors, and potential solutions.

In this trial we measure the progress of the line graph and the current power use display over the course of three hours. All errors are compiled and addressed to be fixed later on. We will have three trials to make sure our system is working without any potential setbacks

8.0 Administrative Content

To have a successful project, there must be an organized system in place to properly guide the team toward their goal of perfecting the smart home automated power expense regulator. This section of our report will deal with the proper management of this project. It is important to have a clear and concise structure in the implementation of the different aspects of the creation of this project. We will have great attention to detail and organization in the steps we must take in the completion of the project.

In our administrative content, we will first look at the financial costs of completing our project and what budget we will be able to afford in order to complete this project. The costs of completing a project can be vast, we want to assure that this will not limit us in the quest to make home power consumption more efficient. We will then explore the appropriate division of work in order to practically take on the many tasks we have at hand. Once the roles of each individual had been divided, milestones will be established to mark major aspects of our project being completed. We will must then mention our sponsors and their contribution to achieving the objectives we set forth. Finally, our mentor will guide us and oversee us throughout the process of the creation of our project.

8.1 Finances and Budget

In order to properly create the smart home automated power expense regulator, we will need to manage our own expenses first. The cost of creating our project can seriously hamper the progress we want to achieve. Our ideas are so novel and ambitious, that to fully implement our vision will take time and money. To properly mitigate these costs, a proper plan of financing is created. Our plan of financing will explain how we will go about paying for the project we plan implement at the end of senior design.

Our team has actively searched for sponsorship to pay and support us in the project we plan to design. There are many sponsors who look to support many senior design projects in order to brighten potential talent. Acquiring a sponsor will greatly help in easing the constraints that we may come across in the development of this project. If the sponsorship we acquire does not meet the full cost of the project, the remaining cost of the project will be divided among the four members of the group equally.

The Budget is a significant part for us to consider while researching and designing our project. Our budget will help guide us in the initial direction we plan to take our research, design, and final product. Our budget is based on the research on the project topics that we narrowed down into specific parts we will need. We plan to set aside an equal amount of money per member to acquire the material needed to complete our project. Below is Table 27, containing all the costs we plan to be necessary during the creation of the project.

Below is the representation of the parts and cost that create our budget for this project.

Table 27: Estimated Costs per Part

Part	Cost per unit (USD)	Quantity	Total Cost
Power Inverter	39.99	1	39.99
LED Dimmable Light Bulb	17.49	3	52.47
Thermostat	65.73	1	65.73
Temperature Sensor	2.99	1	2.99
Motion Sensor	10.99	4	43.96
RF Transmitter / Receiver	4.99	4	19.96
Bluetooth Module	29.99	1	29.99
Wi-Fi Module	49.99	1	49.99
Outlet	1.99	2	3.98
Relay	3.99	8	31.92
Capacitors	0.10	30	3.00
Resistors	0.05	50	2.50
Op. Amps.	0.50	10	5.00
Voltage Regulator	1.99	5	9.95
Microcontroller	0.99	5	4.95
Development Board	29.99	1	29.99
Printed Circuit Board	99.99	3	299.97
Hard Disk Drive	69.99	1	69.99
Wireless Router	49.99	1	49.99
Lead Acid Battery	119.99	1	119.99
Charge Controller	69.99	1	69.99
Total			1,006.30

The projected cost of the parts needed to build our system will not be all encompassing of the costs we may encounter. We will also encounter costs for paper, ink, and other unforeseen expenses in the future. These expenses can be in the hundreds of dollars. This will exceed our initial cost estimate of 1,006.30. Thankfully, we have been award a sponsorship from Boeing and Leidos that will pay for a great portion of what I final potential costs may be. We have also decide that we will each take up a certain amount of the costs up to a certain limit if need be. Each member will be able to contribute up to \$175.00. This will be a tough burden to bare, but we thank our sponsors at Boeing and Leidos for their generosity. Below is the Figure 42, displaying the potential division of costs.

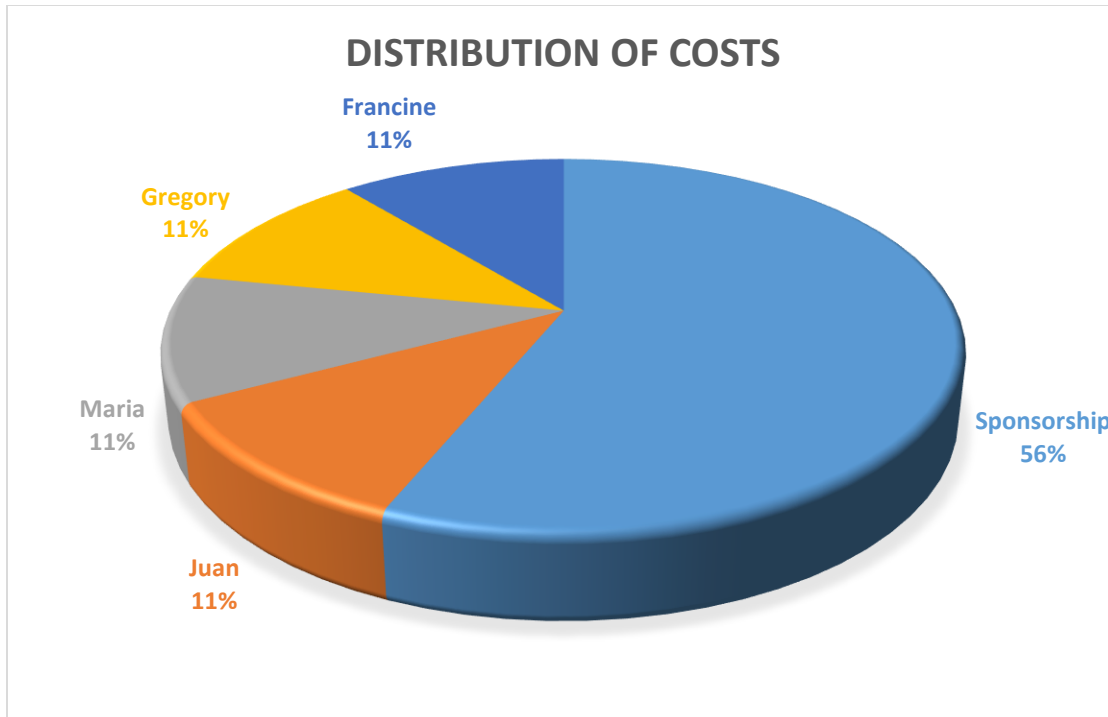

Figure 42: Cost Distribution Pie Graph

8.2 Division of Work

We consider all members of the group responsible for all parts of this project and the documentation created to support it. Every member will look over each part of the assignment, fully understand its function and importance, and contribute improvements they feel maybe necessary. Each member of the group will have basic criteria that they will need to meet in order to be working productively toward the completion of this project.

- Each member will meet with all the other members of the group at least once a week to discuss our project
- Each member of the group will dedicate either 1 hour a day to working on this project or a full eight hour work day a week to working on this project.
- Each member accepts that they may be some financial burdens and will pay their share of the divided costs.
- Each member of the group must contribute to the final documentation of the project that will be divided up evenly among the members.
- Each member will research and accumulate information on a particular subject dictated to them.
- Each member will be fully capable of constructing a functioning prototype of their designated section.
- Each member will have basic public speaking skills for presentations that will be given for the project.

8.2.1 Roles and Responsibilities

In order to get this project completed with the greatest level of efficiency, parts of the project have been divided out to have a particular member of the group focusing on it.

Juan Aleman is an Electrical Engineering Major here at the University of Central Florida. His main focus in this project will be working on the occupancy detector of our system. Juan will be the main author of the section of our assignment entitled Research related to Project Definition with the rest of us acting as editors.

Maria Alfonso is a Computer Engineering Major here at the University of Central Florida. Maria will focus on managing the dimmable light bulbs of our system. This is important because it will be one of the main showcases of our projects effectiveness. Maria is also going to be the main author of Related Standards and Realistic Design Constraints. She will be taking a look at all of the possible setbacks and better informing us of the steps we need to take. Shew will also head up the design, prototyping, and prototype testing for the many hardware components that are critical to our system.

Gregory Pierre is another Computer Engineering Major here at the University of Central. Gregory will focus on the AC thermostat and the application software. Controlling the AC thermostat will be one of the points of optimal savings. Gregory will also be the main author of the Executive Summary, Project Description, Administrative Content, and the Appendices, with the rest of us acting as editors. In addition, Gregory will be working the design, prototyping, and prototype testing of the mobile application and software relevant to the mobile applications creation.

Francine Vassell is, once again, a Computer Engineering Major here at the University of Central. Francine will focus on managing the ambient light detector of our system. This will tell us how much light is already in the room for the sake of regulating the dimmable light. Francine will also be the main author of the Project Prototype Construction and Coding sections of our assignment with the rest of the group acting as editors. In addition, Francine will be working the design, prototyping, and prototype testing of the software related to operating the hardware components of the system.

All members of the group will be in charge of the part of our project which monitors appliances and their power consumption. In addition, all members of the group will also will be responsible for reviewing, revising and editing all parts of our final documentation and final system.

8.2.2 Division of Design Process

It is important when dividing the work to take into account the engineering design process. The engineering design process consists of cultivating the project definition, diligently acquiring data from research, creating practical designs, utilizing a practical prototype, and going through extensive testing for the system. These are the five main phases we chose to work within the context of. In addition, each phase of the assignment breaks down into individual steps consisting of definition, research, design, prototyping, and testing for that individual phase. During the project definition phase our project, we will focus on defining the particulars and the scope of our project. It is within this phase that the smart home automated power expense regulator was conceived. A broad level of research is used to support the project definition choices made by the members of the team. Brainstorming sessions and prior knowledge we have obtained from previous courses

will also play a role in our project definition. The majority of our efforts during the first quarter of our project will be dedicated to our project definition. Our project definition will continue to play a small portion design process until the end of the third quarter of our project design process, where the project definition will be fully defined.

The research portion of our project design will begin to play a strong part in our method from the very beginning of the first quarter of our design process. It will take up the majority of our efforts by the second quarter of our design process. The information that we are researching will continue effect the definition of the project we have already created. The research will also effect the project design we plan to create in the future. We will begin researching more narrow topics and divide research on particular things to different group members. That research will be shared among the group members so that the information gathered could be common among us all. Research portion of our design process will be relevant until the middle of the fourth quarter of our design process. By the end of the final quarter of our design process, no more time will divided to facilitate definition or research, most efforts will be going towards final testing and presentation.

The design portion of our design process will be implemented to meet the particulars of our project definition and will be fueled by the data we have gained from the in depth research we have made on our project. Small portions of the design will be considered during the beginning of the second quarter of our assignment and it will be the majority of our focus by the end of the first semester. The design schematics we develop will develop will play a strong role in the prototyping portion of our design process. The design of our system will be affected by the start of the testing phase of our system, as the results of our tests will affect the design of the final prototype we plan to build.

The bulk of our prototyping will take place in the third quarter of our design process, in the second semester of this assignment. We estimate that more than 75 percent of our efforts will be devoted to creating the prototype of our assignment. Some efforts will still continue to go towards additional researching and design schematics if need be, however we believe that the majority of the things needed from those phases will have been obtained. While building the prototype, we developing it keeping in mind that the testing phase of our design process will be dependent on the particulars of our prototype. We will make sure the things we want to test are traceable and verifiable. Prototyping will play a role until the very end of our project design process.

The testing phase of our design process takes almost our full efforts at the end of the second semester. We will test our prototypes in the hopes of verifying our choices in our design definition. We will still consider modifying our prototype during the testing process if the results of the test will merit it. The figure depicting our groups proposed division of the engineering design process during the duration of the senior design semesters is depicted in the area chart in Figure 43 below.

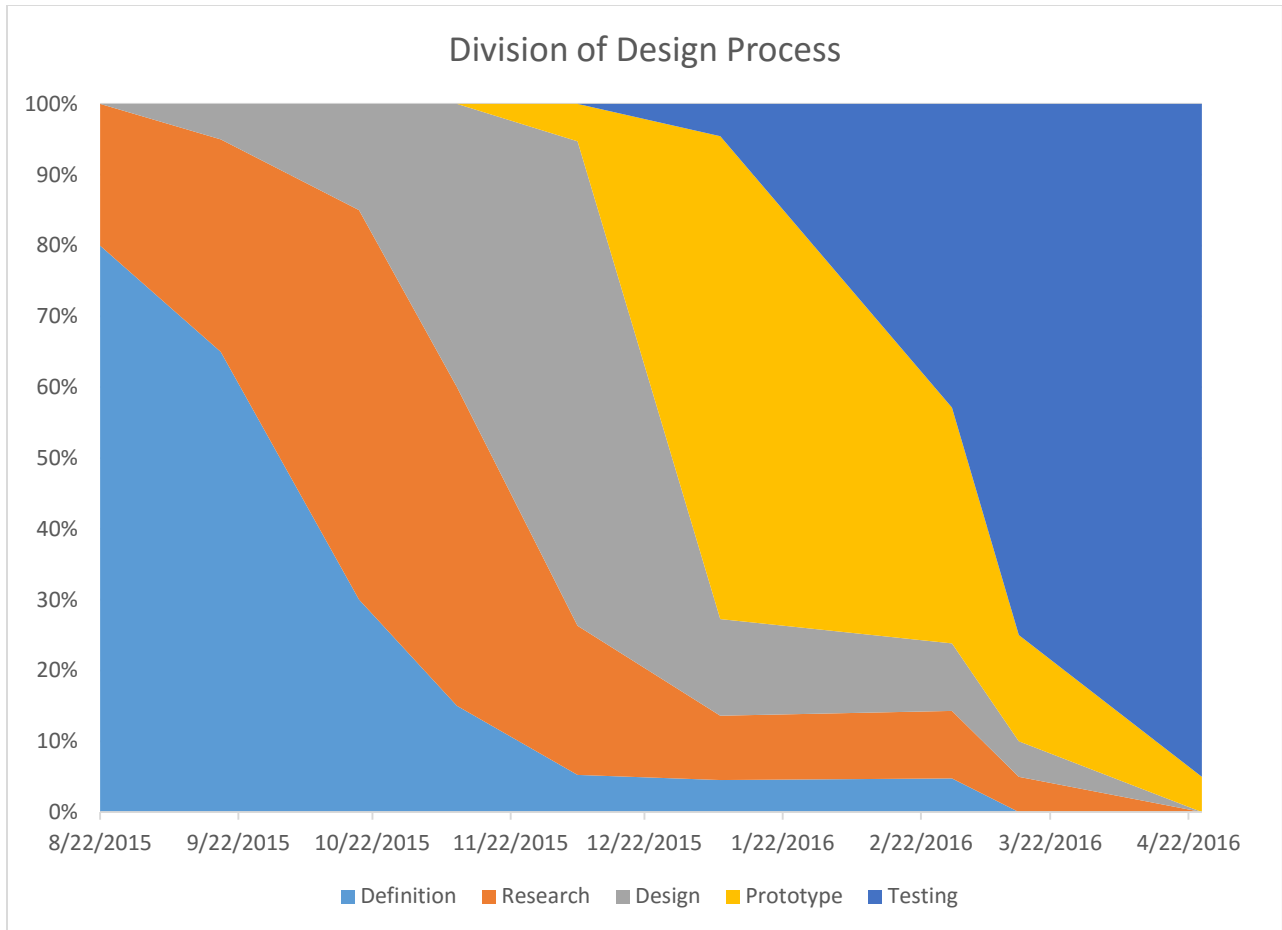

Figure 43: Design Process Area Chart

8.3 Milestones

Our group has decided upon an initial set of project milestone throughout the duration of the creation of this project. We have separated the milestones we plan to achieve into a quarterly basis. The first two quarters will be in fall 2015 and the second two quarters will commence in spring 2016.

The first quarter of project will focus on the acquisition of the information we plan to obtain. We will research many relevant information in regards to our project definition. Table 28 below shows the milestones and what is required to complete them for the first quarter of the project creation.

Table 28: First Quarter Milestones

Deliverable	Customer	Due Date/ Milestone	Technical Requirements	Steps to Complete
1) Broad research on project topics	Each team member	4 weeks by September 21st	Internet access (as will be main source of research.)	<ol style="list-style-type: none"> 1. Define the project description, objectives and goals. 2. Meet via Skype or in Person. 3. Sign Contract for accountability. 4. Discuss the specifications of the project. 5. Each team member will express his or her weakness and strength. 6. Personal Values assessment 7. Create Agenda for Next Meeting.
2) Research on specific topics, Acquire potential sponsors, Create table contents	Each team member, Potential sponsors, Faculty.	4 weeks by October 19th	High speed internet access, Microsoft word.	<ol style="list-style-type: none"> 1. Each team member will research in depth a specific component for the project according to Block Diagram. 2. Meet via Skype or in Person. 3. Discuss findings of the research. 4. Discuss project components: -compatibility -budget 5. Acquire sponsorship for project 6. Go over table of content to be turned in for review.
End of First Quarter				

The second quarter of our project will consist of us finalizing our project documentation and preparing for creating the prototype in the future portion of our project. Table 29 below shows the milestones and what is required to complete them for the second quarter of the project creation.

Table 29: Second Quarter Milestones

Deliverable	Customer	Due Date/ Milestone	Technical Requirements	Steps to Complete
3) Final research and design preparations	Team	4 weeks by November 16th	Microsoft word. Schematic design software.	<ol style="list-style-type: none"> 1. Create real life sketch using simple materials like cardboard, duct tape, etc. 2. Create functioning application prototype. 3. Schematic diagrams and method data structures. 4. Meet via Skype or in Person. 5. Create rough draft to be reviewed for feedback
4) Finalize design and get ready for prototyping Acquire potential mentors,	Potential mentors, Team	3 weeks by December 7th	Microsoft word. Instructor with soldering experience.	<ol style="list-style-type: none"> 1. Finish Project Final Documentation. 2. Order supplies. 3. Meet in Person. 4. Learn how to solder. 5. Actively search out mentors for project.
End of Second Quarter / First Semester				

The third quarter of our project will consist of us building the initial prototype and testing its functionality. Table 30 below shows the milestones and what is required to complete them for the third quarter of the project creation.

Table 30: Third Quarter Milestones

Deliverable	Customer	Due Date/ Milestone	Technical Requirements	Steps to Complete
1) Prototyping with extra features	Team	3 weeks by February 1st	Software developing tools.	<ol style="list-style-type: none"> 1. Implement extra features separately. 2. Meet via Skype or in Person. 3. Get extra supplies if needed. 4. Create Agenda for Next Meeting.
2) Prepare for first presentation /Test Prototype, Acquire faculty for review board	Each Team Member, Potential faculty review board members	1 week by February 8th	PowerPoint. Soldering experience.	<ol style="list-style-type: none"> 1. Each team member will work on their part of the project in order to deliver a good presentation. 2. Each team member will start testing their part of the project. 3. Seek out faculty members for review board.
End of Third Quarter				

The fourth quarter of this project will consist of us perfecting our project and preparing for delivering our final presentation. Table 31 below shows the milestones and what is required to complete them for the fourth quarter of the project creation.

Table 31: Fourth Quarter Milestones

Deliverable	Customer	Due Date/ Milestone	Technical Requirements	Steps to Complete
3) Build Final Project from Prototype	Each member of the team	3 weeks by February 29th	Soldering experience. Software developing tools.	<ol style="list-style-type: none"> 1. Make sure that the basic individual functions of each part of our project are met. 2. Once all of the different sections of the project have been tested, put them together to complete the project as a whole. 3. Ensure that final put together project is functioning.
4) Testing and Presenting the Final Project	Senior design review board.	8 weeks by April 25th	PowerPoint	<ol style="list-style-type: none"> 1. Test that the project runs smoothly. 2. Prepare final presentation of the project. 3. Present the Project to the faculty.
End of Fourth Quarter / Second Semester				

8.4 Sponsors

We at team S.H.A.P.E.R would like to give a special thanks to Boeing and Leidos for their support in our efforts. Their addition to our project has given us the solution to ease some of our budget and financial constraints. Without their care and generosity, none of this would be possible.

Boeing leads the world in manufacturing commercial jetliners as well as security, space and defense systems. This is a company whose reputation and reach stems worldwide. Boeing is the largest aerospace company in the world, employing over 165,000 people in the U.S and countries abroad. Boeing also has a focus on Engineering, Operations and Technology to enhance growth and productivity. They accomplish this by driving technical and functional excellence across their enterprise. The organization supports the effort of ensuring the success of development programs, reducing environmental footprint, and strives to develop a world-class technical workforce. It is a great honor for us to be receiving assistance from such a prestigious organization. Throughout the years, they have continued to shine with their professionalism, and prestige.

Leidos is a company that focuses on finding technical solutions for national security, health, and engineering problems. They continue to expand their reach with each passing year. Part of Leidos' engineering capabilities is energy management and efficiency. They help customers manage rising energy costs and implement incentive programs that help keep energy costs low. Energy management is a continually growing field. They have given 540 million dollars in incentives to

41 energy efficiency programs. Like us, Leidos also sees the great opportunity to save power and energy. By investing in bettering power consumption, they can improve the lives of billions of people around the world. They have received many awards including, the “Project Merit: Energy Efficiency (U.S. Automaker)” according to Climate Change Business Journal 2014 and “Industry Leader Award” National Safety Council 2015. What Leidos does is on a much grander scale than what we plan to implement, however we can begin to give a glimpse of things to come if we continue on this path of efficiently regulating power expense.

The help from our sponsors Boeing and Leidos has helped to give a positive push to this project and steer it towards newer heights. Us at team S.H.A.P.E.R feel proud and positively motivated to have this backing and are incredibly grateful to our sponsors.

8.5 Mentors

We each have developed a vast amount of skill in the professions we plan to acquire. That being so, there is still a lot of information that we do not know. There are those who have more knowledge and experience in the fields of the assignment we project we plan to complete. To complete this project we seek mentors who can help guide us in the aspects of this assignment that we need more answers in. FEEDER, the Foundations for Engineering Education for Distributed Energy Resources is a great resource we can use to find a mentor hat can guide us in the direction we need to go. After speaking with Matt Aberman, he will seek out the best possible mentor for us. We will need an experienced mentor to guide us through the prototyping and testing phase of our project. FEEDER plans to help UCF students for years to come, by working with them, we will also be helping groups in the future with similar questions and concerns we may have.

9.0 Project Summary and Conclusion

Home automation and energy conservation are two big events that continue to shape our world every day. The idea for this project, S.H.A.P.E.R., has been chosen by the group because of its contribution to conserving power in a world where energy is a scare resource and should be treat with care. The concern for home owners using it was also a big help in doing this project. As home users ourselves we see the functionality and applicable use of the S.H.A.P.E.R. project. As engineers, it was crucial to plan out how we could implement a smart home automation system which covers these ideals. Lighting was one of the first clues because it is a delicate resource and very prevalent among home owners and they are not always privy to how much of it they use. So research was done to choose what lighting systems would be most effective in realizing this task. The dimming and ambient lighting systems helped in solving that problem. Dimmers were a great help in reducing electrical costs for users so that a light’s max output would not have to utilize constantly. The ambient lighting system helps in considering the external light sources around the home owner such as the sun or other light sources. It helped to determine how much light was really needed based on these constraints. The air condition unit was another big item on our groups mind. Especially when external conditions can be uncomfortable and hard to bear when doing actions of great importance to a home owner. The air conditioning unit is a huge power user since it usually constantly running day and night for users. Because of this realization, the S.H.A.P.E.R. project strives to help a user to be cognizant of their ac usage. With the automated AC system controlled by the microcontroller, air conditions will be set at temperatures that are both

comfortable to the user but also taking into consideration energy conservation. The system was display on an LCD interface for the user's aesthetic portion of the system and user-friendly with touch screen capabilities. It also offers manual capabilities as well in case the user's former air conditioning preferences needed to be altered for some reason. The extra feature is the display power usage for the user's wellbeing. As stated before, many home owners are not aware of how much power their devices use and this was thought of in order to help be more aware of this fact. Electricity bills tend to run in the range of 200 dollars or more. Since we wanted this system to be easy to work with, using a wireless implementation was the best option. Wires could have also been used as well but it wouldn't look as clean after it was built. Bluetooth 4.0 was chosen since it was specifically designed for low power devices and offers some security features for home owners. This sensor is controlled by the microcontrollers Bluetooth API interface that communicates with the light, ac and power monitoring system in order to get information. Since the smart phone app technology is very popular among users because of its portability and user friendly implementation, the user also has an android os app in order to communicate with the microcontroller as well. This will aid in changing the lighting and AC also using Bluetooth technology for the user's convenience as well. Android is popular among smart phone technology. In conjunction with the app will be the java api behind its inner workings. As stated before android studio uses java as it programming language. Android studio was chosen for the integrated development environment since the android operating system is a free open source software and has tutorials for development use. Again, android is very popular application among the smart phone technology.

In Conclusion, home automation and power conservation will continue to grow as a viable and relevant technology as more power devices are designed to be more efficient for homes, cities and continue throughout the world. The S.H.A.P.E.R. project's plan, design and implementation were to realize this goal on a scalable level. The group learned a lot about how embedded systems, the microcontrollers specifically have helped in providing low power, high performance, user friendly implementation in order to design efficient systems such as low power, low current lighting systems, light elements that have a dimming feature to utilize less electricity and air conditioning temperature regulation. Other applications have also been worked on such as utilizing the elements as power sources such as wind power, solar power energy and water turbines. The methodologies used to accomplish these tasks and can very ineffective cost wise since bigger systems take more time to design and to distribute power to these systems can be challenging. But the challenge is what this project has also helped us to appreciate the many operations and experiments to provide a product that is helpful to its citizens. In the further development of the S.H.A.P.E.R. project, more features could be added that require more complex programming. One feature of the android app is to implement a voice activation program. This program will allow a user to give commands that will control the lighting, air conditioning system or request information on their systems power usage. The voice recognition technology is becoming a popular asset to many technological companies for their use in new design technology and security features. The S.H.A.P.E.R. project can also include a more complex algorithm of machine learning. The algorithm programmed in the microcontroller would be able to track a user's everyday actions concerning the lighting system and air conditioning units. Based on how much they use and at particular times of the day will be recorded and stored in an internal database for the user to access themselves and be made aware of the devices power usage and extra tips for devices that utilize a lot more energy. With the

continuing work on energy conservation, S.H.A.P.E.R. is one of the many design implementations that encourage the development of energy systems to help better the world's use of its resources.

10.0 Appendices

10.1 Copyrights

10.1.1 Permission from TI

Hello Maria,

You can find this information in Terms of Use: <http://www.ti.com/corp/docs/legal/termsfuse.shtml>

TI further grants to K-12 educational institutions, universities, and community colleges permission to download, reproduce, display, and distribute TI Services solely for use in the classroom, provided that such institutions identify TI as the source of TI Services and include the following credit line: "Courtesy of Texas Instruments." Unauthorized use of any TI Service is expressly prohibited by law, and may result in civil and criminal penalties. This grant of permission terminates if you breach any provision in these Terms of Use or Service Terms. Upon termination, you agree to destroy any materials relating to TI Services.

If you have any questions or concerns, please contact us.

Regards,

Oslyn Baker
TI Customer Support
Americas Customer Support Center
[512-434-1560](tel:512-434-1560)



<http://e2e.ti.com/>

http://www-k-ext.ti.com/sc/technical_support/plc/americas.htm

TI makes no warranties and assumes no liability for applications assistance or customer product design. You are fully responsible for all design decisions and engineering with regard to your products, including decisions relating to application of TI products. By providing technical information, TI does not intend to offer or provide engineering services or advice concerning your designs.

Please do not delete the below Thread ID when replying to this email, doing so will delay our response to your inquiry

10.1.2 Permission from Atmel

Maria,

Provided that the information you publish is accredited to Atmel Corporation and is not altered from its original format, than we provide you with our **permission**.

Thank you for choosing Atmel Corporation

Atmel Corporation
customerservice@atmel.com / www.atmel.com





Information contained in this email message may be privileged, confidential and/or protected from unauthorized disclosure. If you are not the intended recipient, any dissemination, distribution or copying is strictly prohibited. Please immediately notify the sender by reply if you received this email in error. Thank you for your cooperation.

10.1.3 Permission from PowerSwitch Tail

ST Steve <Steve@Powerswitchtail.com>
To: Juan Aleman;   | 
Wed 12/9/2015 11:53 AM



Juan,
Permission granted. And please be nice.
Regards,
: Steve

JA Juan Aleman
To: Sales@PowerSwitchTail.com;   | 
Wed 12/9/2015 11:23 AM

JA Juan Aleman
To: support@powerswitchtail.com;   | 
Wed 12/9/2015 11:17 AM

Greetings,
I'm a senior student at the University of Central Florida. I'm working on my senior design project and I would like to ask for permission to use some of the information and diagrams found in your webpage.
Thank you in advance!
Juan Aleman

10.1.4 Permission from Professor John Loomis

JL John Loomis <jloomis1@uclayton.edu>
To: Juan Aleman;   | 
Wed 12/9/2015 1:13 PM

Inbox
You forwarded this message on 12/10/2015 10:23 AM

just give me credit - in references

JL John Loomis <jloomis1@uclayton.edu>
To: Juan Aleman;   | 
Wed 12/9/2015 1:13 PM

okay

JA Juan Aleman
To: jloomis1@uclayton.edu;   | 
Wed 12/9/2015 11:31 AM

Greetings,
I'm a electrical engineering student at the University of Central Florida. I'm working on my senior design project and I would like to ask for permission to use some of the information and diagrams found in your webpage.
Thank you in advance!
Juan Aleman

10.2 References

[1] "Average Household Electricity Use around the World." Shrinkthatfootprint.com. 01 Mar. 2013. Web. 07 Dec. 2015. <<http://shrinkthatfootprint.com/average-household-electricity-consumption>>

[2] Duke Energy. "Electric Appliance Operating Cost List." Electrical Appliance Operating Cost List. Web. 25 Nov. 2015. <http://www.duke-energy.com/pdfs/appliance_opcost_list_duke_v8.06.pdf>

[3] "PowerSwitch Tail Application Instructions." *Powerswitchtail.com*. 2012. Web. 1 Dec. 2015. <http://www.powerswitchtail.com/Documents/PST_IU_Assembly_and_Application_Instructions_2012-02.pdf>.

- [4] Loomis, John. "LCD Module." *Johnloomis.org*. 29 Jan. 2009. Web. 9 Dec. 2015. <<http://www.johnloomis.org/altera/DE2/LCD.html>>.
- [5] Restrepo, Fredy. "How Does an Inverter Work?" YouTube. 15 Apr. 2014. Web. 6 Dec. 2015. <https://www.youtube.com/watch?v=IZ0bhRPpW_c>.
- [6] "Dimmer." *Wikipedia*. Wikimedia Foundation, 16 Oct. 2015. Web. 10 Dec. 2015. <<https://en.wikipedia.org/wiki/Dimmer>>.
- [7] "MSP430x5xx and MSP430x6xx Family (Rev. O)." Texas Instruments Incorporated. Web. 10 Dec. 2015. <<http://www.ti.com/lit/ug/slau208o/slau208o.pdf>>.
- [8] "MSP430F663x Mixed-Signal Microcontrollers" Texas Instruments Incorporated. Web. 10 Dec. 2015. <<http://www.ti.com/lit/ug/slau208o/slau208o.pdf>>.
- [9] "Ultra-Low Power Motion Detection using the MSP430F2013" Texas Instruments Incorporated. Web. 10 Dec. 2015. <<https://www.olimex.com/Products/MSP430/Starter/MSP430-PIR/resources/slaa283.pdf>>.
- [10] "PIR Sensor Module Memo". Web. 10 Dec. 2015. <<https://www.sparkfun.com/datasheets/Sensors/Proximity/SE-10.pdf>>.
- [11] "ZEPIR000103ZRDG." Zilog. Web. 10 Dec. 2015. <<http://www.digikey.com/product-detail/en/ZEPIR000103ZRDG/269-4910-ND/4915635>>.
- [12] "MSP430F2013 (ACTIVE)." MSP430F2013. Web. 10 Dec. 2015. <<http://www.ti.com/product/msp430f2013>>.
- [13] "CC2564 (ACTIVE)." CC2564. Web. 10 Dec. 2015. <<http://www.ti.com/product/CC2564/description>>.
- [14] "Compare Home Controllers." *HomeSeer Home Automation Systems*. Web. 1 Dec. 2015. <<http://www.homeseer.com/compare-home-controllers.html>>.
- [15] "A History of Innovation." Lutron Electronics Co., Inc. Web. 6 Dec. 2015. <http://www.lutron.com/TechnicalDocumentLibrary/Lutron%20history_innovation.pdf>
- [16] "LM344D TRIAC Dimmable Offline LED Driver." Texas Instruments Incorporated. Web. 8 Dec. 2015. <<http://www.ti.com/lit/ds/symlink/lm3445.pdf> >
- [17] "Product Index RF/IF and RFID RF Transceiver ICs." RF Transceiver ICs. Web. 10 Dec. 2015. <<http://www.digikey.com/product-search/en/rf-if-and-rfid/rf-transceiver-ics/3540293?k=cc254>>.

- [18] "2.4-GHz Bluetooth® low energy and Proprietary System-on-Chip." Texas Instruments Incorporated. Web. 10 Dec. 2015. <<http://www.ti.com/lit/ds/symlink/cc2541.pdf>>.
- [19] "High-/Low-Side Measurement, Bidirectional CURRENT." Texas Instruments Incorporated. Web. 10 Dec. 2015. <<http://www.ti.com/lit/ds/symlink/ina231.pdf>>.
- [20] "How Dimmer Switches Work." HowStuffWorks. 12 Aug. 2002. Web. 10 Dec. 2015. <<http://home.howstuffworks.com/dimmer-switch1.htm>>.
- [21] "How Bluetooth Works". Ed. Curt Franklin and Julia Layton. 3 Dec 2015 <<http://electronics.howstuffworks.com/bluetooth2.htm>>
- [22] TCP. "LED Comparison Brochurev1Sept13." Side by Side Data Comparison. Web. 18 Nov. 2015. <http://www.tcpi.com/_CE/pagecontent/Documents/LED%20Comparison%20Brochurev1Sept13.pdf>.
- [23] "What Is Color Rendering Index (CRI)?" Color Rendering Index (CRI). Web. 10 Dec. 2015. <<http://www.topbulb.com/color-rendering-index>>
- [24] "A Low Power, High Sensitivity, Light-to Digital Sensor With I2 c Interface" intersil. Web. 10 Dec. 2015. <<http://www.intersil.com/content/dam/Intersil/documents/isl2/isl29020.pdf>>.
- [25] "ISL29023." ISL29023. Web. 10 Dec. 2015. <<https://www.intersil.com/en/products/optoelectronics/ambient-light-sensors/light-to-digital-sensors/ISL29023.html>>.
- [26] "integrated digital network." Intersil. Web. 10 Dec. 2015. <<http://www.intersil.com/content/dam/Intersil/documents/isl2/isl29034.pdf>>.
- [27] "Thermostat Implementation with MSP430FR4xx User's Guide." Texas Instruments Incorporated. Web. 8 Dec. 2015. <<http://www.ti.com/lit/ug/tidu516a/tidu516a.pdf>>
- [28] "Kisae MW-1210 Modified Sine Wave Inverter, 1000W." Kisae MW-1210 Modified Sine Wave Inverter, 1000W. Web. 10 Dec. 2015. <http://www.invertersupply.com/index.php?main_page=product_info&products_id=2369&cPath=0_439&glid=Cj0KEQiA4qSzBRCq1-iLhZ6Vsc0BEiQA1qt-zv39owDvVlhRwdiGKL9mjbkgG78Cexqwv-BtCQ5VHFiaAu6m8P8HAQ>.
- [29] "Samlex SAM-800-12 Modified Sine Wave Inverter with USB." Samlex SAM-800-12 Modified Sine Wave Inverter with USB. Web. 10 Dec. 2015. <http://www.invertersupply.com/index.php?main_page=product_info&cPath=390_402&product_s_id=2097>.
- How Bluetooth Works. Ed. Curt Franklin and Julia Layton. 3 Dec 2015 <<http://electronics.howstuffworks.com/bluetooth2.htm>>
- How to Interface Bluetooth with 8051. 2015. Pantech Solutions. 3 Dec 2015. <

<https://www.pantechsolutions.net/microcontroller-boards/bluetooth-interfacing-with-8051-ps2-lab-kit>>

[30] "Samlex SAM-250-12 Modified Sine Wave Inverter with USB." Samlex SAM-250-12 Modified Sine Wave Inverter with USB. Web. 10 Dec. 2015. <http://www.invertersupply.com/index.php?main_page=product_info&cPath=390_402&products_id=2094>.

[31] "Android vs IOS." - Difference and Comparison. Web. 10 Dec. 2015. <http://www.diffen.com/difference/Android_vs_iOS>.

[32] "Android Studio Overview." Android Studio Overview. Web. 10 Dec. 2015. <<http://developer.android.com/tools/studio/index.html>>.

[33] "High or Low Side, Bi-Directional CURRENT/POWER MONITOR" Texas Instruments Incorporated. Web. 10 Dec. 2015. <<http://www.ti.com.cn/cn/lit/ds/symlink/ina220.pdf>>.

[34] "How to Interface Bluetooth" with 8051. 2015. Pantech Solutions. 3 Dec 2015. <<https://www.pantechsolutions.net/microcontroller-boards/bluetooth-interfacing-with-8051-ps2-lab-kit>>

[35] "The LED Dimming Dilemma." The LED Dimming Dilemma. N.p., n.d. Web. 10 Dec. 2015. <<http://ecmweb.com/lighting-amp-control/led-dimming-dilemma>>.

[36] "Vishay - Ambient Light Sensing." Vishay - Ambient Light Sensing. N.p., n.d. Web. 10 Dec. 2015. <<http://www.vishay.com/videos/optoelectronics/ambient-light-sensing>>.

[37] "Ambient-Light Sensors Mimic the Human Eye." Ambient-Light Sensors Mimic the Human Eye. Web. 10 Dec. 2015. <<http://www.digikey.com/en/articles/techzone/2014/feb/ambient-light-sensors-mimic-the-human-eye>>.

[38] "Ambient Light Sensors Adjust LCD Brightness to save Battery Power | EE Times." EETimes. Web. 10 Dec. 2015. <http://www.eetimes.com/document.asp?doc_id=1302779>.

[39] "Top 10 Home Automation Systems of 2016." *TopTenREVIEWS*. Web. 1 Dec. 2015. <<http://home-automation-systems-review.toptenreviews.com/>>.

[40] "Product Catalog." *Control4 Catalog*. Web. 1 Dec. 2015. <<http://www.control4.com/solutions/catalog/platform>>.

[41] "(DKC Automation) Voice-controlled Home Automation with Android (Tasker, AutoVoice, and More...)." *YouTube*. Doug Gregory. Web. 1 Dec. 2015. <<https://www.youtube.com/watch?v=RjTj0ymhbBw>>.

- [42] "Bluetooth Vs NFC Vs Wifi Direct." *Phone Guru Reviews*. MARYAM SHIEKH, 30 Nov. 2013. Web. 2 Dec. 2015. <<https://www.phonegurureviews.com/bluetooth-nfc-wifi-direct/>>.
- [43] "Bluetooth Fact or Fiction." *Bluetooth.com*. Web. 2 Dec. 2015. <<http://www.bluetooth.com/what-is-bluetooth-technology/bluetooth-fact-or-fiction>>.
- [44] Sathi, Shivani. "Pros and Cons of WiFi." *Techulator.com*. Web. 2 Dec. 2015. <<http://www.techulator.com/resources/2616-Pros-Cons-WiFi.aspx>>.
- [45] "HTG Explains: The Difference Between WEP, WPA, and WPA2 Wireless Encryption (and Why It Matters)." *HowTo Geek RSS*. Web. 2 Dec. 2015. <<http://www.howtogeek.com/167783/htg-explains-the-difference-between-wep-wpa-and-wpa2-wireless-encryption-and-why-it-matters/>>.
- [46] "Top Things to Know About Bluetooth Technology." *Bluetooth.com*. Web. 2 Dec. 2015. <<http://www.bluetooth.com/what-is-bluetooth-technology/bluetooth-technology-basics>>.
- [47] Thadani, Rahul. "Advantages and Disadvantages of Bluetooth Technology." *Buzzle.com*. 19 Mar. 2015. Web. 2 Dec. 2015. <<http://www.buzzle.com/articles/advantages-and-disadvantages-of-bluetooth-technology.html>>.
- [48] "What Is the Difference Between NFC and Bluetooth?" *HubPages.com*. Web. 2 Dec. 2015. <<http://hubpages.com/technology/nfc-vs-bluetooth>>.
- [49] "Ultrasonic Sensors." *Tech-FAQ*. 16 Nov. 2015. Web. 3 Dec. 2015. <<http://www.tech-faq.com/ultrasonic-sensors.html>>.
- [50] "Passive Infrared Sensor." *Wikipedia*. Wikimedia Foundation, 3 Dec. 2015. Web. 3 Dec. 2015. <https://en.wikipedia.org/wiki/Passive_infrared_sensor>.
- [51] Johnson, Steve. "Advantages & Disadvantages of Infrared Detectors." *EHow*. Demand Media. Web. 3 Dec. 2015. <http://www.ehow.com/facts_6151444_advantages-disadvantages-infrared-detectors.html>.
- [52] "Camera Motion Detection." *VideoNext.com*. Web. 3 Dec. 2015. [40] <http://www.videonext.com/docs/en-US/Stratus/2.7.1/html/Administration_Manual/motion.html>.
- [53] "Motion Detector." *Wikipedia*. Wikimedia Foundation, 18 Sept. 2015. Web. 3 Dec. 2015. <https://en.wikipedia.org/wiki/Motion_detector>.
- [54] "What Is Microwave Motion Detector – Benefits and Brands." *Home Security Systems Guide*. Web. 3 Dec. 2015. <<http://www.homesecuritysystems.tips/types-of-systems/what-is-microwave-motion-detector-benefits-and-brands>>.

- [55] "Ambient Light Sensors." *Clemson Vehicular Electronics Laboratory: Ambient Light Sensors*. Web. 3 Dec. 2015. <<http://www.cvel.clemson.edu/auto/sensors/ambient-light.html>>.
- [56] "Photoresistor." *Wikipedia*. Wikimedia Foundation, 5 Dec. 2015. Web. 6 Dec. 2015. <<https://en.wikipedia.org/wiki/Photoresistor>>.
- [57] "What Is a Photoresistor?" *Tech-FAQ*. 7 Feb. 2015. Web. 3 Dec. 2015. <<http://www.tech-faq.com/what-is-a-photoresistor.html>>.
- [58] "Photodiode." *Wikipedia*. Wikimedia Foundation, 26 Oct. 2015. Web. 3 Dec. 2015. <<https://en.wikipedia.org/wiki/Photodiode>>.
- [59] "Poole, Ian. Phototransistor Tutorial." *Radio-electronics.com*. Web. 6 Dec. 2015. <http://www.radio-electronics.com/info/data/semicond/phototransistor/photo_transistor.php>.
- [60] "Basics of Phototransistors - Types, Features and Applications." *ElProCus Electronic Projects for Engineering Students*. 26 Oct. 2013. Web. 6 Dec. 2015. <<http://www.elprocus.com/phototransistor-basics-and-advantages/>>.
- [61] SOFFAR, HEBA. "Macintosh Operating System Advantages and Disadvantages." *Online-sciences.com*. 31 July 2015. Web. 4 Dec. 2015.
"Mac OS." *Wikipedia*. Wikimedia Foundation, 30 Nov. 2015. Web. 4 Dec. 2015. <https://en.wikipedia.org/wiki/Mac_OS>.
- [62] "Android (operating System)." *Wikipedia*. Wikimedia Foundation, 8 Dec. 2015. Web. 8 Dec. 2015. <[https://en.wikipedia.org/wiki/Android_\(operating_system\)](https://en.wikipedia.org/wiki/Android_(operating_system))>.
- [63] "Microsoft Windows." *Wikipedia*. Wikimedia Foundation, 8 Dec. 2015. Web. 8 Dec. 2015. <https://en.wikipedia.org/wiki/Microsoft_Windows>.
- [64] "Windows Pros and Cons." *Rjsystems.nl*. 25 Apr. 2010. Web. 4 Dec. 2015. <<http://www.rjsystems.nl/en/3200.php>>.
- [65] "Main Advantages and Disadvantages of Windows Phone 8." *Windowappreviews.com*. 14 Mar. 2014. Web. 5 Dec. 2015. <<http://www.windowappreviews.com/main-advantages-and-disadvantages-of-windows-phone-8/>>.
- [66] "IEEE Standards Association." *Wikipedia*. Wikimedia Foundation, 17 Nov. 2015. Web. 5 Dec. 2015. <https://en.wikipedia.org/wiki/IEEE_Standards_Association>.
- [67] "NFC Forum: Technical Specifications." *Http://members.nfc-forum.org/*. Web. 5 Dec. 2015. <http://members.nfc-forum.org/specs/spec_list/>.
- [68] "IEEE Standards Association." *IEEE-SA*. Web. 6 Dec. 2015. <<http://standards.ieee.org/findstds/index.html>>.

[69] "Liquid-crystal Display." *Wikipedia*. Wikimedia Foundation, 6 Dec. 2015. Web. 7 Dec. 2015. <https://en.wikipedia.org/wiki/Liquid-crystal_display>.

[70] "LCD Characteristics - Advantages and Disadvantages." *Vartechsystems.com*. Web. 6 Dec. 2015. <<http://www.vartechsystems.com/pressroom/aprnewsletter2003/lcd-advantages.htm>>.

[71] "Power Inverter." *Wikipedia*. Wikimedia Foundation, 3 Dec. 2015. Web. 6 Dec. 2015. <https://en.wikipedia.org/wiki/Power_inverter>.

[72] "AC Lamp Dimmer." *Roboremo.com*. Web. 2 Dec. 2015. <<http://www.roboremo.com/ac-lamp-dimmer.html>>.

[73] "Inventor Turned Up Energy Savings by Dimming the Lights." Ed. Barbara Mulligan. Jun. 6 2013. Web. 6 Dec. 2015
<<http://news.nationalgeographic.com/news/2010/06/100604-energy-electric-light-dimmer-inventor>>